

### MULTIFUNCTIONAL KITCHEN MACHINE

### INSTRUCTION MANUAL



Dear consumer, Please read these instructions carefully before use in order to avoid damage due to incorrect use and to better understand the functions of this product. Please pay particular attention to the safety guide. If you pass the device on to a third party, these Operating Instructions must also be handed over.  
Please keep them for future references.

## IMPORTANT SAFEGUARDS

- ❑ Please read these instructions carefully before use.
- ❑ Keep present instructions for future references.
- ❑ Check that your mains voltage corresponds to that stated on the appliance.
- ❑ Only use the appliance for domestic purposes and household or similar applications such as:
  - staff kitchen areas, in shops, offices and other working environments;
  - by clients in hotels, motels and other residential type environments;
  - Environment type like :
    - Farm Houses • Bed and Breakfast.
- ❑ Only use the appliance in the way indicated in these instructions.
- ❑ Never use this unit near bathtub, shower, wash-hand basins or other containers with water.
- ❑ Never use this apparatus near water projections.
- ❑ Never use this apparatus with the wet hands.
- ❑ If, unfortunately the apparatus is wet, immediately withdraw the cord of the socket-outlet.
- ❑ Inform potential users of these instructions.
- ❑ Never leave the appliance unsupervised when in use.
- ❑ The appliance must be used only for its intended purpose. No responsibility can be taken for any possible damage caused by incorrect use or improper handling.
- ❑ This appliance shall not be used by children.
- ❑ This appliance can be used by persons with reduced physical, sensory or mental capabilities or lack of experience and knowledge if they have been given supervision or instruction concerning use of the appliance in a safe way and

if they understand the hazards involved.

- This device is not a toy, children must not play with.
- Keep the appliance and its cord out of reach of children, when it is energized, on stand by or cooling down.
- Cleaning and maintenance must not be made by children.
- In order to ensure your children's safety, please keep all packaging (plastic bags, boxes, polystyrene etc.) out of their reach.
- Caution ! Do not allow small children to play with the foil :  
**THERE IS A DANGER OF SUFFOCATION !**
- From time to time check the cord for damages. Never use the appliance if cord or appliance shows any signs of damage.
- Never immerse the appliance in water or any other liquid for any reason whatsoever.
- Never place it into the dishwasher.
- Never use the appliance near hot surfaces.
- If the supply cord is damaged, it must be replaced by the manufacturer, its service agent or similarly Competent qualified person<sup>(\*)</sup> in order to avoid a hazard.
- Disconnect the power source cable before any operation of cleaning of maintenance and accessories assembly.
- Never use the appliance outside and always place it in a dry environment.
- Never use accessories, which are not recommended by the producer. They could constitute a danger to the user and risk to damage the appliance.
- Never use any other connector than the one provided.
- Never move the appliance by pulling the cord. Make sure the cord cannot get caught in any way.
- Never wind the cord around the appliance and do not bend it
- Ensure that the power cord does not come into contact with hot parts of this unit.

- Make sure the appliance has cooled down before cleaning and storing it.
- The temperature of accessible surfaces may be very high when the appliance is operating. Never touch these parts, of apparatus, to avoid burning itself.
- Make sure the appliance never comes into contact with flammable materials, such as curtains, cloth, etc...& the power cord and plug do not come in contact with water.
- Before cleaning, always unplug the appliance from the power supply and let it cool down.
- This appliance is not intended to be operated by means of an external timer or separate remote-control system.
- Always place the unit on a flat surface. Ensure, also, not to cover the device and not to put anything on it.
- Always remove the plug from the wall socket when the appliance is not in use.
- When using an extension lead always make sure that the entire cable is unwound from the reel. Use solely CE approved extension leads. Input power must be at least 16A, 250V, 3000W.
- Incorrect operation and improper use can damage the appliance and cause injury to the user.
- This device, designed for home use, complies with standards relating to this type of product.

(\*) **Competent qualified person** : after sales department of the producer or importer or any person who is qualified, approved and competent to perform this kind of repairs.

## GENERAL INFORMATION

The symbol "OPEN BOOK" means a recommendation to read important things contained in the record.



The symbol "BIN" crossed out, abbreviation WEEE (Waste of Electrical and Electronic Equipment) means that at the end of life, it should not be discarded with household waste, but filed to the sorting of the locality. Waste recovery can help preserve our environment.



The symbol "CE" is the guarantee of compliance with harmonized European standards, voluntary, reflecting the essential requirements into technical specifications. These standards are not mandatory but are guarantees of compliance with essential requirements.



The symbol "GLASS / FORK" means that the device is compatible and can come into contact with foodstuffs.



The symbol ROHS (Restriction of use of some Hazardous Substances) on the Environmental Protection, certifies that for each of the five hazardous substances • Lead • Mercury • (hexavalent) chromium • products for protection against flames PBB and PBDE, the peak concentration is equal to or less than 0.1% of the weight of homogeneous material, and 0.01% for the 6th • cadmium.



The symbol "DOUBLE SQUARE" means a double insulated. A basic insulation and supplementary insulation. This device requires no connection to the mass of a protective conductor grounded. The materials are said : double insulation class II.

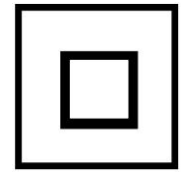

The symbol "TRIMAN" indicates that the consumer is invited to dispose the product as part of a separate collection (eg recycling bin, waste, voluntary intake point).



For more information : <http://www.quefairedemesdechets.fr>

### LOCATION OF CONTROL

- 1 - Cover Replacement of the blender
- 2 - Axis blender motor
- 3 - Fixing system of the Blender
- 4 - speed selector and Impulsion
- 5 - Unit
- 6 - Finger Training mixer / grinder
- 7 - Anti-slip Foot

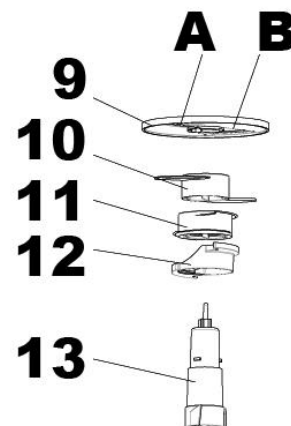
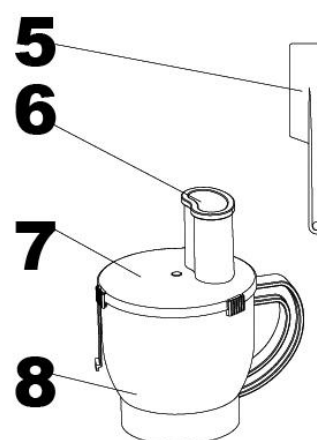
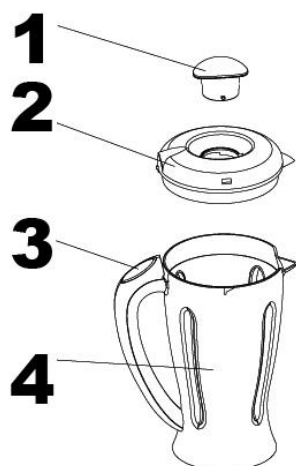
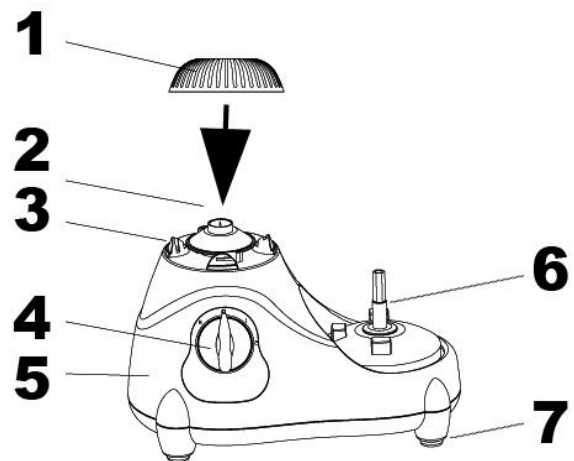

- 1 - Filling cap
- 2 - Cover the blender
- 3 - Release cover button of blender
- 4 - Bowl
- 5 - Spatula
- 6 - Push and feeding tube of mixer
- 7 - Cover of mixer / grinder

- 8 – Mixing Bowl
- 9 - A Slicer side / B Grating side of the cutting disc
- 10 - Knife with stainless steel blade
- 11 - Mixer
- 12 - Kneader
- 13 - Finger Training

## **SPECIAL WARNING FOR FOOD PROCESSOR**

### Caution !

- Always disconnect from power supply if it is left unattended and before assembling, disassembling or during cleaning.
- Switch off the appliance and disconnect from supply before changing accessories approaching parts that move in use.
- Potential injuries can occur with misuse. Care shall be taken when handling the sharp cutting blades, emptying the bowl and during cleaning, as they are extremely sharp.
- Regarding the instructions for cleaning surfaces in contact with food or oil, thanks to refer to the below paragraph "cleaning" in manual.
- Regarding the instructions for the use of accessories, operation times and speed settings, refer to the below paragraphs.
- Before placing the container, check that the device is disconnected and the gear selector is in "0" position.
- Never exceed the maximum quantities below and never pour liquids hotter than 75°C into the bowl and/or blender
- Follow the instructions given below every time you use it:
  - -Never leave the appliance unattended while it is on.
  - -Never make the appliance work while it is empty.
  - -Never touch the moving parts.
  - -Never put your fingers or utensils inside the lid opening.
  - -Never press down the ingredients into the lid opening with your hands.
  - -Do not use the appliance to work hard ingredients (e.g., frozen meat, crusts of cheese...), rubbery (e.g. candied peel...), uneatable parts of ingredients (e.g. bones, fishbone...) or crush ice.
  - -Do not remove the lid and never replace accessories without switching off the appliance and if the accessory being used has not stopped working.
  - -Do not remove the ingredients from the bowl before removing the blade

## SAFETY

This device has 4 securities  
1 on the lid of the Blender  
1 based on the Blender  
1 on the chopper lid  
1 on the chopper base

**VERY IMPORTANT: FOR SAFETY REASONS,  
THE UNIT WORKS ONLY WHEN THE BLENDER  
& THE MIXER AND ARE PERFECTLY IN PLACE  
AND SAFETY ENGAGED.**

**IF THE UNIT DOES NOT START, IT IS NOT  
NECESSARILY IN TROUBLE, ANY PARTS MAY  
NOT BE IN PLACE OR LOCKED WELL.**

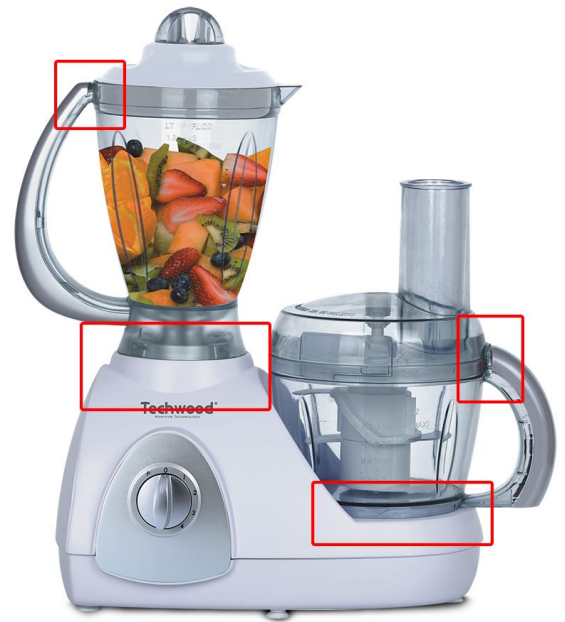

**ANY QUESTIONS REGARDING THE START OR PERFORMANCE  
OF THE FOOD PROCESSOR,  
CALL THE FOLLOWING PHONE NUMBER :**

**(33) 01 48 93 93 10 (call with no surcharge).**

## FIRST USE

Before first use, remove the unit and all accessories carefully and paying attention to the sharp accessories.

Clean with soap and water bowls and all accessories and dry thoroughly.

Clean the exterior trim and interior of the unit with a damp cloth and wipe dry.

This appliance is intended exclusively for domestic use.

1 / Place the base unit on a dry, level surface.

**DO NOT CONNECT THE UNIT AS IT IS NOT FULLY ASSEMBLED.**

2 / Place the bowl and turn clockwise to lock it in the safety position.

The triangle on the base & on the bowl must be aligned one above the other.

3 / Insert the rod into the hole in the centre of the base.

4 / Put knife, or kneader, or slicer on the drive shaft.

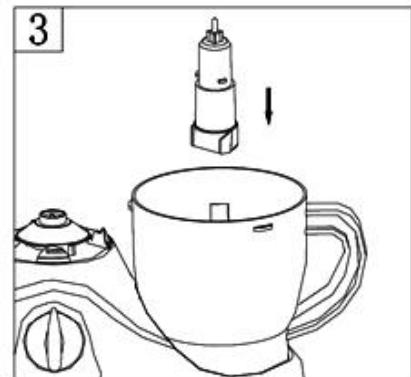
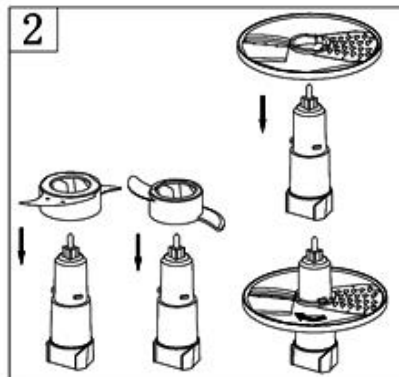
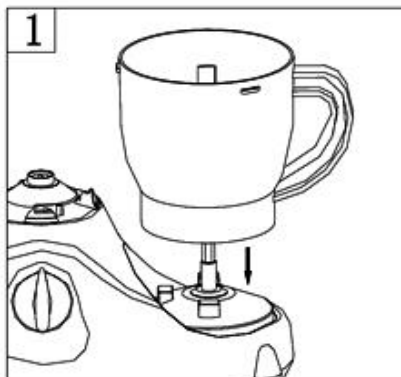

## SETTING UP THE MIXER COVER

- 1 / Place the lid on the container.
- 2 / Turn the lid clockwise to lock it to the container.

NOTES: The triangle of the base and of the bowl must be aligned one above the other.

Use the pusher to pass food through the chimney.  
Put the plunger in place during operation to avoid splashing

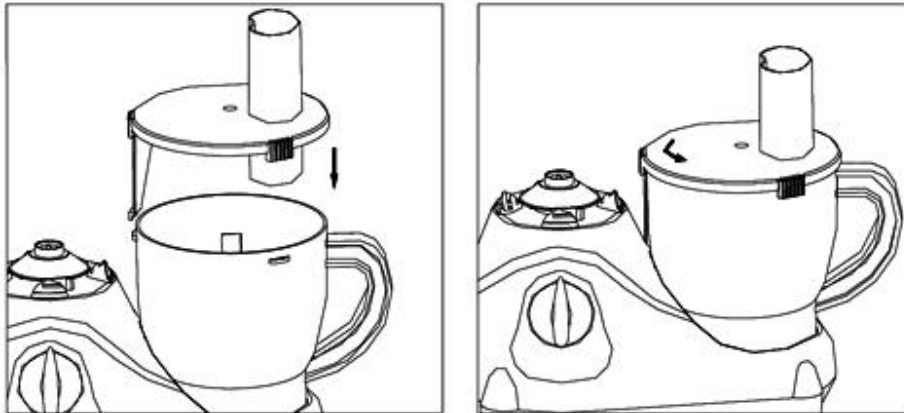

## SETTING UP THE BLENDER AND COVER OF BLENDER

### The Blender

- 1 / Take the blender by the handle and position it on the base.
- 2 / Turn clockwise to lock in safety position.

The triangle of the base and of the blender must be aligned one above the other.

Note: the knife inside the blender is not removable. Do not touch it with your fingers

THE BLADE IS VERY SHARP, USE EXTREME CAUTION WHEN HANDLING (INSTALLATION, CLEANING OUT THE WOUND AND FOOD) TO REDUCE THE RISK OF INJURY.

### The cover

- 1 / Place the lid on the blender jar. On the cover, The line must be in front of the line on the bowl.
- 2 / Turn the lid to cover the protrusion recessed into the top of the handle.

NOTE: • The opening in the lid of the blender is used to add liquid and solid foods during operation.

- Use the pusher to move food through the opening of the cover.
- It is advisable to close the blender with the cap during operation to avoid splattering out of bowl.

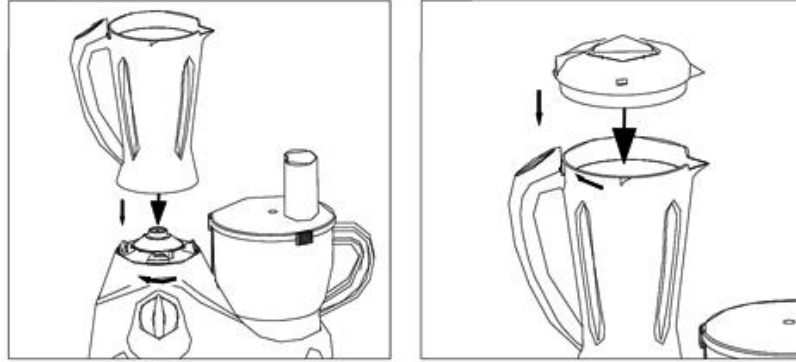

To prevent the blender running empty, when using the mixer / grinder, it is preferable to replace the blender with the lid provided for this purpose.

**IMPORTANT NOTE: THIS WITHOUT COVER OR BLENDER IN PLACE, UNIT WILL NOT START!**

1 / Place the lid on the blender site.

2 / Turn the cover clockwise to lock it in a safe position.

The triangle of the base and that of the cover must be aligned one above the other.

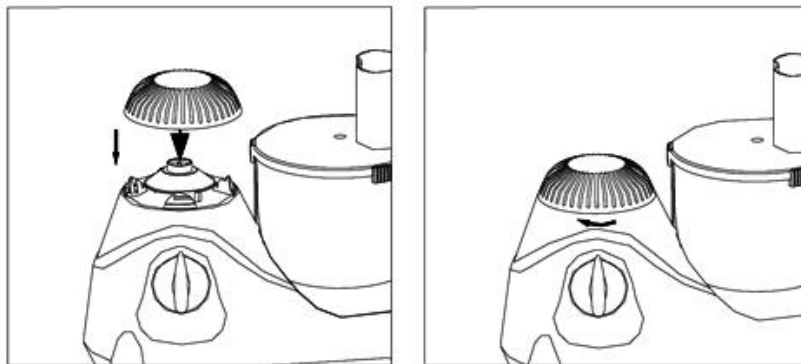

## **MIXING, CHOPPING, SLICING OR GRATING FUNCTION**

To cut, mix, cream, crumble, etc..

- Place the container on the mixing base.
- Assemble the knife on the drive shaft.
- insert the drive shaft in the container.
- Put food in the container.
- Put the lid on the container and fix it, then put the pusher in the hole lid.
- Select the desired speed.

## **A: Mixing Bowl**

### **I. Chopping Function**

- Put the protect cover onto the body tightly, as shown in Diagram 1
- Put the plastic bowl on power unit and turn the handle in clock-wise direction, as shown in Diagram2&3
- Put the blade support on the axis in the middle of the bowl, and press it to the bottom. Then fix the chopping blade to the blade support, as shown in Diagram 4&5.

Warning: The blade is sharp. Please only hold the plastic part while using.

- Put the food (egg, Meat) into the bowl, as shown in Diagram 6. Big piece food needs to be cut into small pieces. (2 cm x 2 cm x 2 cm).
- Put the cover on the bowl, and turn it until hearing the chattering sound, as shown in Diagram7.
- Fix the plug to the electric socket, Turn the knob to the required level, as shown in Diagram 8. (Levels increase the speed. PULSE is the highest level. Turn the knob to the PULSE for any intervallic operation. )
- When the chopping is finished, turn the knob to the“0”. After the blade stops, pure out the food.

### **II. Whisking Function**

Mixing function has almost the same operating steps as chopping function. Only change the chopping blade to shredding blade. It is used for mixing and whisking of food, egg & soup.

### **III. Slicing & Shredding Function**

- Put the protect cover onto the body tightly;
- Fix the slicing/shredding knife to the knife support, as shown in Diagram 9. Slicing knife makes the food into slices. Shredding knife make the food into shreds.
- Put the bowl on the power unit first, and then turn the bowl in clock-wise direction, until hearing the chattering sound. Then put the knife support on the axis in the middle of the bowl, as shown in Diagram 10.
- Put the cover on the bowl, and turn it until hearing the chattering sound. Then fix the plug to the electric socket, turn the switch to choose the level. Put into the clean food in strip from the entrance of the cover, and push the food down slowly. When the food strip is short, push them down with the measuring cup, as shown in Diagram 11&12.
- When the operation is finished, turn the knob to the“0”. After the blade stops completely, pure out the food.

## TIPS

Cut food into 3cm cubes. Arrange evenly in the container.

The device axe very quickly. SO ! operate intermittently for very short periods.

Do not let the unit run long continuously.

If foods are attached to the knife or multi-container, disconnect the device, wait for complete shutdown of the knife, remove the cover, remove food or knife attached to the inside of the container with a spatula.

### **To add food during use:**

The opening in the lid of the mixer should be used to add nutrients such as oil or juice during the operation of the apparatus.

To do this, remove the small cover in the centre of the lid and pour the food.

It may be that you have to stop the device from time to time to remove pieces of food in the bowl. In this case,

- Unplug the unit, wait a full stop, remove the cover.
- Remove food attached to the inside with a spatula, keep the spatula away from the blades of the mixer.

After use, put the switch to "0", after complete shutdown of the unit, unplug the power cord from the socket outlet.

## KNEADING AND / OR MIXING

- Place the container on the base.
- Assemble the kneader on the axis drive.
- Put the drive shaft in the container.
- Put ingredients (flour, eggs etc..) Into the container.
- Put the lid on the container and the pusher on the opening lid.
- Choose the highest speed.
- Start the unit for 1 minute.

## BLENDER JUG

### **THE BLENDER WILL WORK ONLY IF ITS COVER IS IN PLACE**

- Before use, do not plug the appliance into the socket until the blender container and multifunction are properly implemented.
- After use, disconnect the unit from the outlet before removing the blender bowl base.
- Do not fill the blender bowl with food exceeding 80 °C.
- To avoid splashing, do not put more than 1 litter of liquid food into the blender bowl.

- Never remove the lid of the blender during operation.
- The opening in the lid of the blender should be used to add foods such as oil or juice blender during operation.
- To do this, remove the cap in the centre of the lid and pour the food.

It may be that you have to stop the device from time to time to remove pieces of food in the bowl attached. In this case, disconnect the device, wait a full stop, remove the cover

Remove food attached to the inside with a spatula, keep the tip away from the blender blade.

- After use, put the switch to "0" after complete shutdown of the unit and unplug the power cord from the socket outlet.

**DO NOT OPERATE THE BLENDER FOR MORE THAN 1 MINUTE.  
COOL 1 MINUTE BEFORE RESTART THE DEVICE.**

### **CLEANING AND MAINTENANCE**

Before cleaning, Always : switch off the appliance, disconnect the apparatus and let it cool.

Clean the outside of the apparatus with a sponge or slightly wet linen.

The parts (removable) in contact with food like plate, bowl, forks, Spatula etc. can be washed in hot water with sponge and soft detergent or put in the dishwasher.

Never plunge the apparatus in water or all other liquid !

Do not use abrasive cleaners, gritting, or metal brush or another cutting object.

When you have finished cleaning make sure the parts controlled by the bowl safety system (motor unit at the point where the lip of the lid fits into place) and for models with blender jugs (jug housing on the motor unit, blender jug and lid), are not obstructed by solid waste. If necessary use a soft brush to clean eventual residuals with the appliance unplugged from the mains.

The blades cannot be sharpened. Replace them if they are not cutting properly or are worn.

### **STORAGE**

- Make sure your appliance and all its accessories are completely dry before putting them away.
- Your food processor has a space-saving storage system where all accessories can be put away tidily in the bowl.
- -Do not wrap the cord around the appliance, as this will cause damage.
- -Keep the appliance in a cool, dry place.

**CAUTION !** To avoid damages never use the appliance with accessories still inside.

## GUARANTEE

Before being delivered, all our products are subjected to a rigorous control. This apparatus is guaranteed 24 months starting from the date of purchase by the consumer.

The documents in proof of guarantee are :

- The invoice and
- The filled and stamped warrantee plate (located on side or bottom of the gift box). Without these documents in proof, no free replacement, nor no free repair, can be carried out.

During the warranty period, we deal for free, the defects of the apparatus or the accessories, rising from a defect of materials or manufacture by repair or, replacement. The services within the framework of the guarantee do not involve any extension of the warranty period and does not give right to a new guarantee ! In the event of recourse to the guarantee, bring back the complete apparatus to your retailer, in its original packing, accompanied by the proofs of purchase.

The breakage of parts out of glass or plastic is, in all the cases, not warranted.

Defects on the accessories or the wearing parts (for example: coals of engines, hooks, drive belts, remote control of replacement, teeth brushes of replacement, webs etc) as well as cleaning, maintenance or it replacement of wearing parts are not guaranteed and are thus to pay !

In the event of foreign intervention, the guarantee becomes null and void.

After flow of the warranty period, repairs can be carried out, against payment, by a specialized trade or a repair service.

## SPECIFICATIONS

Power supply	220-240V~ 50/60Hz
POWER	500W
NORM	CLASS II
Using Time	1 minute

Made in P.R.C

*The characteristics can change without preliminary preventing*

CAUTION: In order to minimize the risks of electric shock, In the event of breakdown, not to open the case but to call upon a qualified technician for repairs.

This apparatus satisfied EC directives, it was controlled according to all the European current directives, like: electromagnetic compatibility (EMC) and low tension (LVD).

This apparatus was designed and manufactured in respect of the last safety regulations and technical specifications.

**Produit importé par Sotech International  
" LE PERIPOLE " N°A107  
33, Avenue du Marechal de Lattre de Tassigny  
94120 Fontenay sous bois – France**

The symbol " CMIM " is the guarantee of compliance with optional harmonized Moroccan Standards, which reflect the essential requirements in terms of technical specifications.

These standards are not mandatory but ensuring compliance with the essential requirements.

