

MULTIFUNCTION KITCHEN MACHINE

INSTRUCTION MANUAL



Dear consumer, Please read these instructions carefully before use in order to avoid damage due to incorrect use and to better understand the functions of this product. Please pay particular attention to the safety guide.

If you pass the device on to a third party, these Operating Instructions must also be handed over.

Please keep them for future references.

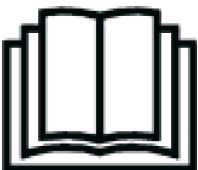

IMPORTANT SAFEGUARDS

- Please read these instructions carefully before use.
 - Keep present instructions for future references.
 - Check that your mains voltage corresponds to that stated on the appliance.
 - Only use the appliance for domestic purposes and household or similar applications such as:
 - staff kitchen areas, in shops, offices and other working environments;
 - Environment type like :
 - Farm Houses • Bed and Breakfast.
 - by clients in hotels, motels and other residential type environments;
- Only use the appliance in the way indicated in these instructions.
- Never use this unit near bathtub, shower, wash-hand basins or other containers with water.
 - Never use this apparatus near water projections.
 - Never use this apparatus with the wet hands.
 - If, unfortunately the apparatus is wet, immediately withdraw the cord of the socket-outlet.
 - Inform potential users of these instructions.
 - Never leave the appliance unsupervised when in use.
 - The appliance must be used only for its intended purpose. No responsibility can be taken for any possible damage caused by incorrect use or improper handling.
 - Children and persons with disabilities are not always aware of the danger posed by the use of appliances.
 - This appliance shall not be used by children.
 - This appliance can be used by persons with reduced physical, sensory or mental capabilities or lack of experience and knowledge if they have been given supervision or

instruction concerning use of the appliance in a safe way and if they understand the hazards involved.

- Cleaning and maintenance must not be made by children.
- Keep the appliance and its cord out of reach of children.
- This device is not a toy, do not leave children or people with disabilities to play with.
- In order to ensure your children's safety, please keep all packaging (plastic bags, boxes, polystyrene etc.) out of their reach.
- Caution ! Do not allow small children to play with the foil :
THERE IS A DANGER OF SUFFOCATION !
- From time to time check the cord for damages. Never use the appliance if cord or appliance shows any signs of damage.
- Never immerse the appliance in water or any other liquid for any reason whatsoever.
- Never place it into the dishwasher.
- Never use the appliance near hot surfaces.
- If the supply cord is damaged, it must be replaced by the manufacturer, its service agent or similarly Competent qualified person^(*) in order to avoid a hazard.
- Disconnect the power source cable before any operation of cleaning of maintenance and accessories assembly.
- Never use the appliance outside and always place it in a dry environment.
- Never use accessories, which are not recommended by the producer. They could constitute a danger to the user and risk to damage the appliance.
- Never use any other connector than the one provided.
- Never move the appliance by pulling the cord. Make sure the cord cannot get caught in any way.
- Never wind the cord around the appliance and do not bend it

- Ensure that the power cord does not come into contact with hot parts of this unit.
- Make sure the appliance has cooled down before cleaning and storing it.
- The temperature of accessible surfaces may be very high when the appliance is operating. Never touch these parts, of apparatus, to avoid burning itself.
- Make sure the appliance never comes into contact with flammable materials, such as curtains, cloth, etc...& the power cord and plug do not come in contact with water.
- Before cleaning, always unplug the appliance from the power supply and let it cool down.
- This appliance is not intended to be operated by means of an external timer or separate remote-control system.
- Always place the unit on a flat surface. Ensure, also, not to cover the device and not to put anything on it.
- Always remove the plug from the wall socket when the appliance is not in use.
- When using an extension lead always make sure that the entire cable is unwound from the reel. Use solely CE approved extension leads. Input power must be at least 16A, 250V, 3000W.
- Incorrect operation and improper use can damage the appliance and cause injury to the user.
- This device, designed for home use, complies with standards relating to this type of product.

(*) **Competent qualified person** : after sales department of the producer or importer or any person who is qualified, approved and competent to perform this kind of repairs.

USING FOR THE FIRST TIME

- Read this handbook to familiarize yourself with all the parts of your new food processor.
- Clean all the parts and accessories in contact with food before using the appliance for the first time (see paragraph “Cleaning and maintenance”).

Warning !

- Do not attempt to remove the kneading arms or whips at the start of the unit.
- Robot cannot be used to mix dry and hard foods. it may damage the used arm.
- The whip is to be used only for whites egg or liquid culinary preparations consistency. In use for a hard paste, it may be permanently damaged.
- Before removing, the unit's motor must be completely stopped, and unit unplugged.
- Always use the button to control the opening or closing of the robot arm.
- Keep hands, clothing, moved away from kneading arm during operation to reduce the risk of injury and damage.
- Operate only one accessory at a time: Blender or Mixer.
- Use a spatula to remove the food.
- If the blender does not start running, check its position. It is advisable to remove and refit it.

IMPORTANT : To use the robot as mixer, it will only work if the blender cover is securely screwed to the location of the blender.

SPECIFIC WARNINGS FOR MULTIFUNCTIONS KITCHEN MACHINES

Warning !

- Always disconnect the appliance from the supply if it is left unattended and before assembling, disassembling or cleaning.
- Switch off the appliance and disconnect from supply before changing accessories or approaching parts that move in use.
- Potential injury may occur during misuse. Care should be taken when handling, emptying the bowl and during cleaning.

- For instructions on cleaning surfaces in contact with food or oil, please refer to the "cleaning and maintenance " paragraph in the manual.

GENERAL INFORMATION

The symbol "OPEN BOOK" means a recommendation to read important things contained in the record.

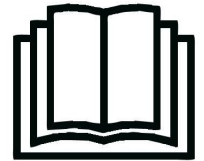

The symbol "BIN" crossed out, abbreviation WEEE (Waste of Electrical and Electronic Equipment) means that at the end of life, it should not be discarded with household waste, but filed to the sorting of the locality. Waste recovery can help preserve our environment.



The symbol "CE" is the guarantee of compliance with harmonized European standards, voluntary, reflecting the essential requirements into technical specifications. These standards are not mandatory but are guarantees of compliance with essential requirements.



The symbol ROHS (Restriction of use of some Hazardous Substances) on the Environmental Protection, certifies that for each of the five hazardous substances • Lead • Mercury • (hexavalent) chromium • products for protection against flames PBB and PBDE, the peak concentration is equal to or less than 0.1% of the weight of homogeneous material, and 0.01% for the 6th • cadmium.



The symbol "DOUBLE SQUARE" means a double insulated. A basic insulation and supplementary insulation. This device requires no connection to the mass of a protective conductor grounded. The materials are said : double insulation class II.

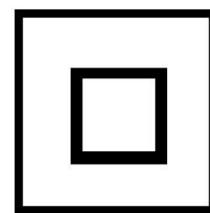

The symbol "GLASS / FORK" means that the device is compatible and can come into contact with foodstuffs.



The symbol "TRIMAN" indicates that the consumer is invited to dispose the product as part of a separate collection (eg recycling bin, waste, voluntary intake point).



For more information : <http://www.quefairedemesdechets.fr>

CLEANING AND MAINTENANCE

Always unplug from power outlet before any cleaning jobs.
Clean the outside of the apparatus with a sponge or slightly wet linen.

Do not wash it under running water and do not submerge it in water or other liquids.

The parts (removable) in contact with food like plate, bowl, forks, Spatula etc. can be washed in hot water with sponge and soft detergent or put in the dishwasher.

- For hand washing use tepid water and normal washing up detergent, being careful of the steel blade, as it is very sharp;
- Washing in the dishwasher-place accessories in the upper part and make sure the water never exceeds maximum temperature of 50°C

Do not use chemical or abrasive substances.

When you have finished cleaning make sure the parts controlled by the bowl safety system (motor unit at the point where the lip of the lid fits into place) and for models with blender jugs (jug housing on the motor unit, blender jug and lid), are not obstructed by solid waste. If necessary use a soft brush to clean eventual residuals with the appliance unplugged from the mains.

PRECAUTIONS

- Do not try to remove the accessories, hooks, beaters or whips, after starting the appliance.
- The robot cannot be used to mix dry and hard food. Doing so ! may damage the used accessory.
- The whisk should only be used for egg whites or liquid cooking preparations. When used for hard dough, the appliance can be very damaged.
- Before removing the ingredients and / or the bowl, the appliance motor must be completely stopped and the appliance unplugged.
- Always use the unlock button to control the opening or closing of the robot arm.
- Keep hands and clothing away from the device during use to reduce the risk of injury and damage.
- Use a spatula to remove the food.

TO KNOW IT'S UNIT

1. Tray for food to chop
2. Graduated glass blender
3. Lid with filler cap
4. Blender handle
5. High "lifting" part of the robot
6. Robot unlock button
7. Speed selector
8. Non-slip feet
9. Stainless steel bowl, Capacity 5L
10. Splash cover
11. Meat grinder



FIRST USE

Before first use, remove the device and all accessories and being careful with sharp accessories.

- Clean the apparatus according to the instructions in "Cleaning and maintenance" paragraph.
- Place the machine on a suitable flat, stable surface.



ANY QUESTIONS REGARDING THE START OR PERFORMANCE OF THE FOOD PROCESSOR, CALL THE FOLLOWING PHONE NUMBER : 01 48 93 93 10 (call with no surcharge).

SAFETY

Before placing the bowl, check that the device is disconnected and the gear selector is in "0" position.

VERY IMPORTANT: THE APPLIANCE OPERATES ONLY WHEN THE BLENDER or THE KNEADING MACHINE or THE MEAT GRINDER IS PERFECTLY IN PLACE. SAFETIES ACTIVATED. IF THE UNIT DOES NOT START, IT IS NOT NECESSARILY IN TROUBLE, ANY PARTS MAY NOT BE IN PLACE OR LOCKED WELL.

SAFETY COVERS

Depending on the function used:

This part (1) is only a décor on this model.

To use as Kneading machine

Fit the safety cover (1)
in the location for the meat grinder.
(At the front of the device).

Fit the safety cover (2)
in the space provided for the Blender.
(On the top of the device).

To use as Blender

Fit the safety cover (1)
in the location for the meat grinder.
(At the front of the device).

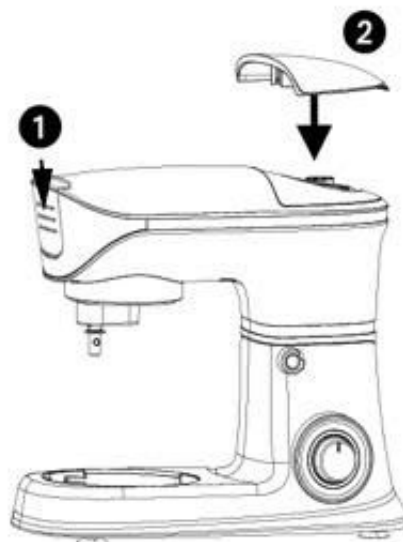

Remove the safety cover (2) to put Blender in place.

Do not put a bowl in place. (3)

Note : Do not insert a whisk or beater while using the blender.
When using the Blender, the mixer shaft will run normal.

To use as Meat grinder

Remove the safety cover (1) by pulling it upwards.
(At the front of the device).

Fit the safety cover of the Blender (2).

Do not put a bowl in place (3).
Install the chopper on the appliance.
(see below !)



Assembly of the meat grinder

Mount the silicone ring (1) on the worm screw (2) and insert the assembly into the chopper (3).

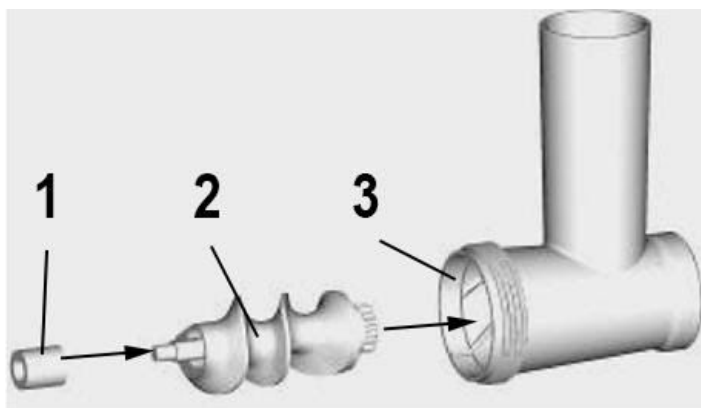

Mount the knife blade (1) on the axis of the worm screw (2).

Note: The cutting edge of the blade should point forward. (to the hash disk.)

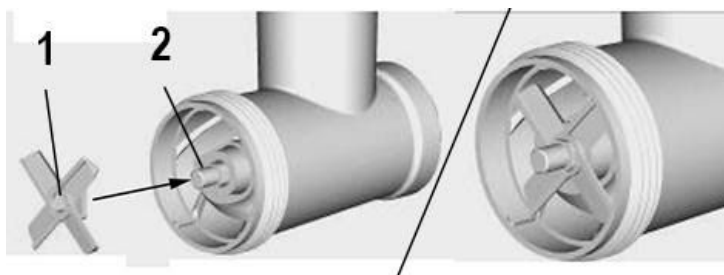

Install one of the chopping discs (1) in front of the knife blade (2).

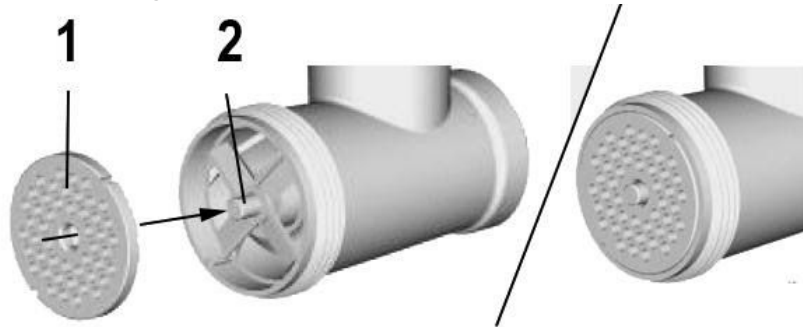

Notes : match grid with the chopper.

the notch on the lug on the

It is possible to choose; Fine, medium or large grid.

Place the ring nut (1) in front of the chopping disc on the meat grinder and turn clockwise (2) to tighten it.

Note : The nut must hold the chopping disc securely in place. But don't over-tighten it.

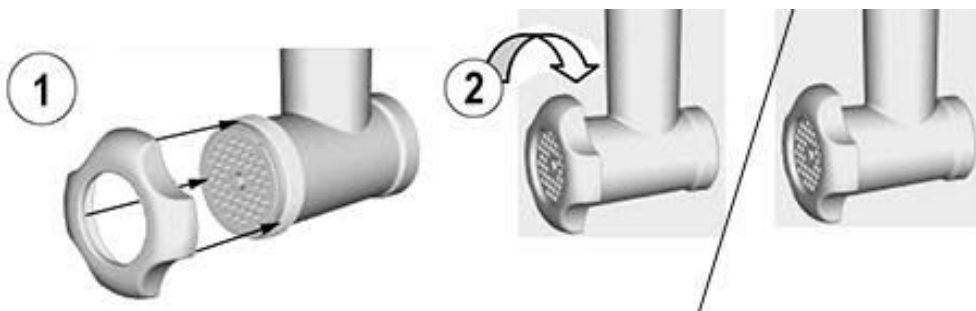

Insert the chopper on the front of the appliance. To do that :

Tilt the chopper tube 25 ° to the right and enter the chopper shaft into its place. (A)

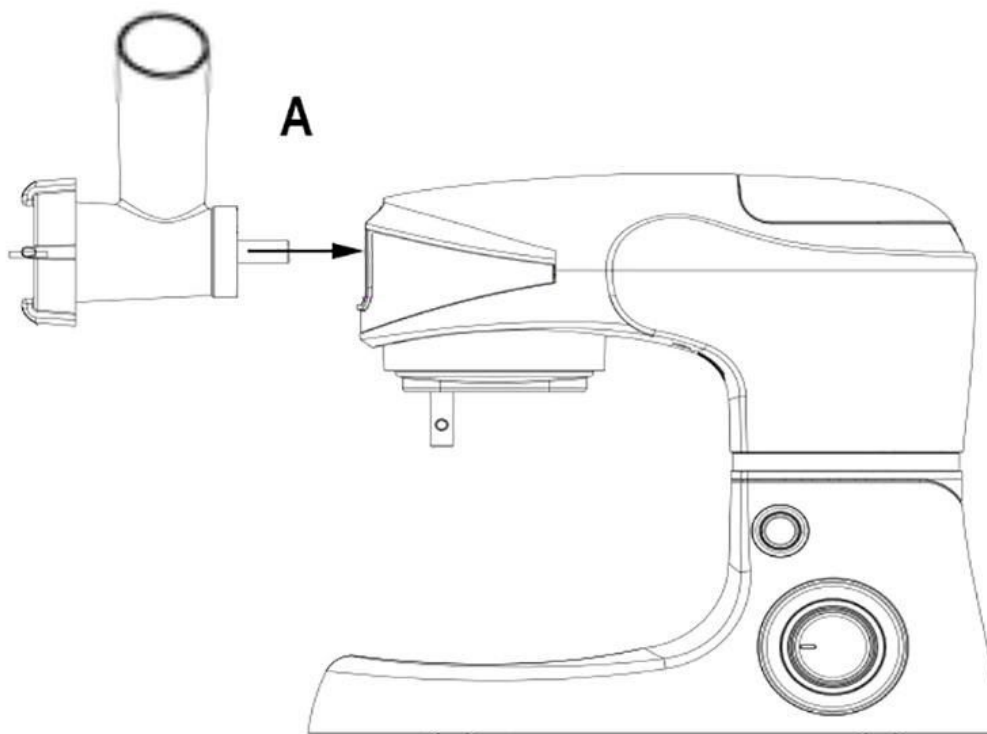

When the mincer is inserted in the appliance, the logo (triangle) located on the mincer must be opposite the logo (triangle + open padlock) of the appliance (1).

Turn the chopper to the left (counter clockwise) (1) so that the logo (triangle) of the chopper comes in front of the logo (triangle + closed padlock) of the device (2).

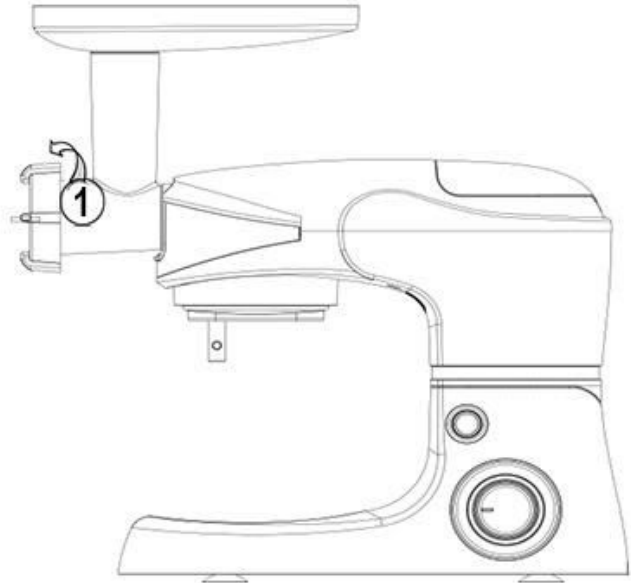
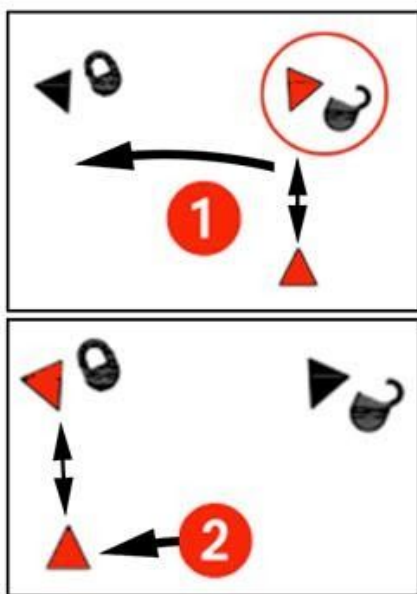

The chopper is then in place and ready to receive the food to chop.

USE

- Unroll the power cord completely.
- Check that the tension in force in the country where you are, corresponds to that indicated on the apparatus.
- Connect the apparatus in a correct socket-outlet, (and connected to the ground if the unit is Class I), to avoid any danger.
- Disconnect the power source cable before any operation of cleaning of maintenance and accessories assembly.
- Never modify the appliance in anyway.

- Do not try to remove the kneading arm or the whisk when switching on the appliance.
- The food processor cannot be used to mix hard and dry food at the risk of damaging the arm used.
- The whisk is to be used only for eggs in snow or liquid cooking preparations. In use for a hard dough, it may be permanently damaged;
- Before each dismantling, the device's engine must be completely stopped and the device unplugged.
- Always use the button to control the opening or closing of the robot arm.
- Keep hands and clothing out of the reach of the kneading arm during operation to reduce the risk of injury and not to damage the machine.
- Operate only one accessory at a time: Blender, Kneader or Chopper.
- Use a spatula to remove food.
- Always put the cover on for blender operation and check that the cover is in place before operating the appliance.
- If the blender does not start up, check its positioning. It is advisable to remove it and put it back in place.

IMPORTANT: to use the appliance without the blender and or the meat grinder, it will only work if the safety covers replacing the Blender & the grinder are correctly positioned at their place.

THIS APPLIANCE IS INTENDED FOR HOUSEHOLD USE ONLY

Never exceed the maximum quantities below.

Never pour liquids hotter than 75°C into the bowl and/or blender

Follow the instructions given below, every time you use it :

- Never leave the appliance unattended while it is on.
- Never make the appliance work while it is empty.
- Never touch the moving parts.
- Never put your fingers or utensils inside the lid opening.
- Never press down the ingredients into the lid opening with your hands.
- Do not use the appliance to work hard ingredients (frozen meat, crusts of cheese...), rubbery (candied peel...), and uneatable parts of ingredients (bones, fishbone...).
- Do not remove the lid and never replace accessories without switching off the appliance and if the accessory being used has not stopped working.
- Do not remove the ingredients from the bowl before removing the blade

KNEADING

Fit the safety covers of the blender (see paragraph above).



Press the open / close button and raise the upper part of the robot.



Install the bowl lid on the spindle.
 Turn clockwise to secure.
 Install the bowl on its base (2).
 Turn clockwise to secure.

Install the accessory (whip or hook or beater) on the axis of the robot by engaging it.
 Turn counter-clockwise (left) to lock.
 Press the open button & lower the top of the robot.
Check that it is properly secured before turning it on.

Pour the ingredients into the bowl. (Or pour them before attaching the bowl).

Connect the unit and turn the speed selector to the desired speed.

INGREDIENTS LIST

Material	Max. quantity	Remark	Tool
Stiff yeast dough	1500g	Flour and water at a ratio of 5:3, Pre-treatment of dough: From speed 1 for 180second; Operation period: Speed 2 for 10second	
Soft yeast dough	2000g	Flour and water at a ratio of 1.1:1 Pre-treatment of dough: From speed 1 for 90 second; Operation period: Speed 2 for 10 second	
			

Eggs	24 eggs	Switch on speed 8 to speed 10, whip the egg whites without stopping for 3-4min	
Whipped cream	300ml fresh cream	From speed 1 to 4 for about 5minutes	
Shakes, cocktails or other liquids	1 L	Beating eggs into creamed mixtures From speed 1 for about 4minutes	

Caution! These tips are purely indicative.
Refer to personal experience for even better results.



Beater : For making cakes, biscuits, pastry, icing, fillings, mashed potato.



Whisk : For eggs, cream, batters, fatless sponges, meringues, cheesecakes mousSES, souffles.
Don't use the whisk for heavy mixtures you could damage it.



Dough hook : For yeast mixtures.

BLENDER

Do not insert whisk or beater or remove it (if necessary) from the kneader shaft while using the blender.

Add the ingredients to mix in the blender.

Put the lid on. (With the cup in the centre of the lid).

Place the blender on its location on the robot (1).

Turn the blender clockwise to lock it (2).

Note : The arrows should be positioned as in the below drawing.

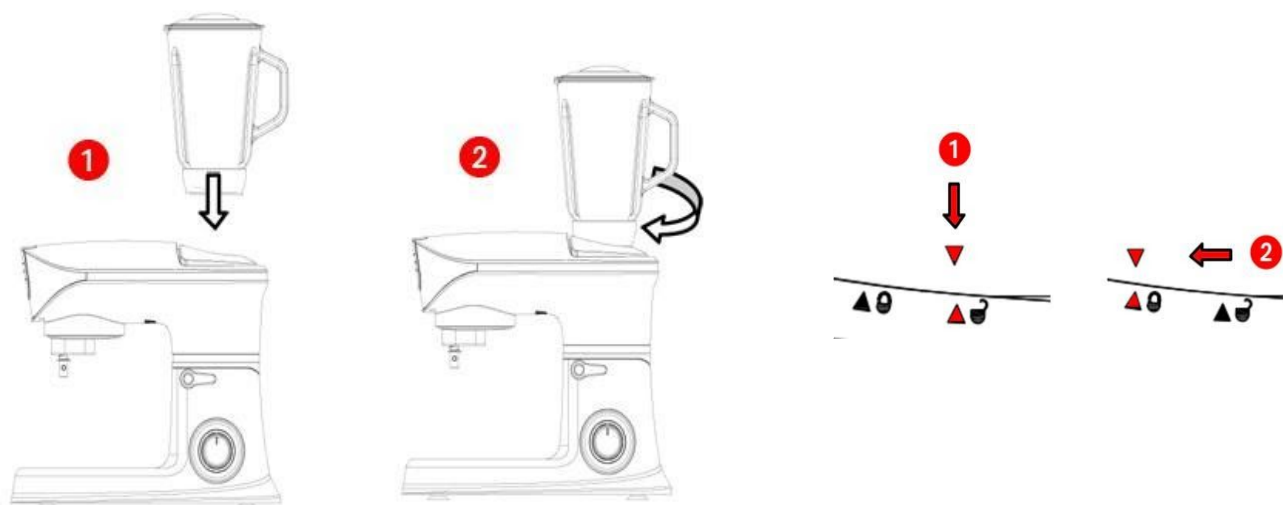

Connect the unit and turn the speed selector to the desired speed.

Note : The removable cap of the lid allows addition of ingredients during the mixing process, with safety.

RECIPE SUGGESTION

To mix or knead dough:

Suggestion flour and water at a ratio of 5 / 3.

From speed 1 for mix 10 s and speed 2 for mix 10 second, afterwards, speed 3 for about 3 minutes.

When filling the mixing bowl, please ensure that the maximum quality is not exceeded.

Maximum quantity of flour is 1500g .

The dough beater or mixer beater should be used.

Whipping egg whites or cream:

- Switch on speed 4 to speed 6, whip the egg whites without stopping for about 5 minutes, according to the size of the eggs, until stiff.
- Maximum quantity 24 eggs.
- For whipped cream, whip 250ml fresh cream at speed 4 to 6 for about 5 minutes.
- When filling the mixing bowl with fresh milk, cream or other ingredients, please ensure that the maximum quality is not exceeded.
- The egg beater should be used.

Mixing shakes, cocktails or other liquids:

1. Mix the ingredients according to the available recipe, from speed 1 to 6 for about 5 minutes.
2. Do not exceed the maximum quantity for the agitator kettle.
3. The mixer beater should be used.

Maximum operating time 10 minutes.

- Trick**
- 1 Switch off and scrape the bowl with the spatula frequently.
 - 2 Eggs at room temperature are best for whisking.
 - 3 Before whisking egg make sure there's no grease or egg yolk on the whisk or bowl.
 - 4 Use cold ingredients for pastry unless your recipe says otherwise.

Point for bread making

- 1 Never exceed the maximum capacity, otherwise you will overload the appliance.
- 2 If you hear the appliance labouring, switch off, remove half the dough and do each half separately.
- 3 The ingredients mix best if you put the liquid in first.

Mixable fruit quantity table

Material	MAX. QUANTITY	MAXIMUM TIMES (s)
apple	250g	30s
orange	300g	30s
grape	250g	30s
strawberry	250g	30s

STORAGE

- Ensure the unit is completely cool and dry.
- Do not wrap the cord around the appliance, as this will cause damage.
- Keep the appliance in a cool, dry place.

Your food processor has a space-saving storage system where all accessories can be put away tidily in the bowl.

CAUTION !

To avoid damages never use the appliance with accessories still inside the bowl.

GUARANTEE

Before being delivered, all our products are subjected to a rigorous control. This apparatus is guaranteed 24 months starting from the date of purchase by the consumer.

The documents in proof of guarantee are :

- The invoice and
- The filled and stamped warrantee plate (located on side or bottom of the gift box). Without these documents in proof, no free replacement, nor no free repair, can be carried out.

During the warranty period, we deal for free, the defects of the apparatus or the accessories, rising from a defect of materials or manufacture by repair or, replacement. The services within the framework of the guarantee do not involve any extension of the warranty period and does not give right to a new guarantee ! In the event of recourse to the guarantee, bring back the complete apparatus to your retailer, in its original packing, accompanied by the proofs of purchase.

The breakage of parts out of glass or plastic is, in all the cases, not warranted. Defects on the accessories or the wearing parts (for example: coals of engines, hooks, drive belts, remote control of replacement, teeth brushes of replacement,

webs etc) as well as cleaning, maintenance or it replacement of wearing parts are not guaranteed and are thus to pay !

In the event of foreign intervention, the guarantee becomes null and void.

After flow of the warranty period, repairs can be carried out, against payment, by a specialized trade or a repair service.

SPECIFICATIONS

Power supply	220-240V~ 50/60Hz
Power	Mixeur 1000W, Blender 1000W, Mincer 300W
Norm	Class II

Made in PRC

The characteristics can change without prior notice.

CAUTION: In order to minimize the risks of electric shock, In the event of breakdown, not to open the case but to call upon a qualified technician for repairs.

This device complies with EC directives, it was controlled according to all current European directives, applicable such as: electromagnetic compatibility (EMC) and low voltage (LVD).

This device has been designed and manufactured in compliance with the latest regulations and technical requirements for safety.

**Imported by Sotech International
" LE PERIPOLE " N°A-107
33, Avenue du Marechal de Lattre de Tassigny
94120 Fontenay sous-bois - France**