

### CREPE MAKER ( 2 IN 1 )

### Instruction manual



Dear consumer, Please read these instructions carefully before use in order to avoid damage due to incorrect use and to better understand the functions of this product. Please pay particular attention to the safety guide.

If you pass the device on to a third party, these Operating Instructions must also be handed over.

Please keep them for future references.

## IMPORTANT SAFEGUARDS

- Please read these instructions carefully before use.
- Keep present instructions for future references.
- Check that your mains voltage corresponds to that stated on the appliance.
- Only use the appliance for domestic purposes and household or similar applications such as:
  - staff kitchen areas, in shops, offices and other working environments;
  - By clients in hotels, motels and other residential type environments;
  - Environment type like :
    - Farm Houses • Bed and Breakfast.
- Only use the appliance in the way indicated in these instructions.
- Never use this unit near bathtub, shower, wash-hand basins or other containers with water.
- Never use this apparatus near water projections.
- Never use this apparatus with the wet hands.
- If, unfortunately the apparatus is wet, immediately withdraw the cord of the socket-outlet.
- Inform potential users of these instructions.
- Never leave the appliance unsupervised when in use.
- The appliance must be used only for its intended purpose. No responsibility can be taken for any possible damage caused by incorrect use or improper handling.
- Children and persons with disabilities are not always aware of the danger posed by the use of appliances.
- This appliance can be used by children aged from 8 years and above and persons with reduced physical, sensory or mental capabilities or lack of experience and knowledge if they have been given supervision or instruction concerning

use of the appliance in a safe way and understand the hazards involved. Children shall not play with the appliance. Cleaning and user maintenance shall not be made by children unless they are older than 8 and supervised.

- Keep the appliance and its cord out of reach of children less than 8 years.
- Regarding the instructions for cleaning surfaces in contact with food, thanks to refer to the below paragraph of the manual.
- This device is not a toy, do not leave small children or people with disabilities to play with.
- In order to ensure your children's safety, please keep all packaging (plastic bags, boxes, polystyrene etc.) out of their reach.
- Caution ! Do not allow small children to play with the foil :  
**THERE IS A DANGER OF SUFFOCATION !**
- From time to time check the cord for damages. Never use the appliance if cord or appliance shows any signs of damage.
- Never immerse the appliance in water or any other liquid for any reason whatsoever.
- Never place it into the dishwasher.
- Never use the appliance near hot surfaces.
- Do not operate the appliance with a damaged cord or plug, or after the appliance has been damaged in any manner. If the supply cord or appliance is damaged, it must be replaced by the manufacturer or its service agent or a similarly qualified person\* in order to avoid a hazard.
- Disconnect the power source cable before any operation of cleaning of maintenance and accessories assembly.
- Never use the appliance outside and always place it in a dry environment.

- ❑ Never use accessories, which are not recommended by the producer. They could constitute a danger to the user and risk to damage the appliance.
- ❑ Never use any other connector than the one provided.
- ❑ Never move the appliance by pulling the cord. Make sure the cord cannot get caught in any way.
- ❑ Never wind the cord around the appliance and do not bend it
- ❑ Ensure that the power cord does not come into contact with hot parts of this unit.
- ❑ Make sure the appliance has cooled down before cleaning and storing it.
- ❑ The temperature of accessible surfaces may be very high when the appliance is operating. Never touch these parts, of apparatus, to avoid burning itself.
- ❑ Make sure the appliance never comes into contact with flammable materials, such as curtains, cloth, etc...& the power cord and plug do not come in contact with water.
- ❑ Before cleaning, always unplug the appliance from the power supply and let it cool down.
- ❑ This appliance is not intended to be operated by means of an external timer or separate remote-control system.
- ❑ Always place the unit on a flat surface. Ensure, also, not to cover the device and not to put anything on it.
- ❑ Always remove the plug from the wall socket when the appliance is not in use.
- ❑ When using an extension lead always make sure that the entire cable is unwound from the reel. Use solely CE approved extension leads. Input power must be at least 16A, 250V, 3000W.
- ❑ Incorrect operation and improper use can damage the appliance and cause injury to the user.
- ❑ This device, designed for home use, complies with standards relating to this type of product.

- The appliance must be used and rested on a table or flat & stable surface.
- The item must not be left unattended when it is connected to main supply.
- The item is not to be used, if it has been dropped or if there are visible signs of damage or if it is leaking.
- This appliance is only intended for household use.
- Regarding the instructions for cleaning, thanks to refer to the below paragraph of the manual.

(\*)**Qualified person** : after sales department of the producer or importer or any person who is qualified, approved and competent to perform this kind of repairs.

## GENERAL INFORMATION

The symbol "OPEN BOOK" means a recommendation to read important things contained in the record.

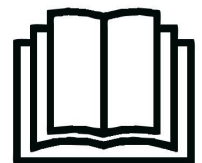

The symbol "BIN" crossed out, abbreviation WEEE (Waste of Electrical and Electronic Equipment) means that at the end of life, it should not be discarded with household waste, but filed to the sorting of the locality. Waste recovery can help preserve our environment.



The symbol "CE" is the guarantee of compliance with harmonized European standards, voluntary, reflecting the essential requirements into technical specifications. These standards are not mandatory but are guarantees of compliance with essential requirements.



The symbol "GLASS / FORK" means that the device is compatible and can come into contact with foodstuffs.

The symbol ROHS (Restriction of use of some Hazardous Substances) on the Environmental Protection, certifies that for each of the five hazardous substances • Lead • Mercury • (hexavalent) chromium • products for protection against flames PBB and PBDE, the peak concentration is equal to or less than 0.1% of the weight of homogeneous material, and 0.01% for the 6th • cadmium.



The symbol "HOT WALL" warns the user that the walls of the unit can become very hot, and to take precautions as required.

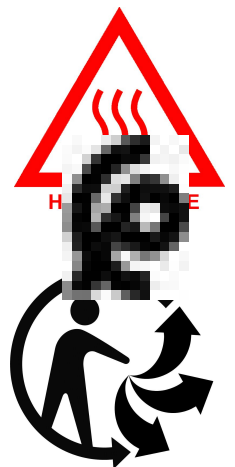

The symbol "TRIMAN" indicates that the consumer is invited to dispose the product as part of a separate collection (eg recycling bin, waste, voluntary intake point).

For more information : <http://www.quefairedemesdechets.fr>

The symbol "CMIM marking" is the guarantee of compliance with the harmonized Moroccan Standards, optional, which translate the essential requirements into technical specifications. These standards are not mandatory but guarantee compliance with the essential requirements.

### **BEFORE FIRST USE**

Before first use, remove the unit and all accessories carefully and paying attention to the sharp accessories.

Clean with soap and water, bowls and all accessories. Rinse and dry thoroughly.

Clean the outside and inside of the machine cabinet with a damp cloth and wipe dry.

### Description of the appliance

1. Power indication light
2. Temperature indication light
3. Non-stick cooking plate
4. Non-stick mini crepes plate
5. On/off switch
6. Base cover
7. Wooden stick

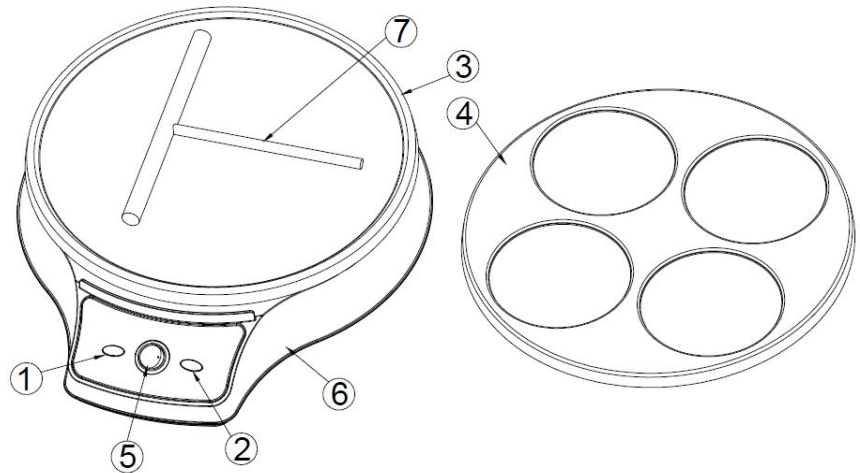

- Unroll the power cord completely.
- Check that the tension in force in the country where you are corresponds to that indicated on the apparatus.
- Connect the apparatus in a correct socket-outlet, (and connected to the ground if the unit is Class I), to avoid any danger.
- Disconnect the power source cable before any operation of cleaning of maintenance and accessories assembly.
- Never modify the appliance in anyway.

Insert the plug into a power outlet; press the on/off button on the unit. The power indication light will illuminate.

When cooking crepes, preheat cooking plate then pour a small amount of butter onto the centre of the cooking plate. Quickly spread the butter in circular movements using the butter spreader until desired diameter of the crepe is achieved.

Allow the crepe to cook until the top surface is no longer runny and the crepe can be moved slightly on the cooking plate.

Insert the spatula under the crepe and turn the crepe over to cook the other side. Cook crepe until just golden.

Remove the crepe from the cooking plate using the spatula. If the last crepe cooked was too dark, Shorten the cooking hours before making your next crepe. At the end of cooking, switch off the unit by pressing the on/off button. Remove the plug from the socket. Allow the appliance to cool then clean before storing.

### CLEANING AND MAINTENANCE

Before cleaning, Always : switch off the appliance, disconnect the apparatus and let it cool.

Clean the outside of the apparatus with a sponge or slightly wet linen.  
The parts (removable) in contact with food like plate, bowl, forks, Spatula etc. can be washed in hot water with sponge and soft detergent or put in the dishwasher.  
Never plunge the apparatus in water or all other liquid !  
Do not use abrasive cleaners, gritting, or metal brush or another cutting object.

Always clean the appliance after every use. Make sure the unit is switched off and unplugged. Let the unit cool completely.

Wipe the baking plate with a damp cloth. When baked-on foods cannot be removed by this method, brush with a little oil. Allow to stand for 5 min, wipe with a damp cloth and then dry thoroughly. Dry the appliance thoroughly before storing.

## STORAGE

- Ensure the unit is completely cool and dry.
- Do not wrap the cord around the appliance, as this will cause damage.
- Keep the appliance in a cool, dry place and out of reach from children.

Wrap the cord around the cord storage under the base and stand upright on the feet under the base. Do not store anything on top.

## GUARANTEE

Before being delivered, all our products are subjected to a rigorous control. This apparatus is guaranteed 24 months starting from the date of purchase by the consumer.

The documents in proof of guarantee are :

- The invoice and
- The filled and stamped warrantee plate (located on side or bottom of the gift box). Without these documents in proof, no free replacement, nor no free repair, can be carried out.

During the warranty period, we deal for free, the defects of the apparatus or the accessories, rising from a defect of materials or manufacture by repair or, replacement. The services within the framework of the guarantee do not involve any extension of the warranty period and does not give right to a new guarantee ! In the event of recourse to the guarantee, bring back the complete apparatus to your retailer, in its original packing, accompanied by the proofs of purchase.

The breakage of parts out of glass or plastic is, in all the cases, not warranted. Defects on the accessories or the wearing parts (for example: coals of engines, hooks, drive belts, remote control of replacement, teeth brushes of replacement, webs etc) as well as cleaning, maintenance or it replacement of wearing parts are not guaranteed and are thus to pay !

In the event of foreign intervention, the guarantee becomes null and void.

After flow of the warranty period, repairs can be carried out, against payment, by a specialized trade or a repair service.

## SPECIFICATIONS

Power supply	220-240V~ 50/60Hz
Power	1000W
Norm	Class I

Made in P.R.C

*The characteristics can change without prior notice.*

This unit is equipped with an electrical outlet with earth and must be earthed in an according plug.

Note : In the event of question concerning the earth or electric connection, please consult a qualified personnel.

In the event of short-circuit, earthing reduces the risk of electric shock while making possible the current to be evacuated by the wire of ground.

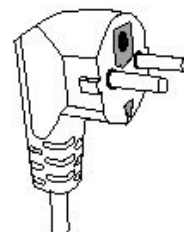

**CAUTION:** In order to minimize the risks of electric shock, In the event of breakdown, not to open the case but to call upon a qualified technician for repairs.

This device complies with EC directives, it was controlled according to all current European directives, applicable such as: electromagnetic compatibility (EMC) and low voltage (LVD).

This device has been designed and manufactured in compliance with the latest regulations and technical requirements for safety.

**Imported by SoTech International  
" LE PERIPOLE " N°A107  
33, Avenue du Marechal de Lattre de Tassigny  
94120 Fontenay sous-bois - France**