

LOCAL AIR CONDITIONER

INSTRUCTION MANUAL



Dear consumer, please read these instructions carefully before use in order to avoid damage due to incorrect use and to better understand the functions of this product. Please pay particular attention to the safety guide. If you pass the device on to a third party, these Operating Instructions must also be handed over. Please keep them for future

IMPORTANT SAFEGUARDS

- ❑ Please read these instructions carefully before use.
- ❑ Keep present instructions for future references.
- ❑ Check that your mains voltage corresponds to that stated on the appliance.
- ❑ Only use the appliance for domestic purposes and household or similar applications such as:
 - staff kitchen areas, in shops, offices and other working environments;
 - by clients in hotels, motels and other residential type environments;
 - Environment type like :
 - Farm Houses • Bed and Breakfast.
- ❑ Only use the appliance in the way indicated in these instructions.
- ❑ Never use this unit near bathtub, shower, wash-hand basins or other containers with water.
- ❑ Never use this apparatus near water projections.
- ❑ Never use this apparatus with the wet hands.
- ❑ If, unfortunately the apparatus is wet, immediately withdraw the cord of the socket-outlet.
- ❑ Inform potential users of these instructions.
- ❑ Never leave the appliance unsupervised when in use.
- ❑ The appliance must be used only for its intended purpose. No responsibility can be taken for any possible damage or injury caused by incorrect use or improper handling.
- ❑ Children and persons with disabilities are not always aware of the danger posed by the use of appliances.
- ❑ This appliance can be used by children aged from 8 years and above and persons with reduced physical, sensory or mental capabilities or lack of experience and knowledge if

they have been given supervision or instruction concerning use of the appliance in a safe way and understand the hazards involved. Children shall not play with the appliance. Cleaning and user maintenance shall not be made by children without supervision.

- Always disconnect the appliance from the supply if it is left unattended and before assembling, disassembling or cleaning
- In order to ensure your children's safety, please keep all packaging (plastic bags, boxes, polystyrene etc.) out of their reach.
- Caution! Do not allow small children to play with the foil:

THERE IS A DANGER OF SUFFOCATION!

- From time to time check the cord for damages. Never use the appliance if cord or appliance shows any signs of damage.
- Never immerse the appliance in water or any other liquid for any reason whatsoever.
- Never place it into the dishwasher.
- Never use the appliance near hot surfaces.
- Do not operate the appliance with a damaged cord or plug, or after the appliance has been damaged in any manner.
- If the supply cord or appliance is damaged, it must be replaced by the manufacturer or its service agent or a similarly qualified person in order to avoid a hazard.
- Disconnect the power source cable before any operation of cleaning of maintenance and accessories assembly.
- Never use the appliance outside and always place it in a dry environment.
- Never use accessories, which are not recommended by the producer. They could constitute a danger to the user and risk to damage the appliance.

- ❑ Never use any other connector than the one provided.
- ❑ Never move the appliance by pulling the cord. Make sure the cord cannot get caught in any way.
- ❑ Never wind the cord around the appliance and do not bend it
- ❑ Ensure that the power cord does not come into contact with hot parts of this unit.
- ❑ Make sure the appliance has cooled down before cleaning and storing it.
- ❑ The temperature of accessible surfaces may be very high when the appliance is operating. Never touch these parts, of apparatus, to avoid burning itself.
- ❑ Make sure the appliance never comes into contact with flammable materials, such as curtains, cloth, etc... & the power cord and plug do not come in contact with water.
- ❑ Before cleaning, always unplug the appliance from the power supply and let it cool down.
- ❑ This appliance is not intended to be operated by means of an external timer or separate remote-control system.
- ❑ Always place the unit on a flat surface. Ensure, also, not to cover the device and not to put anything on it.
- ❑ Always remove the plug from the wall socket when the appliance is not in use.
- ❑ When using an extension lead always make sure that the entire cable is unwound from the reel. Use solely CE approved extension leads. Input power must be at least 16A, 250V, 3000W.
- ❑ Incorrect operation and improper use can damage the appliance and cause injury to the user.
- ❑ This device, designed for home use, complies with standards relating to this type of product.
- ❑ The appliance must be used and rested on flat & stable surface.

- The item must not be left unattended when it is connected to main supply.
- The item is not to be used, if it has been dropped or if there are visible signs of damage or if it is leaking.
- This appliance is only intended for household use.
- The appliance must be installed, used and stored in a room larger than 4 m².

(*) Qualified Person : the manufacturer's or importer's service technician or any other person qualified, authorized and competent to carry out this type of repair.

GENERAL INFORMATION

The symbol "OPEN BOOK" means a recommendation to read important things contained in the record.



The symbol "BIN" crossed out, abbreviation WEEE (Waste of Electrical and Electronic Equipment) means that at the end of life, it should not be discarded with household waste, but filed to the sorting of the locality. Waste recovery can help preserve our environment.



The symbol "CE" is the guarantee of compliance with harmonized European standards, voluntary, reflecting the essential requirements into technical specifications. These standards are not mandatory but are guarantees of compliance with essential requirements.



The symbol ROHS (Restriction of use of some Hazardous Substances) on the Environmental



Protection, certifies that for each of the five hazardous substances • Lead • Mercury • (hexavalent) chromium • products for protection against flames PBB and PBDE, the peak concentration is equal to or less than 0.1% of the weight of homogeneous material, and 0.01% for the 6th • cadmium.

The symbol "FLAMMABLE PRODUCTS" means that certain components or liquids of this device may ignite easily in contact with a flame or spark, or under the influence of heat and take all precautions accordingly.



The symbol "TRIMAN" indicates that the consumer is invited to dispose the product as part of a separate collection (eg recycling bin, waste, voluntary intake point).



For more information : <http://www.quefairedemesdechets.fr>

CLEANING AND MAINTENANCE

Always switch off the appliance, disconnect the apparatus and let it cool before cleaning.

Clean the outside of the apparatus with a sponge or slightly wet linen.

Never plunge the apparatus in water or all other liquid!

Do not use abrasive cleaners, gritting, or metal brush or another cutting object.

SAFETY SECURITY

The appliance shall be installed in accordance with national wiring regulations.

Special instructions for flammable refrigerants

WARNING

Do not use means to accelerate the defrosting process or to clean, other than those recommended by the manufacturer. The appliance shall be stored in a room without continuously operating ignition sources (for example: open flames, an operating gas appliance or an operating electric heater. Do not pierce or burn.

Be aware that refrigerants may not contain an odour.

The installation of pipe-work shall be kept to a minimum.

Pipe-work shall be protected from physical damage and, in the case of **flammable refrigerants**, shall not be installed in an unventilated space, if that space is smaller than 4 m².

Compliance with national gas regulations shall be observed.

Mechanical connections made in accordance with 22.118 of EN 60335-2-40 shall be accessible for maintenance purposes.

Follow this manual for handling, installation, cleaning, servicing and disposal of refrigerant.

Keep any required ventilation openings clear of obstruction.

Servicing shall be performed only as recommended by the manufacturer.

The appliance shall be stored in a well-ventilated area where the room size corresponds to the room area as specified for operation.

The appliance shall be stored in a room without continuously operating open flames (for example an operating gas appliance) and ignition sources (for example an operating electric heater).

The appliance shall be stored so as to prevent mechanical damage from occurring.

Any person who is involved with working on or breaking into a refrigerant circuit should hold a current valid certificate from an industry-accredited assessment authority, which authorises their competence to handle refrigerants safely in accordance with an industry recognised assessment specification.

Servicing shall only be performed as recommended by the equipment manufacturer. Maintenance and repair requiring the assistance of other skilled personnel shall be carried out under the supervision of the person competent in the use of flammable refrigerants.

All working procedure that affects safety means shall only be carried by competent persons.



Warning; Risk of fire/Flammable materials.



Read operator's manual.



operator's manual; operating instructions



Service indicator; read technical manual.

INFORMATION ON SERVICING

Checks to the area

Prior to beginning work on systems containing **flammable refrigerants**, safety checks are necessary to ensure that the risk of ignition is minimised. For repair to the refrigerating system, following precautions shall be completed prior to conducting work on the system.

Work procedure

Work shall be undertaken under a controlled procedure so as to minimise the risk of a flammable gas or vapour being present while the work is being performed.

General work area

All maintenance staff and others working in the local area shall be instructed on the nature of work being carried out. Work in confined spaces shall be avoided. The area around the workspace shall be sectioned off. Ensure that the conditions within the area have been made safe by control of flammable material.

Checking for presence of refrigerant

The area shall be checked with an appropriate refrigerant detector prior to and during work, to ensure the technician is aware of potentially toxic or flammable atmospheres. Ensure that the leak detection equipment being used is suitable for use with all applicable refrigerants, i.e. non-sparking, adequately sealed or intrinsically safe.

Presence of fire extinguisher

If any hot work is to be conducted on the refrigeration equipment or any associated parts, appropriate fire

extinguishing equipment shall be available to hand. Have a dry powder or CO2 fire extinguisher adjacent to the charging area.

No ignition sources

No person carrying out work in relation to a refrigeration system which involves exposing any pipe work shall use any sources of ignition in such a manner that it may lead to the risk of fire or explosion. All possible ignition sources, including cigarette smoking, should be kept sufficiently far away from the site of installation, repairing, removing and disposal, during which refrigerant can possibly be released to the surrounding space. Prior to work taking place, the area around the equipment is to be surveyed to make sure that there are no flammable hazards or ignition risks. "No Smoking" signs shall be displayed.

Ventilated area

Ensure that the area is in the open or that it is adequately ventilated before breaking into the system or conducting any hot work. A degree of ventilation shall continue during the period that the work is carried out. The ventilation should safely disperse any released refrigerant and preferably expel it externally into the atmosphere.

Checks to the refrigeration equipment

Where electrical components are being changed, they shall be fit for the purpose and to the correct specification. At all times the manufacturer's maintenance and service guidelines shall be followed. If in doubt, consult the manufacturer's technical department for assistance.

The following checks shall be applied to installations using flammable refrigerants:

- the charge size is in accordance with the room size within which the refrigerant containing parts are installed;*
- the ventilation machinery and outlets are operating adequately and are not obstructed;*
- if an indirect refrigerating circuit is being used, the secondary circuit shall be checked for the presence of refrigerant;*
- marking to the equipment continues to be visible and legible. Markings and signs that are illegible shall be corrected;*
- refrigeration pipe or components are installed in a position where they are unlikely to be exposed to any substance which may corrode refrigerant containing components, unless the components are constructed of materials which are inherently resistant to being corroded or are suitably protected against being so corroded.*

Checks to electrical devices

Repair and maintenance to electrical components shall include initial safety checks and component inspection procedures. If a fault exists that could compromise safety, then no electrical supply shall be connected to the circuit until it is satisfactorily dealt with. If the fault cannot be corrected immediately but it is necessary to continue operation, an adequate temporary solution shall be used. This shall be reported to the owner of the equipment so all parties are advised.

Initial safety checks shall include:

- that capacitors are discharged: this shall be done in a safe manner to avoid possibility of sparking;
- that no live electrical components and wiring are exposed while charging, recovering or purging the system;
- that there is continuity of earth bonding.

Repairs to sealed components

1 During repairs to sealed components, all electrical supplies shall be disconnected from the equipment being worked upon prior to any removal of sealed covers, etc. If it is absolutely necessary to have an electrical supply to equipment during servicing, then a permanently operating form of leak detection shall be located at the most critical point to warn of a potentially hazardous situation.

2 Particular attention shall be paid to the following to ensure that by working on electrical components, the casing is not altered in such a way that the level of protection is affected. This shall include damage to cables, excessive number of connections, terminals not made to original specification, damage to seals, incorrect fitting of glands, etc.

Ensure that the apparatus is mounted securely.

Ensure that seals or sealing materials have not degraded to the point that they no longer serve the purpose of preventing the ingress of flammable atmospheres. Replacement parts shall be in accordance with the manufacturer's specifications.

NOTE The use of silicon sealant can inhibit the effectiveness of some types of leak detection equipment. Intrinsically safe components do not have to be isolated prior to working on them.

Repair to intrinsically safe components

Do not apply any permanent inductive or capacitance loads to the circuit without ensuring that this will not exceed the permissible voltage and current permitted for the equipment in use.

Intrinsically safe components are the only types that can be worked on while live in the presence of a flammable atmosphere. The test apparatus shall be at the correct rating.

Replace components only with parts specified by the manufacturer. Other parts may result in the ignition of refrigerant in the atmosphere from a leak.

Cabling

Check that cabling will not be subject to wear, corrosion, excessive pressure, vibration, sharp edges or any other adverse environmental effects. The check shall also take into account the effects of aging or continual vibration from sources such as compressors or fans.

Detection of flammable refrigerants

Under no circumstances shall potential sources of ignition be used in the searching for or detection of refrigerant leaks. A halide torch (or any other detector using a naked flame) shall not be used.

Leak detection methods

The following leak detection methods are deemed acceptable for all refrigerant systems.

Electronic leak detectors may be used to detect refrigerant leaks but, in the case of **flammable refrigerants**, the sensitivity may not be adequate, or may need re-calibration. (Detection equipment shall be calibrated in a refrigerant-free area.) Ensure that the detector is not a potential source of ignition and is suitable for the refrigerant used. Leak detection equipment shall be set at a percentage of the *LFL* of the refrigerant and shall be calibrated to the refrigerant employed, and the appropriate percentage of gas (25 % maximum) is confirmed.

Leak detection fluids are suitable for use with most refrigerants but the use of detergents containing chlorine shall be avoided

as the chlorine may react with the refrigerant and corrode the copper pipe-work.

If a leak is suspected, all naked flames shall be removed/extinguished.

If a leakage of refrigerant is found which requires brazing, all of the refrigerant shall be recovered from the system, or isolated (by means of shut off valves) in a part of the system remote from the leak. For appliances containing **flammable refrigerants**, oxygen free nitrogen (OFN) shall then be purged through the system both before and during the brazing process.

Removal and evacuation

When breaking into the refrigerant circuit to make repairs – or for any other purpose – conventional procedures shall be used. However, for **flammable refrigerants** it is important that best practice is followed since flammability is a consideration. The following procedure shall be adhered to:

- remove refrigerant;
- purge the circuit with inert gas;
- evacuate;
- purge again with inert gas;
- open the circuit by cutting or brazing.

The refrigerant charge shall be recovered into the correct recovery cylinders. For appliances containing **flammable refrigerants**, the system shall be “flushed” with OFN to render the unit safe. This process may need to be repeated several times. Compressed air or oxygen shall not be used for purging refrigerant systems.

For appliances containing **flammable refrigerants**, flushing shall be achieved by breaking the vacuum in the system with OFN and continuing to fill until the working pressure is achieved, then venting to atmosphere, and finally pulling down

to a vacuum. This process shall be repeated until no refrigerant is within the system. When the final OFN charge is used, the system shall be vented down to atmospheric pressure to enable work to take place. This operation is absolutely vital if brazing operations on the pipe-work are to take place.

Ensure that the outlet for the vacuum pump is not close to any ignition sources and that ventilation is available.

Charging procedures

In addition to conventional charging procedures, the following requirements shall be followed.

- Ensure that contamination of different refrigerants does not occur when using charging equipment. Hoses or lines shall be as short as possible to minimise the amount of refrigerant contained in them.
- Cylinders shall be kept upright.
- Ensure that the refrigeration system is earthed prior to charging the system with refrigerant.
- Label the system when charging is complete (if not already).
- Extreme care shall be taken not to overfill the refrigeration system.

Prior to recharging the system, it shall be pressure-tested with the appropriate purging gas. The system shall be leak-tested on completion of charging but prior to commissioning. A follow up leak test shall be carried out prior to leaving the site.

Decommissioning

Before carrying out this procedure, it is essential that the technician is completely familiar with the equipment and all its detail. It is recommended good practice that all refrigerants are

recovered safely. Prior to the task being carried out, an oil and refrigerant sample shall be taken in case analysis is required prior to re-use of reclaimed refrigerant. It is essential that electrical power is available before the task is commenced.

a) Become familiar with the equipment and its operation.

b) Isolate system electrically.

c) Before attempting the procedure, ensure that:

- mechanical handling equipment is available, if required, for handling refrigerant cylinders;
- all personal protective equipment is available and being used correctly;
- the recovery process is supervised at all times by a competent person;
- recovery equipment and cylinders conform to the appropriate standards.

d) Pump down refrigerant system, if possible.

e) If a vacuum is not possible, make a manifold so that refrigerant can be removed from various parts of the system.

f) Make sure that cylinder is situated on the scales before recovery takes place.

g) Start the recovery machine and operate in accordance with manufacturer's instructions.

h) Do not overfill cylinders. (No more than 80 % volume liquid charge).

i) Do not exceed the maximum working pressure of the cylinder, even temporarily.

j) When the cylinders have been filled correctly and the process completed, make sure that the cylinders and the equipment are removed from site promptly and all isolation valves on the equipment are closed off.

k) Recovered refrigerant shall not be charged into another refrigeration system unless it has been cleaned and checked.

Labelling

Equipment shall be labelled stating that it has been de-commissioned and emptied of refrigerant. The label shall be dated and signed. For appliances containing **flammable refrigerants**, ensure that there are labels on the equipment stating the equipment contains flammable refrigerant.

Recovery

When removing refrigerant from a system, either for servicing or decommissioning, it is recommended good practice that all refrigerants are removed safely.

When transferring refrigerant into cylinders, ensure that only appropriate refrigerant recovery cylinders are employed. Ensure that the correct number of cylinders for holding the total system charge are available. All cylinders to be used are designated for the recovered refrigerant and labelled for that refrigerant (i.e. special cylinders for the recovery of refrigerant). Cylinders shall be complete with pressure-relief valve and associated shut-off valves in good working order. Empty recovery cylinders are evacuated and, if possible, cooled before recovery occurs.

The recovery equipment shall be in good working order with a set of instructions concerning the equipment that is at hand and shall be suitable for the recovery of all appropriate refrigerants including, when applicable, **flammable refrigerants**. In addition, a set of calibrated weighing scales shall be available and in good working order. Hoses shall be complete with leak-free disconnect couplings and in good condition. Before using the recovery machine, check that it is in satisfactory working order, has been properly maintained and that any associated electrical components are sealed to prevent ignition in the event of a refrigerant release. Consult manufacturer if in doubt.

The recovered refrigerant shall be returned to the refrigerant supplier in the correct recovery cylinder, and the relevant waste transfer note arranged. Do not mix refrigerants in recovery units and especially not in cylinders.

If compressors or compressor oils are to be removed, ensure that they have been evacuated to an acceptable level to make certain that flammable refrigerant does not remain within the lubricant. The evacuation process shall be carried out prior to returning the compressor to the suppliers. Only electric heating to the compressor body shall be employed to accelerate this process. When oil is drained from a system, it shall be carried out safely.

TO KNOW THE DEVICE

1. handle
2. Control panel
3. Adjustable ventilation grille
4. Roulette

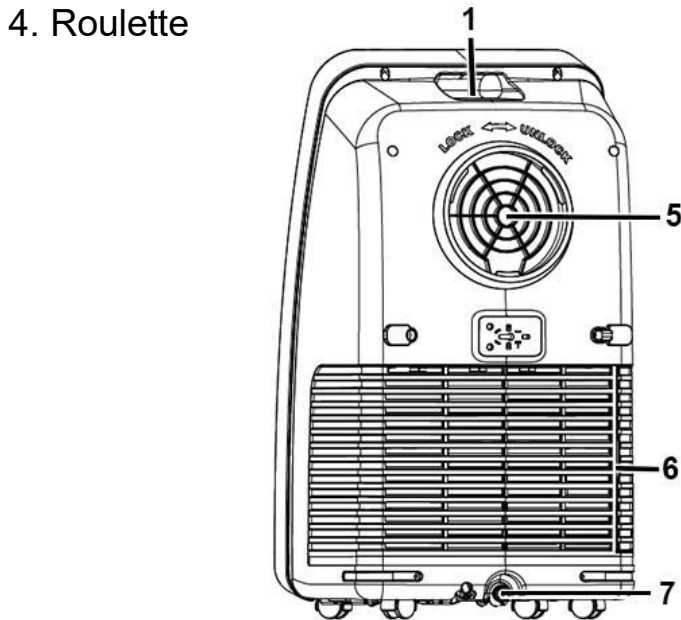
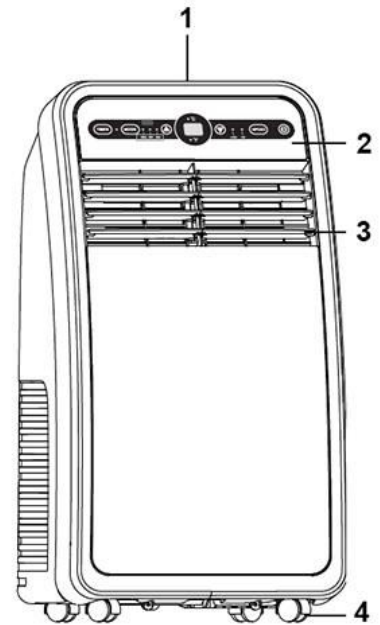

5. Air outlet
6. Air inlet (connectable)
7. Drainage nozzle

8. Remote control.
9. Vent pipe for hot air.
10. Window adjustable sealing plate
(Connectable to the drain pipe.)

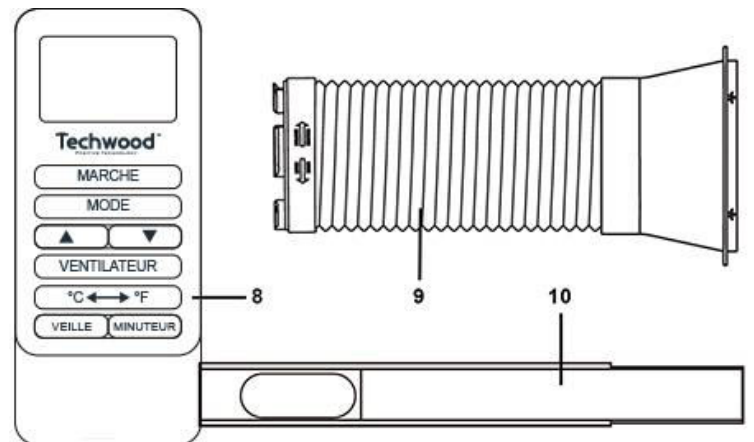

CONTROL PANEL AND REMOTE CONTROL

1. Power button
Press the key to turn the device On or Off.
2. Mode key
Press the key to select : Cool, Vent, Dry.
3. 2-function adjustment keys. A. Temperature B. operating time.
In "cool" mode Press these buttons to increase or decrease the set temperature.
After activating the Timer (5), press these buttons to increase or decrease the operating time.
Note : Press both up and down keys simultaneously to change temperature in Celsius or Fahrenheit degrees and back.
4. Ventilation speed setting button.
Press the key to select the fan speed - Soft or Strong.
5. Timer button
Press this key in **"sleep" mode** to set the activation time. Then on the (3) keys to set the duration.
Press this key in **"On" mode** to stop the timer.
6. Display of temperature and time. (Device only)
This window displays the programmed temperature and time.
7. Remote control wave receiver
This receiver is used to get the signal emitted by the remote control.
Remote control only
8. ° C or ° F switch key.
Press this key to change the unit of measurement.
9. Sleep key
In cooling mode, press the "Sleep" button on the remote control to select this mode.
In this case, the fan will run more slowly.

FIRST USE

- remove the appliance and all accessories carefully.
- Clean the outside of the appliance with a damp sponge or cloth and wipe it.
- Install the appliance on a table or flat, stable and horizontal surface. Make sure there is enough space to operate the machine properly.
- Unwind the power cord completely.
- Check that the voltage in the country where you are, corresponds to that indicated on the device.
- Connect the appliance to a good electrical outlet, (earthed if the appliance is class I), to avoid any danger.

- Disconnect the power cable from the power supply before performing maintenance, cleaning, and accessory mounting.
- Never modify the device.

INSTALLATION

A. Place the unit in a flat, dry place and keep it 50 cm away from any surrounding object. (Curtain, curtain, etc.).

B. Screw the exhaust tube (counter clockwise) to the air outlet behind the panel (5).

C. Insert the hot air exhaust pipe into the hole of the window sealing plate and adjust the opening width of the window to match the sealing plate.

Note : the length of the sealing plate is adjustable.

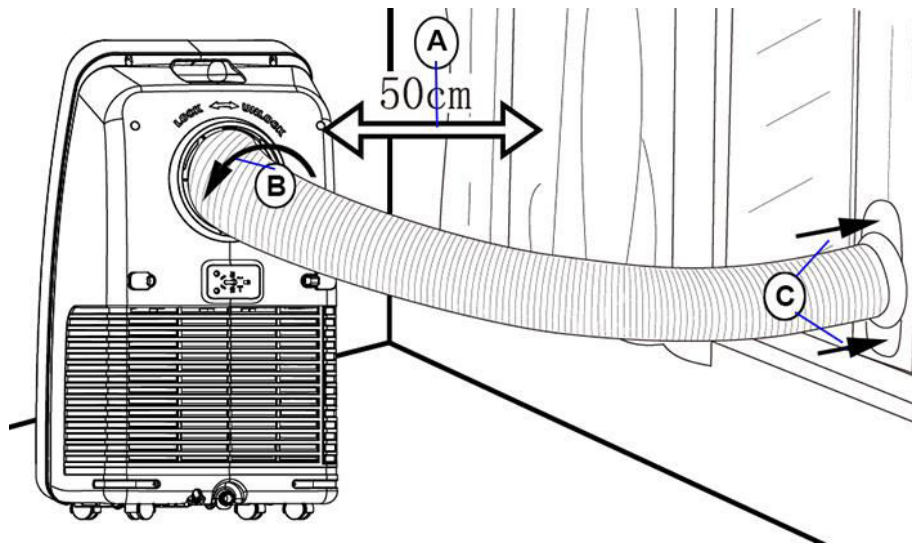

Notes : It is important to keep the air duct the most linear possible. Avoid being bent.

Incorrect installation will affect the work of the air conditioner.

Ensure that air can flow easily through the air duct.

The sealing plate fits with vertical and horizontal windows.

The exhaust duct is specially designed for this model. Do not replace or lengthen it. This could lead to a malfunctioning of the device.

The maximum length of the pipe is 1.50 m. it is always better that the developed length is as short as possible and the most horizontal possible.

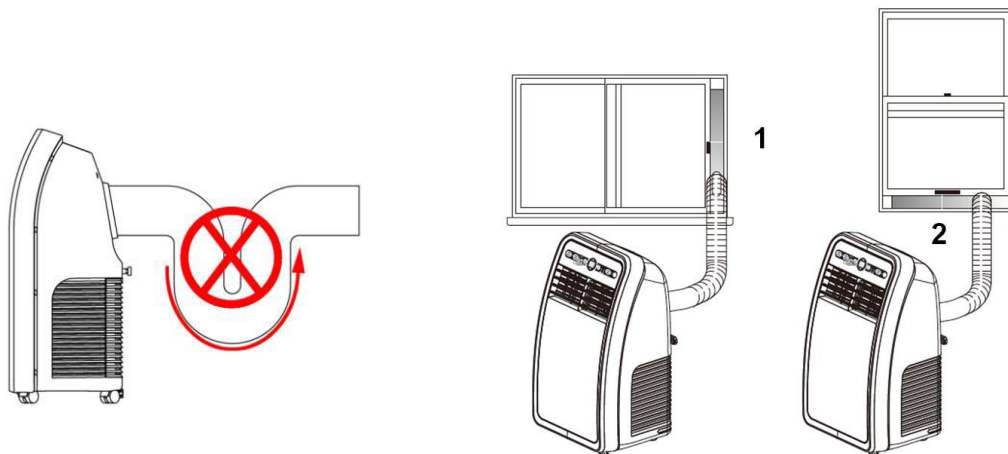

USE

Cooling mode

When the air conditioner goes into cooling mode, after turning on the power, the cooling indicator lights up.

Press the "Up / Down" keys to set the desired temperature. (from 16 to 30 ° C).

Press the "Speed" button to choose the speed. (Sweet or Strong)

Fan mode

By pressing the Mode key (2), it is possible to select the "Ventilation" mode. Press either the remote control or the control panel. the ventilation indicator lights up.

Press the "Speed" button to choose the speed. (Sweet or Strong)

Note: In this mode, temperature cannot be set.

Dehumidifier mode

By pressing the Mode key (2) it is possible to select the mode "Dehumidify". Press either on the remote control or on the control panel. the dehumidification indicator lights up.

Remove the drain cork and insert one end of the hose to collect the drain water.

The other end of the hose should be introduced into a suitable container such as a bottle or small jerry can.

In dehumidification mode, when the temperature reaches ≥ 17 ° C (62 ° F), the compressor starts. When the ambient temperature drops below ≤ 15 ° C (59 °

F), the compressor stops. When the temperature rises to an ambient temperature above 17 ° C, the compressor protection system will restart it 3 minutes later).

Notes : In dehumidification mode :

- the fan operates by default at low speed and the speed of the fan cannot be adjusted.*
- Remove the exhaust pipe, otherwise the performance of dehumidification will be less and the alarm "FL", indicating that the water tank is full, may run.*

STORAGE

- Ensure the unit is completely cool and dry.
- Do not wrap the cord around the appliance, as this will cause damage.
- Keep the appliance in a cool, dry place.

GUARANTEE

Before being delivered, all our products are subjected to a rigorous control. This apparatus is guaranteed 24 months starting from the date of purchase by the consumer.

The documents in proof of guarantee are:

- The invoice and
- The filled and stamped warranty plate (located on side or bottom of the gift box). Without these documents in proof, no free replacement, nor no free repair, can be carried out.

During the warranty period, we deal for free, the defects of the apparatus or the accessories, rising from a defect of materials or manufacture by repair or, replacement. The services within the framework of the guarantee do not involve any extension of the warranty period and does not give right to a new guarantee! In the event of recourse to the guarantee, bring back the complete apparatus to your retailer, in its original packing, accompanied by the proofs of purchase.

The breakage of parts out of glass or plastic is, in all the cases, not warranted.

Defects on the accessories or the wearing parts (for example: coils of engines, hooks, drive belts, remote control of replacement, teeth brushes of replacement, webs etc) as well as cleaning, maintenance or it replacement of wearing parts are not guaranteed and are thus to pay!

In the event of foreign intervention, the guarantee becomes null and void.

After flow of the warranty period, repairs can be carried out, against payment, by a specialized trade or a repair service.

SPECIFICATIONS

Power supply	220-240V~ 50Hz
Norm	Class I
Refrigerant	R 290 / 150g
Sound level	65 dB(A)

Made in PRC

The characteristics can change without prior notice.

CAUTION: In order to minimize the risks of electric shock, In the event of breakdown, not to open the case but to call upon a qualified technician for repairs.

This apparatus satisfied EC directives, it was controlled according to all the European current directives, like: electromagnetic compatibility (EMC) and low tension (LVD).

This apparatus was designed and manufactured in respect of the last safety regulations and technical specifications.

**Imported by Sotech International
" LE PERIPOLE " N°A-107
33, Avenue du Marechal de Lattre de Tassigny
94120 Fontenay sous-bois – France**

Product Information

Supplier name	TECHWOOD	
Model identifier	TCL-7001	
	Rated value	Measured value
Capacity for cooling	2.05 kW	2.017 kW
Capacity for heating	N/A	N/A
Power input cooling	0.785 kW	0.773 kW
Power input for heating	N/A	N/A
Energy efficiency ratio	2.60	2.61
Coefficient of performance	N/A	N/A
Power consumption in thermostat off-mode	N/A	
Power consumption in standby mode	0.63 W	
Electricity consumption of single/double duct appliances (indicates for cooling and heating separately)	SD:0.8 kWh/h for cooling	
Sound power level	65,0 dB(A)	
Global warming potential	3 kgCO ₂ eq.	
Contact details for obtaining more information	Sotech International 33 av du Maréchal de Lattre de Tassigny 94120 Fontenays-sous-Bois - France	

Product Fiche

Supplier name	TECHWOOD	
Model identifier	TCL-7001	
Sound power level	65 dB(A)	
Refrigerant	R290 / 150g	Global Warming Potential : 3 kgCO ₂ eq.
Refrigerant leakage contributes to climate change. Refrigerant with lower global warming potential (GWP) would contribute less to global warming than a refrigerant with higher GWP, if leaked to the atmosphere. This appliance contains a refrigerant fluid with a GWP equal to (3). This means that if 1 kg of this refrigerant fluid would be leaked to the atmosphere, the impact on global warming would be 3 times higher than 1 kg of CO ₂ , over a period of 100 years. Never try to interfere with the refrigerant circuit yourself or disassemble the product yourself and always ask a professional.		
Energy efficiency	Class A	
Hourly electricity consumption	SD: 0.8 kWh/60 minutes for cooling. Energy consumption 0.8 kWh per 60 minutes, based on standard test results. Actual energy consumption will depend on how the appliance is used and where it is located.	
Cooling capacity	2.1 kW	
Contact details for obtaining more information	Sotech International 33 av du Maréchal de Lattre de Tassigny 94120 Fontenays-sous-Bois - France	