

Test Report issued under the responsibility of:

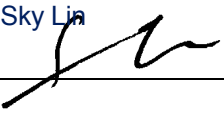

TEST REPORT IEC 60335-2-15 Safety of household and similar electrical appliances Part 2: Particular requirements for appliances for heating liquids	
Report Number	GZES170801410901
Date of issue	2018-05-18
Total number of pages	149
Name of Testing Laboratory preparing the Report	SGS-CSTC Standards Technical Services Co., Ltd. Shunde Branch
Applicant's name	Guangdong Gaobo Electrical Appliance Co., Ltd.
Address	Area Gaoling West Industrial Park, Liangdong Town, Lianjiang City, Guangdong, China
Test specification:	
Standard	IEC 60335-2-15:2012, AMD1:2016 for use in conjunction with IEC 60335-1:2010, AMD1:2013, AMD2:2016
Test procedure	SGS GS procedure
Non-standard test method	N/A
Test Report Form No.	IEC60335_2_15O
Test Report Form(s) Originator	IMQ S.p.A.
Master TRF	Dated 2017-09
Copyright © 2017 IEC System of Conformity Assessment Schemes for Electrotechnical Equipment and Components (IECEE System). All rights reserved.	
This publication may be reproduced in whole or in part for non-commercial purposes as long as the IECEE is acknowledged as copyright owner and source of the material. IECEE takes no responsibility for and will not assume liability for damages resulting from the reader's interpretation of the reproduced material due to its placement and context.	
If this Test Report Form is used by non-IECEE members, the IECEE/IEC logo and the reference to the CB Scheme procedure shall be removed.	
This report is not valid as a CB Test Report unless signed by an approved CB Testing Laboratory and appended to a CB Test Certificate issued by an NCB in accordance with IECEE 02.	
General disclaimer:	
The test results presented in this report relate only to the object tested. This report shall not be reproduced, except in full, without the written approval of the Issuing CB Testing Laboratory. The authenticity of this Test Report and its contents can be verified by contacting the NCB, responsible for this Test Report.	

Test item description :	Rice cooker
Trade Mark :	--
Manufacturer	Same as applicant
Model/Type reference :	See page 6 and 7
Ratings	220 V – 240 V; 50 Hz / 60 Hz; Class I; See page 6 and 7 for rated power

Responsible Testing Laboratory (as applicable), testing procedure and testing location(s):		
<input checked="" type="checkbox"/>	CB Testing Laboratory:	SGS-CSTC Standards Technical Services Co., Ltd. Shunde Branch
Testing location/ address		Building 1, European Industrial Park, No.1, Shunhe South Road, Wusha, Daliang, Shunde District, Foshan, Guangdong, China
Tested by (name, function, signature)..... :		Leif Hong 
Approved by (name, function, signature) .. :		Sky Lin 
<input type="checkbox"/>	Testing procedure: CTF Stage 1:	
Testing location/ address		
Tested by (name, function, signature)..... :		
Approved by (name, function, signature) .. :		
<input type="checkbox"/>	Testing procedure: CTF Stage 2:	
Testing location/ address		
Tested by (name, function, signature)..... :		
Witnessed by (name, function, signature) . :		
Approved by (name, function, signature) .. :		
<input type="checkbox"/>	Testing procedure: CTF Stage 3:	
<input type="checkbox"/>	Testing procedure: CTF Stage 4:	
Testing location/ address		
Tested by (name, function, signature)..... :		
Witnessed by (name, function, signature) . :		
Approved by (name, function, signature) .. :		
Supervised by (name, function, signature) :		

List of Attachments (including a total number of pages in each attachment):

Attachment 1: EU group differences (15 pages);
 Attachment 2: EN 60335-1:2012 /A13:2017 (1 page);
 Attachment 3: circuit diagram (4 pages);
 Attachment 4: photo document (18 pages);

Summary of testing:

Tests performed (name of test and test clause):

IEC 60335-2-15: 2012 +A1: 2016
 IEC 60335-1:2010 + A1: 2013 + A2: 2016
 After reviewed, models RC03-Y, RC06B-AY3, RC28A-GY1, RC120A-AY2, DRC10S1-GWA3, DRC36S-GPA3, SRC06S1-WPY3 and SRC28S-WPY3 were subjected to full tests. Models RC03-X, RC06B-AX3, RC28A-NX3, DRC36C-CWA3, SRC06S1-WPX3 and SRC28C-UWX3 were subjected to tests of clause 11, 13, 15, 16, construction check.
 Other models were subjected to construction check.
 The submitted samples fulfil the above requirements.

Testing location:

See page 3

Summary of compliance with National Differences (List of countries addressed):

For models with power switch:
 Including CENELEC common modifications and national differences for Germany
 EK decisions according to German ProdSG have been taken into account.
 PAH risk evaluation according to AfPS GS 2014:01 PAK.

The product fulfils the requirements of

EN 60335-2-15: 2016
 EN 60335-1:2012 + A11:2014 + A13:2017
 EN 62233:2008

Copy of marking plate:

The artwork below may be only a draft. The use of certification marks on a product must be authorized by the respective NCBs that own these marks.

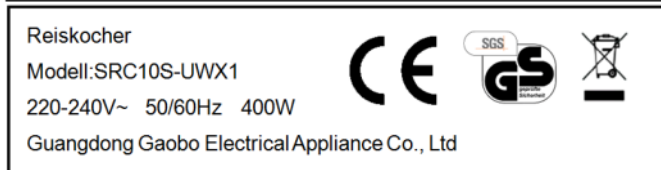
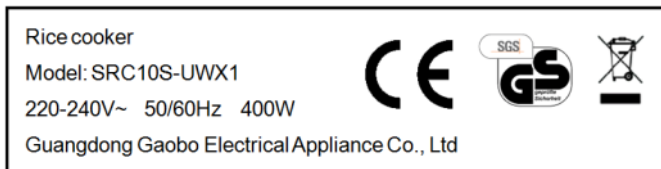

Remarks:

Rating labels for others model are identical with above, except for different model name and rated power.

1. The Height of CE logo shall not be less than 5 mm; Height of WEEE logo shall not be less than 7 mm;
2. As declared by the applicant, the importer (**and manufacturer, if it is different**)'s name, registered trade name or registered trade mark and the postal address will be marked on the products before being place on the market. The contact details shall be in a language easily understood by end-users and market surveillance authorities.
3. Marking on the packaging or in a document accompanying the electrical equipment is only acceptable if it is not possible to place such markings on the product.

Test item particulars: Classification of installation and use: Portable appliance for household use only Supply Connection: Non-detachable power cord fitted with a plug or appliance inlet, see page 7 for details:	
Possible test case verdicts: - test case does not apply to the test object.....: N/A - test object does meet the requirement: P - test object does not meet the requirement.....: F	
Testing: Date of receipt of test item: 2017-09-01 Date (s) of performance of tests: 2017-09-01 to 2018-05-15	
General remarks: "(See Enclosure #)" refers to additional information appended to the report. "(See appended table)" refers to a table appended to the report. Throughout this report a <input checked="" type="checkbox"/> comma / <input type="checkbox"/> point is used as the decimal separator. This document is issued by the Company subject to its General Conditions of Service, available on request or accessible at http://www.sgs.com/en/Terms-and-Conditions.aspx and, for electronic format documents, subject to Terms and Conditions for Electronic Documents at http://www.sgs.com/en/Terms-and-Conditions/Terms-e-Document.aspx . Attention is drawn to the limitation of liability, indemnification and jurisdiction issues defined therein. Any holder of this document is advised that information contained hereon reflects the Company's findings at the time of its intervention only and within the limits of Client's instructions, if any. The Company's sole responsibility is to its Client and this document does not exonerate parties to a transaction from exercising all their rights and obligations under the transaction documents. This document cannot be reproduced except in full, without prior written approval of the Company. Any unauthorized alteration, forgery or falsification of the content or appearance of this document is unlawful and offenders may be prosecuted to the fullest extent of the law. Unless otherwise stated the results shown in this test report refer only to the sample(s) tested and such sample(s) are retained for 3 months only.	
Manufacturer's Declaration per Sub-clause 4.2.5 of IECEE 02:	
The application for obtaining a CB Test Certificate includes more than one factory location and a declaration from the Manufacturer stating that the sample(s) submitted for evaluation is (are) representative of the products from each factory has been provided.....:	<input type="checkbox"/> Yes <input checked="" type="checkbox"/> Not applicable
When differences exist; they shall be identified in the General product information section.	
Name and address of factory (ies): Guangdong Gaobo Electrical Appliance Co., Ltd. Area Gaoling West Industrial Park, Liangdong Town, Lianjiang City, Guangdong, China	

General product information:

Appliance is for household and indoor use only.

Model list:

Model	Rated Power (W)	Rated Capacity (L)	Type Y attachment	Appliance inlet	Thermal cut-out	Thermostat (keep warm function)	Keep warm heater
RC03-y	220	0,3L	Yes	Yes	No	No	No
RC06A-*yz	300	0,6L	Yes	Yes	Yes	Yes	Yes
RC06B-*yz	350	0,6L	Yes	Yes	Yes	Yes	Yes
RC08-*yz	350	0,8L	Yes	Yes	Yes	Yes	Yes
RC10A-*yz	400	1,0L	Yes	Yes	Yes	Yes	Yes
RC10B-*yz	450	1,0L	Yes	Yes	Yes	Yes	Yes
RC12A-*yz	400	1,2L	Yes	Yes	Yes	Yes	Yes
RC12B-*yz	450	1,2L	Yes	Yes	Yes	Yes	Yes
RC15A-*yz	500	1,5L	Yes	Yes	Yes	Yes	Yes
RC15B-*yz	550	1,5L	Yes	Yes	Yes	Yes	Yes
RC18A-*yz	700	1,8L	Yes	Yes	Yes	Yes	Yes
RC18B-*yz	650	1,8L	Yes	Yes	Yes	Yes	Yes
RC18C-*yz	750	1,8L	Yes	Yes	Yes	Yes	Yes
RC22A-*yz	900	2,2L	Yes	Yes	Yes	Yes	Yes
RC22B-*yz	850	2,2L	Yes	Yes	Yes	Yes	Yes
RC28A-*yz	1000	2,8L	Yes	Yes	Yes	Yes	Yes
RC28B-*yz	950	2,8L	Yes	Yes	Yes	Yes	Yes
RC36A-*yz	1300	3,6L	Yes	No	Yes	Yes	No
RC36B-*yz	1250	3,6L	Yes	No	Yes	Yes	No
RC42A-*yz	1600	4,2L	Yes	No	Yes	Yes	No
RC42B-*yz	1550	4,2L	Yes	No	Yes	Yes	No
RC56A-*yz	2000	5,6L	Yes	No	Yes	Yes	No
RC56B-*yz	1950	5,6L	Yes	No	Yes	Yes	No
RC78A-*yz	2200	7,8L	Yes	No	Yes	Yes	No
RC78B-*yz	2250	7,8L	Yes	No	Yes	Yes	No
RC80A-*yz	2500	8,0L	Yes	No	Yes	Yes	No
RC80B-*yz	2250	8,0L	Yes	No	Yes	Yes	No
RC85A-*yz	2800	8,5L	Yes	No	Yes	Yes	No
RC85B-*yz	2650	8,5L	Yes	No	Yes	Yes	No
RC100A-*yz	3000	10L	Yes	No	Yes	Yes	No
RC100B-*yz	3200	10L	Yes	No	Yes	Yes	No
RC120A-*yz	3500	12L	Yes	No	Yes	Yes	No
RC120B-*yz	3250	12L	Yes	No	Yes	Yes	No
SRC06a-*xyz	300	0,6L	Yes	Yes	Yes	Yes	Yes
SRC06a1-*xyz	350	0,6L	Yes	Yes	Yes	Yes	Yes
SRC10a-*xyz	400	1,0L	Yes	Yes	Yes	Yes	Yes
SRC10a1-*xyz	450	1,0L	Yes	Yes	Yes	Yes	Yes

SRC12a-*xyz	400	1,2L	Yes	Yes	Yes	Yes	Yes
SRC12a1-*xyz	450	1,2L	Yes	Yes	Yes	Yes	Yes
SRC15a-*xyz	500	1,5L	Yes	Yes	Yes	Yes	Yes
SRC15a1-*xyz	550	1,5L	Yes	Yes	Yes	Yes	Yes
SRC18a-*xyz	700	1,8L	Yes	Yes	Yes	Yes	Yes
SRC18a1-*xyz	650	1,8L	Yes	Yes	Yes	Yes	Yes
SRC18a2-*xyz	600	1,8L	Yes	Yes	Yes	Yes	Yes
SRC22a-*xyz	900	2,2L	Yes	Yes	Yes	Yes	Yes
SRC22a1-*xyz	850	2,2L	Yes	Yes	Yes	Yes	Yes
SRC28a-*xyz	1000	2,8L	Yes	Yes	Yes	Yes	Yes
SRC28a1-*xyz	950	2,8L	Yes	Yes	Yes	Yes	Yes
DRC10a-*xmz	400	1,0L	No	Yes	Yes	Yes	Yes
DRC10a1-*xmz	450	1,0L	No	Yes	Yes	Yes	Yes
DRC12a-*xmz	400	1,2L	No	Yes	Yes	Yes	Yes
DRC12a1-*xmz	450	1,2L	No	Yes	Yes	Yes	Yes
DRC15a-*xmz	500	1,5L	No	Yes	Yes	Yes	Yes
DRC15a1-*xmz	550	1,5L	No	Yes	Yes	Yes	Yes
DRC18a-*xmz	700	1,8L	No	Yes	Yes	Yes	Yes
DRC18a1-*xmz	650	1,8L	No	Yes	Yes	Yes	Yes
DRC22a-*xmz	900	2,2L	No	Yes	Yes	Yes	Yes
DRC22a1-*xmz	850	2,2L	No	Yes	Yes	Yes	Yes
DRC28a-*xmz	1100	2,8L	No	Yes	Yes	Yes	Yes
DRC28a1-*xmz	1000	2,8L	No	Yes	Yes	Yes	Yes
DRC28a2-*xmz	950	2,8L	No	Yes	Yes	Yes	Yes
DRC32a-*xmz	1200	3,2L	No	Yes	Yes	Yes	Yes
DRC32a1-*xmz	1250	3,2L	No	Yes	Yes	Yes	Yes
DRC36a-*xmz	1300	3,6L	No	Yes	Yes	Yes	Yes
DRC36a1-*xmz	1250	3,6L	No	Yes	Yes	Yes	Yes

a = C or S, indicates difference bottom enclosure. C means metal enclosure. S means plastic enclosure.
 * = A to P, a to y, indicates difference control panel, shown as below.

x = V, W or P, indicates difference pattern of the appearance. V means stainless steel. W means coated steel. P means coated steel with painted pattern.

y = X or Y, indicates difference connection. X means the appliance was with appliance inlet. Y means the appliance was type Y attachment.

m = A to O, indicates difference handle. Detail shown in below.

z = 1, 2 or 3, indicates difference electric circuit. Detail shown in attachment 3.

No keep warm function for models RC03-y.

Detail for different handle:

A	B	C	D	E	F
G	H	I	J	K	L
M	N	O	--	--	--
			--	--	--

Detail for different control panel:

A	B	C	D	E	F
G	H	I	J	K	L
M	N	O	P	a	b
c	d	e	f	g	h
i	j	k	l	m	n
o	p	q	r	s	t
u	v	w	x	y	--
					--

IEC 60335-2-15			
Clause	Requirement + Test	Result - Remark	Verdict
5	GENERAL CONDITIONS FOR THE TESTS		--
	Tests performed according to Clause 5, e.g. nature of supply, sequence of testing, etc.		P
5.2	If the test of 15.101 has to be carried out, three additional samples are required (IEC 60335-2-15)		N/A
5.3	Test of 19.101, carried out after the other tests (IEC 60335-2-15)		N/A
5.10	A class III construction part of the appliance is tested connected to its detachable power supply part taking into account the instructions provided with the appliance		N/A
5.101	Induction rice cookers tested as motor-operated appliances (IEC 60335-2-15)		N/A
6	CLASSIFICATION		--
6.1	Protection against electric shock: Class 0, 0I, I, II, III	Class I	P
	For a class III construction with a detachable power supply part the appliance is classified according to the detachable power supply part		N/A
6.2	Protection against harmful ingress of water		N/A
	Wash boilers and livestock feed boilers at least IPX3 (IEC 60335-2-15)		N/A
7	MARKING AND INSTRUCTIONS		--
7.1	Rated voltage or voltage range (V)	220-240 V	P
	Symbol for nature of supply, or	~	P
	Rated frequency (Hz)	50 Hz / 60 Hz	P
	Rated power input (W), or	See page 6 and 7	P
	Rated current (A)		N/A
	Manufacturer's or responsible vendor's name, trademark or identification mark		P
	Model or type reference	See page 6 and 7	P
	Symbol IEC 60417-5172, for class II appliances		N/A
	IP number, other than IPX0		N/A
	Symbol IEC 60417-5180 (2003-02), for class III appliances, unless		N/A
	the appliance is operated by batteries only, or		N/A
	for appliances powered by rechargeable batteries recharged in the appliance		N/A
	Symbol IEC 60417-5018, for class II and class III appliances incorporating a functional earth		N/A

IEC 60335-2-15			
Clause	Requirement + Test	Result - Remark	Verdict
	Symbol IEC 60417-5036, for the enclosure of electrically-operated water valves in external hose-sets for connection of an appliance to the water mains, if the working voltage exceeds extra-low voltage		N/A
	Appliances intended to be partially immersed in water for cleaning, marked with the maximum level of immersion, and (IEC 60335-2-15)		N/A
	with the substance of the following: "Do not immerse beyond this level" (IEC 60335-2-15)		N/A
	For kettles: level mark or other means which indicate the rated capacity, unless (IEC 60335-2-15)		N/A
	they cannot be filled beyond their rated capacity (IEC 60335-2-15)		N/A
	Indication visible whit kettle in filling position (IEC 60335-2-15)		N/A
	Reference to the level mark on the outside of the kettle, if the level is not self-evident (IEC 60335-2-15)		N/A
	Marking on the appliance of the closed position of the lid of pressure cooker, if it is not obvious (IEC 60335-2-15)		N/A
	Identification mark and model or type reference of stand for cordless kettles (IEC 60335-2-15)		N/A
	Soy milk makers: level mark or other means to indicate when they are filled to rated capacity, unless (IEC 60335-2-15)		N/A
	they cannot be filled beyond their rated capacity (IEC 60335-2-15)		N/A
7.2	Warning for stationary appliances for multiple supply		P
	Warning placed in vicinity of terminal cover		P
7.3	Range of rated values marked with the lower and upper limits separated by a hyphen	220-240 V	P
	Different rated values marked with the values separated by an oblique stroke		N/A
7.4	Appliances adjustable for different rated voltages or rated frequencies, the voltage or the frequency setting is clearly discernible		N/A
	Requirement met if frequent changes are not required and the rated voltage or rated frequency to which the appliance is to be adjusted is determined from a wiring diagram		N/A

IEC 60335-2-15			
Clause	Requirement + Test	Result - Remark	Verdict
7.5	Appliances with more than one rated voltage or one or more rated voltage ranges, marked with rated input or rated current for each rated voltage or range, unless		N/A
	the power input or current are related to the arithmetic mean value of the rated voltage range		P
	Relation between marking for upper and lower limits of rated power input or rated current and voltage is clear		N/A
7.6	Correct symbols used		P
	Symbol for nature of supply placed next to rated voltage		P
	Symbol for class II appliances placed unlikely to be confused with other marking		N/A
	Units of physical quantities and their symbols according to international standardized system		P
7.7	Connection diagram fixed to appliances to be connected to more than two supply conductors and appliances for multiple supply, unless		N/A
	correct mode of connection is obvious		N/A
7.8	Except for type Z attachment, terminals for connection to the supply mains indicated as follows:		--
	- marking of terminals exclusively for the neutral conductor (letter N)		N/A
	- marking of protective earthing terminals (symbol IEC 60417-5019)		P
	- marking of functional earthing terminals (symbol IEC 60417-5018)		N/A
	- marking not placed on removable parts		P
7.9	Marking or placing of switches which may cause a hazard		P
7.10	Indications of switches on stationary appliances and controls on all appliances by use of figures, letters or other visual means	See photo attachment for details	P
	This applies also to switches which are part of a control		P
	If figures are used, the off position indicated by the figure 0		N/A
	The figure 0 indicates only OFF position, unless no confusion with the OFF position		N/A
7.11	Indication for direction of adjustment of controls		N/A
7.12	Instructions for safe use provided		P
	Details concerning precautions during user maintenance		P

IEC 60335-2-15			
Clause	Requirement + Test	Result - Remark	Verdict
	The instructions state that:		--
	- the appliance is not to be used by persons (including children) with reduced physical, sensory or mental capabilities, or lack of experience and knowledge, unless they have been given supervision or instruction		P
	- children being supervised not to play with the appliance		P
	For a part of class III construction supplied from a detachable power supply unit, the instructions state that the appliance is only to be used with the unit provided		N/A
	Instructions for class III appliances state that it must only be supplied at SELV, unless		N/A
	it is a battery-operated appliance, the battery being charged outside the appliance		N/A
	For appliances for altitudes exceeding 2000 m, the maximum altitude is stated..... :		N/A
	The instructions for appliances incorporating a functional earth states that the appliance incorporates an earth connection for functional purposes only		N/A
	The instructions for appliances include the substance of the following: (IEC 60335-2-15)		--
	This appliance is intended to be used in household and similar applications such as: (IEC 60335-2-15)		P
	- staff kitchen areas in shops, offices and other working environments;		P
	- farm houses;		P
	- by clients in hotels, motels and other residential type environments;		P
	- bed and breakfast type environments		P
	If the manufacturer wants to limit the use of the appliance to less than the above, this is clearly stated in the instructions (IEC 60335-2-15)		N/A
	Appliance incorporating an appliance inlet and intended to be immersed for cleaning, instructions include the following: (IEC 60335-2-15)		--
	- the connector must be remove before cleaning;		N/A

IEC 60335-2-15			
Clause	Requirement + Test	Result - Remark	Verdict
	- the appliance inlet must be dried before the appliance is used again		N/A
	The instructions for appliances normally cleaned after use and not intended to be immersed in water for cleaning, state that the appliance must not be immersed (IEC 60335-2-15)		P
	This requirement normally applies to coffee-makers, cooking pans, milk heaters, pressure cookers, steam cookers, slow cookers, soy milk makers and yoghurt makers (IEC 60335-2-15)		N/A
	The instructions for use for appliances intended to be used with a connector incorporating a thermostat, state that only the appropriate connector must be used (IEC 60335-2-15)		N/A
	Unless, kettles are constructed so that a hazard cannot arise from boiling water being ejected, the instructions for use include the following: (IEC 60335-2-15)		--
	- if the kettle is overfilled, boiling water may be ejected		N/A
	The instructions for use for kettles filled through a lid aperture which is situated below the handle, include the substance of the following: (IEC 60335-2-15)		--
	- WARNING: "Do not remove the lid while the water is boiling"		N/A
	- WARNING: "Position the lid so that steam is directed away from the handle"		N/A
	The caution statement is not required if the lid can only be closed so that steam is directed away from the handle (IEC 60335-2-15)		N/A
	The instructions for cordless appliances state that the appliance is only to be used with the stand provided (IEC 60335-2-15)		N/A
	If the appliance and stand of cordless appliances can be lifted together by gripping the handle of the appliance, the instructions include the substance of the following: (IEC 60335-2-15)		--
	- CAUTION: Insure that the appliance is switched off before removing it from its stand		N/A
	Instructions for feeding bottle heaters: (IEC 60335-2-15)		--
	- state that the food should not be heated for too long a period;		N/A
	- state how to check that the correct food temperature has not been exceeded		N/A
	Instructions for pressure cookers, other than dynamic pressure cookers: (IEC 60335-2-15)		--
	- state that the ducts in the pressure regulator allowing the escape of steam should be checked regularly to ensure that they are not blocked		N/A

IEC 60335-2-15			
Clause	Requirement + Test	Result - Remark	Verdict
	Instructions for pressure cookers: (IEC 60335-2-15)		--
	- give details of how to open the container safely;		N/A
	- and state that the container must not be opened until the pressure has decreased sufficiently		N/A
	The instructions for use for egg boilers provided with a pricking device contain the substance of the following: (IEC 60335-2-15)		--
	- CAUTION: "Avoid injuries from the egg pricking device"		N/A
	Instructions for espresso coffee-makers incorporating a pressurized reservoir filled by the user: (IEC 60335-2-15)		--
	- contain information for the safe refilling of the water reservoir and the substance of the following:		N/A
	- WARNING: The filling aperture must not be opened during use		N/A
	The instructions for all appliances include: (IEC 60335-2-15)		--
	- a warning to avoid spillage on the connector;		P
	- details on how to clean the surfaces in contact with food;		P
	- a warning of potential injury from misuse;		P
	- a statement that the heating element surface is subject to residual heat after use		P
	The instructions for soy milk makers also include a statement that care shall be taken when handling the sharp cutting blades, emptying the container and during cleaning (IEC 60335-2-15)		N/A
	The instruction for soy milk makers incorporating a switch necessary for compliance with 22.40 include the substance of the following: (IEC 60335-2-15)		--
	- Switch off the appliance and disconnect from supply before changing accessories or approaching parts that move in use		N/A
	The instructions for coffee-makers other than built-in coffee-makers or those tested in a cabinet, shall state that the coffee-maker shall not be placed in a cabinet when in use (IEC 60335-2-15, AMD1)		N/A
	For coffee-makers having an additional decorative door, and for coffee-makers intended to be used in a cabinet, the instructions shall state that the coffee-maker must be operated with the decorative door open or the cabinet door open (IEC 60335-2-15, AMD1)		N/A
	The instructions for coffee-makers having surfaces of glass, ceramic or similar material that forms part of the enclosure of live parts shall include the substance of the following: (IEC 60335-2-15, AMD1)		--

IEC 60335-2-15			
Clause	Requirement + Test	Result - Remark	Verdict
	WARNING: Do not use the appliance if the surface is cracked		N/A
	The instructions for coffee-makers shall state that cleaning and user maintenance shall not be made by children without supervision (IEC 60335-2-15, AMD1)		N/A
7.12.1	Sufficient details for installation supplied		N/A
	For an appliance intended to be permanently connected to the water mains and not connected by a hose-set, this is stated		N/A
	If different rated voltages or different rated frequencies are marked, the instructions state what action to be taken to adjust the appliance		N/A
7.12.2	Stationary appliances not fitted with means for disconnection from the supply mains having a contact separation in all poles that provide full disconnection under overvoltage category III, the instructions state that means for disconnection must be incorporated in the fixed wiring in accordance with the wiring rules		N/A
7.12.3	Insulation of the fixed wiring in contact with parts exceeding 50 K during Clause 11; instructions state that the fixed wiring must be protected		N/A
7.12.4	Instructions for built-in appliances:		--
	- dimensions of space;		N/A
	- dimensions and position of supporting and fixing;		N/A
	- minimum distances between parts and surrounding structure;		N/A
	- minimum dimensions of ventilating openings and arrangement;		N/A
	- connection to supply mains and interconnection of separate components;		N/A
	- allow disconnection of the appliance after installation, by accessible plug or a switch in the fixed wiring, unless		N/A
	a switch complying with 24.3		N/A
	For coffee-makers suitable for operation when placed in a cabinet, the minimum dimensions of the cabinet shall be given (IEC 60335-2-15, AMD1)		N/A
7.12.5	Replacement cord instructions, type X attachment with a specially prepared cord		N/A
	Replacement cord instructions, type Y attachment		P
	Replacement cord instructions, type Z attachment		N/A

IEC 60335-2-15			
Clause	Requirement + Test	Result - Remark	Verdict
7.12.6	Caution in the instructions for appliances incorporating a non-self-resetting thermal cut-out that is reset by disconnection of the supply mains, if this cut-out is required to comply with the standard		N/A
7.12.7	Instructions for fixed appliances stating how the appliance is to be fixed		N/A
7.12.8	Instructions for appliances connected to the water mains:		--
	- max. inlet water pressure (Pa) :		N/A
	- min. inlet water pressure, if necessary (Pa)..... :		N/A
	Instructions concerning new and old hose-sets for appliances connected to the water mains by detachable hose-sets		N/A
7.12.9	Instructions specified in 7.12 and from 7.12.1 to 7.12.8 appear together before any other instructions supplied with the appliance		P
	These instructions may be supplied with the appliance separately from any functional use booklet		N/A
	They may follow the description of the appliance that identifies parts, or follow the drawings/sketches common to the languages of the instructions		N/A
	In addition, instructions are also available in an alternative format such as on a website or in a format such as a DVD :		P
7.13	Instructions and other texts in an official language		P
7.14	Marking clearly legible and durable, rubbing test as specified		P
	Signal words WARNING, CAUTION, DANGER in uppercase having a height as specified :		N/A
	Uppercase letter of the text explaining the signal word not smaller than 1,6 mm		N/A
	Moulded in, engraved, or stamped markings either raised above or have a depth below the surface of at least 0,25 mm, unless		N/A
	contrasting colours are used		N/A
	Markings checked by inspection, measurement and rubbing test as specified		P
7.15	Markings on a main part		P
	Marking clearly discernible from the outside, if necessary after removal of a cover	Outside	P
	For portable appliances, cover can be removed or opened without a tool		N/A

IEC 60335-2-15			
Clause	Requirement + Test	Result - Remark	Verdict
	For stationary appliances, name, trademark or identification mark and model or type reference visible after installation		N/A
	For fixed appliances, name, trademark or identification mark and model or type reference visible after installation according to the instructions		N/A
	Indications for switches and controls placed on or near the components. Marking not on parts which can be positioned or repositioned in such a way that the marking is misleading		P
	The symbol IEC 60417-5018 placed next to the symbol IEC 60417-5172 or IEC 60417-5180		N/A
7.16	Marking of a possible replaceable thermal link or fuse link clearly visible with regard to replacing the link		N/A
8	PROTECTION AGAINST ACCESS TO LIVE PARTS		--
8.1	Adequate protection against accidental contact with live parts		P
8.1.1	Requirement applies for all positions, detachable parts removed		P
	Lamps behind a detachable cover not removed, if conditions met		N/A
	Insertion or removal of lamps, protection against contact with live parts of the lamp cap		N/A
	Use of test probe B of IEC 61032, with a force not exceeding 1 N: no contact with live parts		P
	Use of test probe B of IEC 61032 through openings, with a force of 20 N: no contact with live parts		P
8.1.2	Use of test probe 13 of IEC 61032, with a force not exceeding 1 N, through openings in class 0 appliances and class II appliances/constructions: no contact with live parts		P
	Test probe 13 also applied through openings in earthed metal enclosures having a non-conductive coating: no contact with live parts		N/A
	See Note 101 (IEC 60335-2-15)		N/A
8.1.3	For appliances other than class II, use of test probe 41 of IEC 61032, with a force not exceeding 1 N: no contact with live parts of visible glowing heating elements		N/A
	For a single switching action obtained by a switching device, requirements as specified		N/A

IEC 60335-2-15			
Clause	Requirement + Test	Result - Remark	Verdict
	For appliances with a supply cord and without a switching device, the single switching action may be obtained by the withdrawal of the plug from a socket-outlet		N/A
8.1.4	Accessible part not considered live if:		--
	- safety extra-low a.c. voltage: peak value not exceeding 42,4 V;		N/A
	- safety extra-low d.c. voltage: not exceeding 42,4 V;		N/A
	- or separated from live parts by protective impedance		N/A
	If protective impedance: d.c. current not exceeding 2 mA, and		N/A
	a.c. peak value not exceeding 0,7 mA		N/A
	- for peak values over 42,4 V up to and including 450 V, capacitance not exceeding 0,1 μ F;		N/A
	- for peak values over 450 V up to and including 15 kV, discharge not exceeding 45 μ C;		N/A
	- for peak values over 15 kV, the energy in the discharge not exceeding 350 mJ		N/A
8.1.5	Live parts protected at least by basic insulation before installation or assembly:		--
	- built-in appliances;		N/A
	- fixed appliances;		N/A
	- appliances delivered in separate units		N/A
8.2	Class II appliances and constructions constructed so that there is adequate protection against accidental contact with basic insulation and metal parts separated from live parts by basic insulation only		P
	Only possible to touch parts separated from live parts by double or reinforced insulation		P
9	STARTING OF MOTOR-OPERATED APPLIANCES		--
	Requirements and tests are specified in part 2 when necessary		N/A
10	POWER INPUT AND CURRENT		--
10.1	Power input at normal operating temperature, rated voltage and normal operation not deviating from rated power input by more than shown in Table 1.:	(see appended table)	P

IEC 60335-2-15			
Clause	Requirement + Test	Result - Remark	Verdict
	If the power input varies throughout the operating cycle and the maximum value of the power input exceeds, by a factor greater than two, the arithmetic mean value of the power input occurring during a representative period, the power input is the maximum value that is exceeded for more than 10 % of the representative period		N/A
	Otherwise the power input is the arithmetic mean value		N/A
	Test carried out at upper and lower limits of the ranges for appliances with one or more rated voltage ranges, unless		N/A
	the rated power input is related to the arithmetic mean value		P
	The power input of automatic coffee-makers is measured during one operating cycle that is selectable by the user, such as cleaning, descaling, or selecting a beverage. The measurement starts with the appliance at room ambient temperature (IEC 60335-2-15, AMD1)		N/A
	The operating cycle starts with the activation by the user and ends when the appliance stops the cycle automatically and the next operating cycle can be started by the user (IEC 60335-2-15, AMD1)		N/A
10.2	Current at normal operating temperature, rated voltage and normal operation not deviating from rated current by more than shown in Table 2..... :		N/A
	If the current varies throughout the operating cycle and the maximum value of the current exceeds, by a factor greater than two, the arithmetic mean value of the current occurring during a representative period, the current is the maximum value that is exceeded for more than 10 % of the representative period		N/A
	Otherwise the current is the arithmetic mean value		N/A
	Test carried out at upper and lower limits of the ranges for appliances with one or more rated voltage ranges, unless		N/A
	the rated current is related to the arithmetic mean value of the range		N/A
	The input current of automatic coffee-makers is measured during one operating cycle that is selectable by the user, such as cleaning, descaling, or selecting a beverage. The measurement starts with the appliance at room ambient temperature (IEC 60335-2-15, AMD1)		N/A

IEC 60335-2-15			
Clause	Requirement + Test	Result - Remark	Verdict
	The operating cycle starts with the activation by the user and ends when the appliance stops the cycle automatically and the next operating cycle can be started by the user (IEC 60335-2-15, AMD1)		N/A
11	HEATING		--
11.1	No excessive temperatures in normal use		P
11.2	The appliance is held, placed or fixed in position as described	On horizontal support	P
	Portable appliances tested away from the walls of the test corner (IEC 60335-2-15)		P
	Coffee-makers with a decorative door or intended to be used in a cabinet shall be tested with the door open (IEC 60335-2-15, AMD1)		N/A
11.3	Temperature rises, other than of windings, determined by thermocouples		P
	Temperature rises of windings determined by resistance method, unless		N/A
	the windings are non-uniform or it is difficult to make the necessary connections		P
	See Note 101 (IEC 60335-2-15)		N/A
11.4	Heating appliances operated under normal operation at 1,15 times rated power input (W) :		P
	If the temperature rise limits are exceeded in appliances incorporating motors, transformers or electronic circuits and if the power input is lower than the rated power input, test repeated with the appliance supplied at 1,06 times rated voltage (IEC 60335-2-15)		N/A
	Appliances with electronic power controls are operated as combined appliances (IEC 60335-2-15, AMD1)		N/A
11.5	Motor-operated appliances operated under normal operation at most unfavourable voltage between 0,94 and 1,06 times rated voltage (V)		N/A
11.6	Combined appliances operated under normal operation at most unfavourable voltage between 0,94 and 1,06 times rated voltage (V)		N/A
	Combined appliances tested as heating appliances (IEC 60335-2-15)		N/A
11.7	Appliances operated for the duration specified in 11.7.101 to 11.7.106 (IEC 60335-2-15)		P
11.7.101	For kettles with temperature limiter: test terminated after second operation of temperature limiter (IEC 60335-2-15)		N/A

IEC 60335-2-15			
Clause	Requirement + Test	Result - Remark	Verdict
	For kettles with thermostat: test terminated 15 min after the water has attained 95 °C		N/A
	For other kettles: test terminated 5 min after the water has attained 95 °C		N/A
11.7.102	For cooking pans, egg boilers, feeding-bottle heaters, glue pots, livestock feed boilers, milk heaters, sterilizers, wash boilers and for appliances that boil water other than kettles, the test is terminated: (IEC 60335-2-15)		--
	- appliances without a thermal control: 15 min after the water in the container has attained a temperature of 95 °C or the maximum temperature it can attain if this is lower		N/A
	- portable appliances provided with a thermal control: 15 min after the thermal control has operated for the first time		N/A
	- fixed appliances provided with a thermal control: 30 min after the thermal control has operated for the first time		N/A
	- appliances with acoustic signal: 1 min after signal		N/A
	- egg boilers having provision for keeping eggs warm, and appliances having a heated surface intended to keep liquid warm: when steady conditions are established		N/A
11.7.103	Slow cookers, rice cookers, steam cookers and yoghurt makers operated until steady conditions are established (IEC 60335-2-15)		P
	Slow cookers pre-warmed in the dry state if this instruction is given		N/A
11.7.104	For espresso coffee-makers, the brewing period is followed by a rest period of 1 min or the period stated in the instructions, if this is longer. The water container is refilled during the rest periods (IEC 60335-2-15, AMD1)		N/A
	For automatic espresso coffee makers and espresso coffee makers, the brewing period is the time necessary to produce the maximum quantity of coffee allowed by the timer or by the capacity of the coffee pot		N/A
	For manual espresso coffee makers, maximum quantity of coffee to be produced specified in the instructions, or		N/A
	the brewing period is the time necessary to produce 100 ml of coffee for each cycle		N/A
	For espresso coffee-makers having an outlet for supplying steam or hot water, the brewing period is immediately followed by a period during which the steam or water is supplied for the time stated in the instructions, or		N/A

IEC 60335-2-15			
Clause	Requirement + Test	Result - Remark	Verdict
	- for espresso coffee makers having an outlet for supplying steam, 1 min;		N/A
	- for espresso coffee makers having an outlet for supplying water, the time necessary to produce 100 ml of water		N/A
	- for espresso coffee-makers having an outlet for supplying steam and an outlet for supplying hot water, 1 min period supplying steam is followed by time necessary to produce 100 ml of water (IEC 60335-2-15, AMD1)		N/A
	Espresso coffee-makers operated until steady conditions are established		N/A
	Other coffee-makers operated for the time necessary to make the maximum quantity of coffee stated in the instructions		N/A
	The container refilled as quickly as possible and the coffee-maker operated again until steady conditions are established		N/A
11.7.105	Pressure cookers operated 15 min after attaining the maximum cooking pressure (IEC 60335-2-15)		N/A
11.7.106	Soy milk makers operated for a complete operating cycle (IEC 60335-2-15)		N/A
11.8	Temperature rises monitored continuously and not exceeding the values in Table 3	(see appended table)	P
	If the temperature rise of a motor winding exceeds the value of Table 3, or		N/A
	if there is doubt with regard to classification of insulation,		N/A
	tests of Annex C are carried out		N/A
	Sealing compound does not flow out		P
	Protective devices do not operate, except		P
	components in protective electronic circuits tested for the number of cycles specified in 24.1.4		N/A
	When an appliance connector incorporates a thermostat, the temperature rise limit for the pins of the inlet does not apply (IEC 60335-2-15)		N/A
	The temperature rise limits of motors, transformers, components of electronic circuit and parts directly influenced by them may be exceeded when the appliance is operated at 1,15 times rated power input (IEC 60335-2-15)		N/A
13	LEAKAGE CURRENT AND ELECTRIC STRENGTH AT OPERATING TEMPERATURE		--
13.1	Leakage current not excessive and electric strength adequate		P

IEC 60335-2-15			
Clause	Requirement + Test	Result - Remark	Verdict
	Heating appliances operated at 1,15 times the rated power input (W)..... :		P
	Motor-operated appliances and combined appliances supplied at 1,06 times the rated voltage (V)..... :		N/A
	Protective impedance and radio interference filters disconnected before carrying out the tests		P
13.2	The leakage current is measured by means of the circuit described in Figure 4 of IEC 60990:1999		P
	For class 0I appliances and class I appliances, except parts of class II construction, C may be replaced by a low impedance ammeter		P
	Leakage current measurements..... :	(see appended table)	P
13.3	The appliance is disconnected from the supply		P
	Electric strength tests according to Table 4 :	(see appended table)	P
	No breakdown during the tests		P
14	TRANSIENT OVERVOLTAGES		--
	Appliances withstand the transient over-voltages to which they may be subjected		N/A
	Clearances having a value less than specified in Table 16 subjected to an impulse voltage test, the test voltage specified in Table 6..... :		N/A
	No flashover during the test, unless		N/A
	of functional insulation if the appliance complies with Clause 19 with the clearance short-circuited		N/A
15	MOISTURE RESISTANCE		--
15.1	Enclosure provides the degree of moisture protection according to classification of the appliance	IPX0	P
	Compliance checked as specified in 15.1.1, taking into account 15.1.2, followed by the electric strength test of 16.3		N/A
	No trace of water on insulation which can result in a reduction of clearances or creepage distances below values specified in Clause 29		N/A
15.1.1	Appliances, other than IPX0, subjected to tests as specified in IEC 60529..... :		N/A
	Water valves containing live parts in external hoses for connection of an appliance to the water mains tested as specified for IPX7 appliances		N/A
15.1.2	Hand-held appliance turned continuously through the most unfavourable positions during the test		N/A
	Built-in appliances installed according to the instructions		N/A

IEC 60335-2-15			
Clause	Requirement + Test	Result - Remark	Verdict
	Appliances placed or used on the floor or table placed on a horizontal unperforated support		N/A
	Appliances normally fixed to a wall and appliances with pins for insertion into socket-outlets are mounted on a wooden board		N/A
	For IPX3 appliances, the base of wall mounted appliances is placed at the same level as the pivot axis of the oscillating tube		N/A
	For IPX4 appliances, the horizontal centre line of the appliance is aligned with the pivot axis of the oscillating tube, and		N/A
	for appliances normally used on the floor or table, the movement is limited to two times 90° for a period of 5 min, the support being placed at the level of the pivot axis of the oscillating tube		N/A
	Wall-mounted appliances, take into account the distance to the floor stated in the instructions		N/A
	Appliances normally fixed to a ceiling are mounted underneath a horizontal unperforated support, the pivot axis of the oscillating tube located at the level of the underside of the support, and		N/A
	for IPX4 appliances, the movement of the tube is limited to two times 90° from the vertical for a period of 5 min		N/A
	Appliances with type X attachment fitted with a flexible cord as described		N/A
	Detachable parts subjected to the relevant treatment with the main part		N/A
	However, if a part has to be removed for user maintenance and a tool is needed, this part is not removed		N/A
15.2	Spillage of liquid does not affect the electrical insulation		P
	Spillage solution comprising water containing approximately 1 % NaCl and 0,6 % rinsing agent		P
	Appliances with type X attachment fitted with a flexible cord as described		N/A
	Appliances incorporating an appliance inlet tested with or without an connector, whichever is most unfavourable		N/A
	Detachable parts are removed		P
	Overfilling test with additional amount of the solution, over a period of 1 min (I)..... :		P
	The appliance withstands the electric strength test of 16.3		P

IEC 60335-2-15			
Clause	Requirement + Test	Result - Remark	Verdict
	No trace of water on insulation that can result in a reduction of clearances or creepage distances below values specified in Clause 29		P
	The test is only carried out with the appliance connector in position (IEC 60335-2-15)		P
	In case of doubt, spillage tests carried out with the appliance deviating from the normal position by an angle not exceeding 5° (IEC 60335-2-15)		P
	Kettles that can be filled through the spout: additional overflowing test in conditions as specified (IEC 60335-2-15)		N/A
	For cordless appliances, the test with the appliance on the horizontal plane carried out with the appliance both on and off its stand (IEC 60335-2-15)		N/A
	For cordless kettles, the additional test carried out only with the cordless kettle off its stand, the kettle being replaced on its stand in order to carry out the electric strength test of 16.3 (IEC 60335-2-15)		N/A
	Coffee makers provided with a removable coffee pot: particular overflowing test in conditions as specified (IEC 60335-2-15)		N/A
	Steam sterilizers: particular overflowing test in conditions as specified (IEC 60335-2-15)		N/A
	For rice cookers, the test carried out with the rice container in place (IEC 60335-2-15)		P
	Coffee-makers dispensing liquid into a serving container, such as a cup or jug, are tested by steadily pouring 0,5 l of the solution over the surface where the container is filled or the container is transported and removed by the user. If a drop container is placed beneath this surface, the drop container is completely filled before the test is carried out (IEC 60335-2-15, AMD1)		N/A
	Coffee-makers having external surfaces on which it is possible to place a vessel, such as a cup or jug, are tested by pouring 0,2 l of the solution over the complete depositing area in approximately 5 s (IEC 60335-2-15, AMD1)		N/A
	For coffee makers, after each overflowing test or application of liquid, all residues are then removed and the appliance is dried (IEC 60335-2-15, AMD1)		N/A
15.3	Appliances proof against humid conditions		P
	Checked by test Cab: Damp heat steady state in IEC 60068-2-78		P
	Detachable parts removed and subjected, if necessary, to the humidity test with the main part		P

IEC 60335-2-15			
Clause	Requirement + Test	Result - Remark	Verdict
	Humidity test for 48 h in a humidity cabinet		P
	Reassembly of those parts that may have been removed		P
	The appliance withstands the tests of Clause 16		P
15.101	Appliances to be partially or completely immersed in water for cleaning sufficiently protected against effects of immersion (IEC 60335-2-15)		N/A
	Compliance is checked by the tests as specified, which are carried out on three additional appliances		N/A
	No trace of water on insulation which can result in reduction of creepage distances and clearance below values specified in 29		N/A
15.102	Connecting device of stands for cordless kettles not affected by water: particular electric strength test in conditions as specified (IEC 60335-2-15)		N/A
	Compliance is checked by the test in conditions as specified		N/A
	Stand withstanding the test of 16.3 with voltage reduced to 2500 V for reinforced insulation		N/A
15.103	Interior of rice cookers not affected by water (IEC 60335-2-15)		P
	Compliance is checked by the test as specified		P
	Rice cookers withstanding the electric strength test of 16.3		P

IEC 60335-2-15			
Clause	Requirement + Test	Result - Remark	Verdict
16	LEAKAGE CURRENT AND ELECTRIC STRENGTH		--
16.1	Leakage current not excessive and electric strength adequate		P
	Protective impedance disconnected from live parts before carrying out the tests		N/A
	Tests carried out at room temperature and not connected to the supply		P
16.2	Single-phase appliances: test voltage 1,06 times rated voltage (V)..... :	254,4 V	P
	Three-phase appliances: test voltage 1,06 times rated voltage divided by $\sqrt{3}$ (V)..... :		N/A
	Leakage current measurements..... :	(see appended table)	P
	Limit values doubled if:		--
	- all controls have an off position in all poles, or		N/A
	- the appliance has no control other than a thermal cut-out, or		N/A
	- all thermostats, temperature limiters and energy regulators do not have an off position, or		N/A
	- the appliance has radio interference filters		N/A
	With the radio interference filters disconnected, the leakage current do not exceed limits specified :		N/A
16.3	Electric strength tests according to Table 7 :	(see appended table)	P
	Test voltage applied between the supply cord and inlet bushing and cord guard and cord anchorage as specified:		P
	No breakdown during the tests		P
17	OVERLOAD PROTECTION OF TRANSFORMERS AND ASSOCIATED CIRCUITS		--
	No excessive temperatures in transformer or associated circuits in event of short-circuits likely to occur in normal use :		N/A
	Appliance supplied with 1,06 or 0,94 times rated voltage under the most unfavourable short-circuit or overload likely to occur in normal use (V) :		N/A
	Basic insulation is not short-circuited		N/A
	Temperature rise of insulation of the conductors of safety extra-low voltage circuits not exceeding the relevant value specified in Table 3 by more than 15 K		N/A
	Temperature of the winding not exceeding the value specified in Table 8		N/A

IEC 60335-2-15			
Clause	Requirement + Test	Result - Remark	Verdict
	However, limits do not apply to fail-safe transformers complying with Sub-clause 15.5 of IEC 61558-1		N/A
18	ENDURANCE		--
	Requirements and tests are specified in part 2 when necessary		N/A
19	ABNORMAL OPERATION		--
19.1	The risk of fire, mechanical damage or electric shock under abnormal or careless operation obviated		P
	Electronic circuits so designed and applied that a fault will not render the appliance unsafe		N/A
	Appliances incorporating heating elements subjected to the tests of 19.2 and 19.3, and		P
	if the appliance also has a control that limit the temperature during Clause 11 it is subjected to the test of 19.4, and		P
	if applicable, to the test of 19.5		P
	Appliances incorporating PTC heating elements are also subjected to the test of 19.6		N/A
	Appliances incorporating motors subjected to the tests of 19.7 to 19.10, as applicable		N/A
	Appliances incorporating electronic circuits subjected to the tests of 19.11 and 19.12, as applicable		P
	Appliances incorporating contactors or relays subjected to the test of 19.14, being carried out before the tests of 19.11		P
	Appliances incorporating voltage selector switches subjected to the test of 19.15		N/A
	Unless otherwise specified, the tests are continued until a non-self-resetting thermal cut-out operates, or		P
	until steady conditions are established		P
	If a heating element or intentionally weak part becomes open-circuited, the relevant test is repeated on a second sample		N/A
	Kettles are not subjected to the test of 19.2 (IEC 60335-2-15)		N/A
	Kettles also subjected to the test of 19.101, unless the appliance incorporates a non-self-resetting thermal cut-out, in order to comply with 19.4 (IEC 60335-2-15)		N/A

IEC 60335-2-15			
Clause	Requirement + Test	Result - Remark	Verdict
	Kettles for which compliance with 19.101 relies on the operation of a non-self-resetting thermal cut-out are subjected to the test of 19.102 (IEC 60335-2-15)		N/A
	For appliances with an external surface providing a keep warm function, the test of 19.106 applies (IEC 60335-2-15, AMD1)		N/A
	For coffee-makers having a decorative door, the test of 19.107 applies (IEC 60335-2-15, AMD1)		N/A
	For automatic coffee-makers of the coffee bean type, the tests of 19.108 applies (IEC 60335-2-15, AMD1)		N/A
19.2	Test of appliances with heating elements with restricted heat dissipation; test voltage (V), power input of 0,85 times rated power input (W) :	(see appended table)	P
	Appliances are placed as near as possible to the walls of the test corner (IEC 60335-2-15)		P
	They are tested empty with lids open or closed whichever is the more unfavourable (IEC 60335-2-15)		P
	Induction rice cookers operating under the conditions of Clause 11 with the rice container empty (IEC 60335-2-15)		N/A
19.3	Test of 19.2 repeated; test voltage (V), power input of 1,24 times rated power input (W) :	(see appended table)	P
	Kettles are operated empty at 1,15 times rated power input (IEC 60335-2-15)		N/A
	The test is carried out with the kettle filled with sufficient water to cover the heating element or if the heating element is not positioned inside the container, to a depth of 10 mm (IEC 60335-2-15)		N/A
19.4	Test conditions as in Clause 11, any control limiting the temperature during tests of Clause 11 short-circuited		P
	Pressure cookers: (IEC 60335-2-15)		--
	- all pressure regulating devices rendered inoperative; and		N/A
	- in other than dynamic pressure cookers, all protective devices that vent steam and intentionally weak parts that vent steam rendered inoperative; and		N/A
	- in dynamic pressure cookers, all protective devices, other than intentionally weak parts, that vent steam rendered inoperative		N/A

IEC 60335-2-15			
Clause	Requirement + Test	Result - Remark	Verdict
19.5	Test of 19.4 repeated on class 0I and I appliances with tubular sheathed or embedded heating elements. No short-circuiting, but one end of the element connected to the sheath		P
	The test repeated with reversed polarity and the other end of the heating element connected to the sheath		P
	The test is not carried out on appliances intended to be permanently connected to fixed wiring and on appliances where an all-pole disconnection occurs during the test of 19.4		N/A
19.6	Appliances with PTC heating elements tested at rated voltage, establishing steady conditions		N/A
	The working voltage of the PTC heating element is increased by 5 % and the appliance is operated until steady conditions are re-established. The voltage is then increased in similar steps until 1,5 times working voltage or until the PTC heating element ruptures (V)..... :		N/A
19.7	Stalling test by locking the rotor if the locked rotor torque is smaller than the full load torque, or		N/A
	locking moving parts of other appliances		N/A
	Locked rotor, capacitors open-circuited one at a time		N/A
	Test repeated with capacitors short-circuited one at a time, unless		N/A
	the capacitor is of class S2 or S3 of IEC 60252-1		N/A
	Appliances with timer or programmer supplied with rated voltage for each of the tests, for a period equal to the maximum period allowed..... :		N/A
	An electronic timer or programmer that operates to ensure compliance with the test before the maximum period under the conditions of Clause 11 is reached, is a protective electronic circuit		N/A
	Other appliances supplied with rated voltage for a period as specified		N/A
	Espresso coffee-makers incorporating a pump operated for a period of 5 min (IEC 60335-2-15)		N/A
	Soy milk makers operated for one cycle of operation (IEC 60335-2-15)		N/A
	Winding temperatures not exceeding values specified in Table 8		N/A
19.8	Multi-phase motors operated at rated voltage with one phase disconnected		N/A

IEC 60335-2-15			
Clause	Requirement + Test	Result - Remark	Verdict
19.9	Running overload test on appliances incorporating motors intended to be remotely or automatically controlled or liable to be operated continuously		N/A
	Motor-operated and combined appliances for which 30.2.3 is applicable and that use overload protective devices relying on electronic circuits to protect the motor windings, are also subjected to the test		N/A
	Winding temperatures not exceeding values as specified		N/A
19.10	Series motor operated at 1,3 times rated voltage for 1 min (V)		N/A
	During the test, parts not being ejected from the appliance		N/A
19.11	Electronic circuits, compliance checked by evaluation of the fault conditions specified in 19.11.2 for all circuits or parts of circuits, unless		N/A
	they comply with the conditions specified in 19.11.1		N/A
	Appliances incorporating an electronic circuit that relies upon a programmable component to function correctly, subjected to the test of 19.11.4.8, unless		N/A
	restarting does not result in a hazard		N/A
	Appliances having a device with an off position obtained by electronic disconnection, or a device placing the appliance in a stand-by mode, subjected to the tests of 19.11.4		N/A
	If the safety of the appliance under any of the fault conditions depends on the operation of a miniature fuse-link complying with IEC 60127, the test of 19.12 is carried out		N/A
	During and after each test the following is checked:		--
	- the temperature of the windings do not exceed the values specified in Table 8		N/A
	- the appliance complies with the conditions specified in 19.13		N/A
	- any current flowing through protective impedance not exceeding the limits specified in 8.1.4		N/A
	If a conductor of a printed board becomes open-circuited, the appliance is considered to have withstood the particular test, provided both of the following conditions are met:		--
	- the base material of the printed circuit board withstands the test of Annex E		N/A
	- any loosened conductor does not reduce clearance or creepage distances between live parts and accessible metal parts below the values specified in Clause 29		N/A

IEC 60335-2-15			
Clause	Requirement + Test	Result - Remark	Verdict
19.11.1	Fault conditions a) to g) in 19.11.2 are not applied to circuits or parts of circuits meeting both of the following conditions:		--
	- the electronic circuit is a low-power circuit, that is, the maximum power at low-power points does not exceed 15 W according to the tests specified		N/A
	- the protection against electric shock, fire hazard, mechanical hazard or dangerous malfunction of other parts of the appliance does not rely on the correct functioning of the electronic circuit		N/A
19.11.2	Fault conditions applied one at a time, the appliance operating under conditions specified in Clause 11, but supplied at rated voltage, duration of the tests as specified:		--
	a) short circuit of functional insulation if clearances or creepage distances are less than the values specified in Clause 29		N/A
	b) open circuit at the terminals of any component		N/A
	c) short circuit of capacitors, unless		N/A
	they comply with IEC 60384-14		N/A
	d) short circuit of any two terminals of an electronic component, other than integrated circuits		N/A
	This fault condition is not applied between the two circuits of an optocoupler		N/A
	e) failure of triacs in the diode mode		N/A
	f) failure of microprocessors and integrated circuits		N/A
	g) failure of an electronic power switching device		N/A
	Each low power circuit is short-circuited by connecting the low-power point to the pole of the supply source from which the measurements were made		N/A
19.11.3	If the appliance incorporates a protective electronic circuit that operates to ensure compliance with clause 19, the appliance is tested as specified		N/A
19.11.4	Appliances having a device with an off position obtained by electronic disconnection, or		N/A
	a device that can be placed in the stand-by mode,		N/A
	subjected to the tests of 19.11.4.1 to 19.11.4.7, the device being set in the off position or in the stand-by mode		N/A
	Appliances incorporating a protective electronic circuit subjected to the tests of 19.11.4.1 to 19.11.4.7, the tests being carried out after the protective electronic circuit has operated, except that		N/A

IEC 60335-2-15			
Clause	Requirement + Test	Result - Remark	Verdict
	appliances operated for 30 s or 5 min during the test of 19.7 are not subjected to the tests for electromagnetic phenomena		N/A
	Surge protective devices disconnected, unless		N/A
	they incorporate spark gaps		N/A
19.11.4.1	The appliance is subjected to electrostatic discharges in accordance with IEC 61000-4-2, test level 4		N/A
19.11.4.2	The appliance is subjected to radiated fields in accordance with IEC 61000-4-3, at frequency ranges specified		N/A
19.11.4.3	The appliance is subjected to fast transient bursts in accordance with IEC 61000-4-4, test level 3 or 4 as specified		N/A
19.11.4.4	The power supply terminals of the appliance subjected to voltage surges in accordance with IEC 61000-4-5, test level 3 or 4 as specified		N/A
	An open circuit test voltage of 2 kV is applicable for the line-to-line coupling mode		N/A
	An open circuit test voltage of 4 kV is applicable for the line-to-earth coupling		N/A
	Earthed heating elements in class I appliances disconnected		N/A
19.11.4.5	The appliance is subjected to injected currents in accordance with IEC 61000-4-6, test level 3		N/A
19.11.4.6	Appliances having a rated current not exceeding 16 A are subjected to the class 3 voltage dips and interruptions in accordance with IEC 61000-4-11		N/A
	Appliances having a rated current exceeding 16 A are subjected to the class 3 voltage dips and interruptions in accordance with IEC 61000-4-34		N/A
19.11.4.7	The appliance is subjected to mains signals in accordance with IEC 61000-4-13, test level class 2		N/A
19.11.4.8	The appliance is supplied at rated voltage and operated under normal operation. After 60 s the power supply is reduced to a level such that the appliance ceases to respond or parts controlled by the programmable component cease to operate		N/A
	The appliance continues to operate normally, or		N/A
	requires a manual operation to restart		N/A
19.12	If the safety of the appliance for any of the fault conditions specified in 19.11.2 depends on the operation of a miniature fuse-link complying with IEC 60127, the test is repeated, measuring the current flowing through the fuse-link; measured current (A); rated current of the fuse-link (A)..... :		N/A

IEC 60335-2-15			
Clause	Requirement + Test	Result - Remark	Verdict
19.13	During the tests the appliance does not emit flames, molten metal, poisonous or ignitable gas in hazardous amounts		P
	Temperature rises not exceeding the values shown in Table 9..... :	(see appended table)	P
	Compliance with Clause 8 not impaired		P
	If the appliance can still be operated it complies with 20.2		N/A
	Insulation, other than of class III appliances or class III constructions that do not contain live parts, withstands the electric strength test of 16.3, the test voltage as specified in Table 4:		--
	- basic insulation (V)..... :	1000	P
	- supplementary insulation (V)..... :		N/A
	- reinforced insulation (V)..... :	3000	P
	After operation or interruption of a control, clearances and creepage distances across the functional insulation withstand the electric strength test of 16.3, the test voltage being twice the working voltage		P
	The appliance does not undergo a dangerous malfunction, and		P
	no failure of protective electronic circuits, if the appliance is still operable		N/A
	Appliances tested with an electronic switch in the off position, or in the stand-by mode:		--
	- do not become operational, or		N/A
	- if they become operational, do not result in a dangerous malfunction during or after the tests of 19.11.4		N/A
	If the appliance contains lids or doors that are controlled by one or more interlocks, one of the interlocks may be released provided that:		--
	- the lid or door does not move automatically to an open position when the interlock is released, and		N/A
	- the appliance does not start after the cycle in which the interlock was released		N/A
	During the test of 19.4, protective devices of pressure cookers other than dynamic pressure cookers operate before pressure has reached 350 kPa (IEC 60335-2-15)		N/A
	During the test of 19.4, protective devices or intentionally weak parts of dynamic pressure cookers operate before pressure has reached 250 kPa (IEC 60335-2-15)		N/A

IEC 60335-2-15			
Clause	Requirement + Test	Result - Remark	Verdict
	Temperature rise of windings of induction rice cookers not exceeding the values specified in 19.7 (IEC 60335-2-15)		N/A
	Induction rice cookers: electric strength test carried out immediately after switching off the appliance (IEC 60335-2-15)		N/A
19.14	Appliances operated under the conditions of Clause 11, any contactor or relay contact operating under the conditions of Clause 11 being short-circuited		N/A
	For a relay or contactor with more than one contact, all contacts are short-circuited at the same time		N/A
	A relay or contactor operating only to ensure the appliance is energized for normal use is not short-circuited		N/A
	If more than one relay or contactor operates in Clause 11, they are short-circuited in turn		N/A
19.15	For appliances with a mains voltage selector switch, the switch is set to the lowest rated voltage position and the highest value of rated voltage is applied		N/A
19.101	Kettles operated empty at 0,85 times or 1,15 times rated power input, whichever is more unfavourable, with thermal cut-out that operates during the test of 19.4 short circuited (IEC 60335-2-15)		N/A
	During the test, any flames keep within the enclosure of the kettle and supporting surface does not ignite		N/A
	After the test, live parts not be accessible		N/A
19.102	Kettles are placed on a plywood board having a thickness of approximately 20 mm (IEC 60335-2-15, AMD1)		N/A
	Kettles incorporating two self-resetting thermal cut-outs operated with one of the thermal cut-out short circuited, empty at 0,85 or 1,15 times rated power input, whichever is most unfavourable (IEC 60335-2-15)		N/A
	Within 2 s of the thermal cut-out operating, the kettle is filled with water having a temperature of 15 °C ±5 °C. After 1 min, the kettle is emptied		N/A
	The test is carried out 100 times		N/A
19.103	Appliances with detachable liquid containers: automatic transfer of liquid from one container to another is liable and safe (IEC 60335-2-15)		N/A
	Compliance is checked by the test as specified		N/A
	After the test, the appliance withstands the tests of 16.3, and		N/A

IEC 60335-2-15			
Clause	Requirement + Test	Result - Remark	Verdict
	no trace of water on insulation which can result in reduction of creepage distances and clearances below values specified in Clause 29		N/A
19.104	The overloading of a soy milk maker does not result in a hazard (IEC 60335-2-15)		N/A
	Compliance is checked by the test as specified		N/A
	During the test, any flames keep within the enclosure and supporting surface does not ignite		N/A
	After the test, live parts not be accessible		N/A
19.105	When a soy milk maker is disconnected from the supply accidentally during normal use, it does not result in a hazard (IEC 60335-2-15)		N/A
	Compliance is checked by the test as specified		N/A
	During the test, any flames keep within the enclosure and supporting surface does not ignite		N/A
	After the test, live parts not be accessible		N/A
19.106	The appliance is operated at rated power input with the heated surface completely covered with two layers of textile material of pre-washed double-hemmed cotton sheets until steady conditions are established (IEC 60335-2-15, AMD1)		N/A
	If a thermostat operates, the test is repeated with the one-third of the heated surface furthest from the temperature-sensing element covered (IEC 60335-2-15, AMD1)		N/A
	The textile material shall not ignite (IEC 60335-2-15, AMD1)		N/A
19.107	Coffee-makers with a decorative door or intended to be used in a cabinet are operated under the conditions specified in Clause 11 but with the decorative door or cabinet door closed (IEC 60335-2-15, AMD1)		N/A
19.108	Automatic coffee-makers of the coffee bean type, other than automatic espresso coffee-makers of the coffee bean type, are supplied at rated voltage and operated under normal operation five times with rest periods (IEC 60335-2-15, AMD1)		N/A
	Automatic espresso coffee-makers of the coffee bean type are supplied at rated voltage and are set to maximum quantity of coffee powder, with smallest amount of coffee in the cup according to the instructions without rest periods (IEC 60335-2-15, AMD1)		N/A
	The duration of the operating period is (IEC 60335-2-15, AMD1)		--
	– for appliances incorporating a timer, the longest period allowed by the timer;		N/A

IEC 60335-2-15			
Clause	Requirement + Test	Result - Remark	Verdict
	– for other appliances, as follows:		N/A
	• for automatic coffee-makers incorporating coffee mills of the grinding type, 30 s longer than the time needed to fill the collecting container or the time required to empty the hopper, whichever is shorter;		N/A
	• for automatic coffee-makers incorporating other coffee mills, 1 min		N/A
	The duration of the rest period for is (IEC 60335-2-15, AMD1)		--
	– 10 s, for appliances provided with a collecting container;		N/A
	– 60 s, for other appliances		N/A
	The temperature of the windings shall not exceed the values shown in Table 8 (IEC 60335-2-15, AMD1)		N/A
20	STABILITY AND MECHANICAL HAZARDS		--
20.1	Appliances having adequate stability		P
	Tilting test through an angle of 10°, appliance placed on an inclined plane/horizontal support, not connected to the supply mains; appliance does not overturn		P
	Tilting test repeated on appliances with heating elements, angle of inclination increased to 15°		P
	Possible heating test in overturned position; temperature rise does not exceed values shown in Table 9		N/A
20.2	Moving parts adequately arranged or enclosed as to provide protection against personal injury		N/A
	Protective enclosures, guards and similar parts are non-detachable, and		N/A
	have adequate mechanical strength		N/A
	Enclosures that can be opened by overriding an interlock are considered to be detachable parts		N/A
	Self-resetting thermal cut-outs and overcurrent protective devices not causing a hazard by unexpected closure		N/A
	Not possible to touch dangerous moving parts with the test probe described		N/A
20.101	The container and cutting blades of soy milk makers have adequate mechanical strength (IEC 60335-2-15)		N/A
	Compliance is checked by the test as specified		N/A
	Container and cutting blades not broken		N/A

IEC 60335-2-15			
Clause	Requirement + Test	Result - Remark	Verdict
20.102	The rotating parts of soy milk makers not become loose during operation (IEC 60335-2-15)		N/A
	Compliance is checked by inspection and manual test as specified		N/A
	Fastening of screws and nuts in a direction opposite to the direction of rotation of the rotating parts considered to be a suitable means of securing the rotating parts		N/A
20.103	For soy milk makers: lid interlock, if any, constructed so that accidental operation of the appliance is prevented (IEC 60335-2-15)		N/A
	Lid interlock switches are biased-off switches		N/A
	If there is an interlock between the lid and the main switch, the lid is locked when the switch is in the on position		N/A
	When the lid is not correctly closed, the switch is locked in the off position		N/A
	Compliance is checked by inspection, by manual test and by applying test probe B of IEC 61032		N/A
21	MECHANICAL STRENGTH		--
21.1	Appliance has adequate mechanical strength and is constructed as to withstand rough handling		P
	Checked by applying 3 blows to every point of the enclosure like to be weak, in accordance with test Ehb of IEC 60068-2-75, spring hammer test, with an impact energy of 0,5 J	(see appended table)	P
	The appliance shows no damage impairing compliance with this standard, and		P
	compliance with 8.1, 15.1 and Clause 29 not impaired		P
	If doubt, supplementary or reinforced insulation subjected to the electric strength test of 16.3		N/A
	If necessary, repetition of groups of three blows on a new sample		N/A
	Breakage of glass parts is neglected provided that compliance with 8.1, 15.1 and 15.101 is not impaired (IEC 60335-2-15)		N/A
21.2	Accessible parts of solid insulation having strength to prevent penetration by sharp implements		P
	Test not applicable if the thickness of supplementary insulation is at least 1 mm and reinforced insulation at least 2 mm	See clause 29.3.1	P
	The insulation is tested as specified, and does withstand the electric strength test of 16.3		N/A

IEC 60335-2-15			
Clause	Requirement + Test	Result - Remark	Verdict
22	CONSTRUCTION		--
22.1	Appliance marked with the first numeral of the IP system, relevant requirements of IEC 60529 are fulfilled		P
22.2	Stationary appliance: means to ensure all-pole disconnection from the supply being provided:		--
	- a supply cord fitted with a plug, or		N/A
	- a switch complying with 24.3, or		N/A
	- a statement in the instruction sheet that a disconnection incorporated in the fixed wiring is to be provided, or		N/A
	- an appliance inlet		N/A
	Single-pole switches and single-pole protective devices for the disconnection of heating elements in single-phase, permanently connected class 0I and class I appliances, connected to the phase conductor		N/A
22.3	Appliance provided with pins: no undue strain on socket-outlets		N/A
	Applied torque not exceeding 0,25 Nm		N/A
	Pull force of 50 N to each pin after the appliance has being placed in the heating cabinet; when cooled to room temperature the pins are not displaced by more than 1 mm		N/A
	Each pin subjected to a torque of 0,4 Nm; the pins are not rotating, unless		N/A
	rotating does not impair compliance with this standard		N/A
22.4	Appliance for heating liquids and appliance causing undue vibration not provided with pins for insertion into socket-outlets		P
22.5	No risk of electric shock when touching pins, for appliances having a capacitor with rated capacitance equal to or greater than 0,1μF, the appliance being disconnected from the supply at the instant of voltage peak		N/A
	Voltage not exceeding 34 V (V)..... :		N/A
	If compliance relies on the operation of an electronic circuit, the electromagnetic phenomena tests of 19.11.4.3 and 19.11.4.4 are applied		N/A
	The discharge test is then repeated three times, voltage not exceeding 34 V (V)..... :		N/A
22.6	Electrical insulation not affected by condensing water or leaking liquid		P

IEC 60335-2-15			
Clause	Requirement + Test	Result - Remark	Verdict
	Electrical insulation of class II appliances not affected if a hose ruptures or seal leaks		N/A
	In case of doubt, test as described		N/A
	Drain holes, at least 5 mm in diameter or 20 mm ² in area with a width of at least 3 mm (IEC 60335-2-15)		P
22.7	Adequate safeguards against the risk of excessive pressure in appliances containing liquid or gases or having steam-producing devices		P
	Additional test for espresso coffee-maker: (IEC 60335-2-15, AMD1)		--
	Appliance operated with coffee filter blocked and outlet closed. The maximum pressure attained is measured, then the appliance is subjected to twice the measure pressure for 5 min		N/A
	No rupture, no leakage other than through a self-resetting pressure-relief device or intentionally weak part		N/A
	If a self-resetting pressure relief device operates, the appliance shall be suitable for further use		N/A
	Maximum pressure test with pressure limiting devices made ineffective		N/A
	No explosion nor emission of dangerous jets of steam		N/A
	Last test repeated in case of rupture of an intentionally weak part: the appliance shall be terminated in the same mode		N/A
	All pressure regulating devices and all protective devices and intentionally weak parts are rendered inoperative and the lid is closed		N/A
	For pressure cookers, other than dynamic pressure cookers, the pressure is gradually increased hydraulically to two times the operating pressure of the protective device during the test of 19.4		N/A
	Dynamic pressure cookers: the pressure is gradually increased hydraulically to 50 kPa in excess of the operating pressure of the protective device or intentionally weak part during the test of 19.4		N/A
	No rupture of container		N/A
22.8	Electrical connections not subject to pulling during cleaning of compartments to which access can be gained without the aid of a tool, and that are likely to be cleaned in normal use		P
22.9	Insulation, internal wiring, windings, commutators and slip rings not exposed to oil, grease or similar substances, unless		P
	the substance has adequate insulating properties		N/A

IEC 60335-2-15			
Clause	Requirement + Test	Result - Remark	Verdict
22.10	Not possible to reset voltage-maintained non-self-resetting thermal cut-outs by the operation of an automatic switching device incorporated within the appliance, if:		N/A
	- a non-self-resetting thermal cut-out is required by the standard, and		N/A
	- a voltage maintained non-self-resetting thermal cut-out is used to meet it		N/A
	Non-self-resetting thermal motor protectors have a trip-free action, unless		N/A
	they are voltage maintained		N/A
	Reset buttons of non-self-resetting controls so located or protected that accidental resetting is unlikely		N/A
22.11	Reliable fixing of non-detachable parts that provide the necessary degree of protection against electric shock, moisture or contact with moving parts		P
	Obvious locked position of snap-in devices used for fixing such parts		N/A
	No deterioration of the fixing properties of snap-in devices used in parts that are likely to be removed during installation or servicing		N/A
	Tests as described		P
22.12	Handles, knobs etc. fixed in a reliable manner, if loosening result in a hazard		P
	Removing or fixing in wrong position of handles, knobs etc. indicating position of switches or similar components not possible, if resulting in a hazard		P
	A choking hazard does not apply to appliances for commercial use		P
	Axial force 15 N applied to parts, the shape being so that an axial pull is unlikely to be applied		P
	Axial force 30 N applied to parts, the shape being so that an axial pull is likely to be applied		P
	If the part is removed and can be contained within the small parts cylinder, it is considered to be a choking hazard		N/A
22.13	Unlikely that handles, when gripped as in normal use, make the operator's hand touch parts having a temperature rise exceeding the value specified for handles which are held for short periods only		P
22.14	No ragged or sharp edges creating a hazard for the user in normal use, or during user maintenance		P

IEC 60335-2-15			
Clause	Requirement + Test	Result - Remark	Verdict
	No exposed pointed ends of self-tapping screws or other fasteners, likely to be touched by the user in normal use or during user maintenance		N/A
22.15	Storage hooks and the like for flexible cords smooth and well rounded		N/A
22.16	Automatic cord reels cause no undue abrasion or damage to the sheath of the flexible cord, no breakage of conductors strands and no undue wear of contacts		N/A
	Cord reel tested with 6000 operations, as specified		N/A
	Electric strength test of 16.3, voltage of 1000 V applied		N/A
22.17	Spacers not removable from the outside by hand or by means of a screwdriver or a spanner		N/A
22.18	Current-carrying parts and other metal parts resistant to corrosion		P
22.19	Driving belts not relied upon to provide the required level of insulation, unless		N/A
	constructed to prevent inappropriate replacement		N/A
22.20	Direct contact between live parts and thermal insulation effectively prevented, unless		N/A
	material used is non-corrosive, non-hygroscopic and non-combustible		N/A
22.21	Wood, cotton, silk, ordinary paper and fibrous or hygroscopic material not used as insulation, unless		P
	impregnated		N/A
	This requirement does not apply to magnesium oxide and mineral ceramic fibres used for the electrical insulation of heating elements		P
22.22	Appliances not containing asbestos		P
22.23	Oils containing polychlorinated biphenyl (PCB) not used		P
22.24	Bare heating elements, except in class III appliances or class III constructions that do not contain live parts, adequately supported		N/A
	In case of rupture, the heating conductor is unlikely to come in contact with accessible metal parts		N/A
22.25	Sagging heating conductors, except in class III appliances or class III constructions that do not contain live parts, cannot come into contact with accessible metal parts		N/A
22.26	For class III constructions the insulation between parts operating at safety extra-low voltage and other live parts complies with the requirements for double or reinforced insulation		N/A

IEC 60335-2-15			
Clause	Requirement + Test	Result - Remark	Verdict
22.27	Parts connected by protective impedance separated by double or reinforced insulation		N/A
22.28	Metal parts of class II appliances conductively connected to gas pipes or in contact with water, separated from live parts by double or reinforced insulation		N/A
22.29	Class II appliances permanently connected to fixed wiring so constructed that the required degree of access to live parts is maintained after installation		N/A
22.30	Parts serving as supplementary or reinforced insulation fixed so that they cannot be removed without being seriously damaged, or		N/A
	so constructed that they cannot be replaced in an incorrect position, and so that if they are omitted, the appliance is rendered inoperable or manifestly incomplete		P
22.31	Neither clearances nor creepage distances over supplementary and reinforced insulation reduced below values specified in Clause 29 as a result of wear		P
	Neither clearances nor creepage distances between live parts and accessible parts reduced below values for supplementary insulation if wires, screws etc. become loose		P
22.32	Supplementary and reinforced insulation constructed or protected against pollution so that clearances or creepage distances are not reduced below the values in Clause 29		P
	Supplementary insulation of natural or synthetic rubber resistant to ageing, or arranged and dimensioned so that creepage distances are not reduced below values specified in 29.2		N/A
	Ceramic material not tightly sintered, similar materials or beads alone not used as supplementary or reinforced insulation		N/A
	Ceramic and similar porous material in which heating conductors are embedded is considered to be basic insulation, not reinforced insulation		P
	Oxygen bomb test at 70 °C for 96 h and 16 h at room temperature		N/A
22.33	Conductive liquids that are or may become accessible in normal use and conductive liquids that are in contact with unearthed accessible metal parts are not in direct contact with live parts, or		P
	unearthed metal parts separated from live parts by basic insulation only		N/A
	Electrodes not used for heating liquids		N/A

IEC 60335-2-15			
Clause	Requirement + Test	Result - Remark	Verdict
	For class II constructions, conductive liquids that are or may become accessible in normal use and conductive liquids that are in contact with unearthed accessible metal parts, not in direct contact with basic or reinforced insulation, unless		N/A
	the reinforced insulation consists of at least 3 layers		N/A
	For class II constructions, conductive liquids which are in contact with live parts, not in direct contact with reinforced insulation, unless		N/A
	the reinforced insulation consists of at least 3 layers		N/A
	An air layer not used as basic or supplementary insulation in a double insulation system if likely to be bridged by leaking liquid		P
22.34	Shafts of operating knobs, handles, levers etc. not live, unless		P
	the shaft is not accessible when the part is removed		N/A
22.35	For other than class III constructions, handles, levers and knobs, held or actuated in normal use, not becoming live in the event of a failure of basic insulation		P
	Such parts being of metal, and their shafts or fixings are likely to become live in the event of a failure of basic insulation, are either adequately covered by insulation material or their accessible parts are separated from their shafts or fixings by supplementary insulation		N/A
	This requirement does not apply to handles, levers and knobs on stationary appliances and cordless appliances, other than those of electrical components, provided they are reliably connected to an earthing terminal or earthing contact, or separated from live parts by earthed metal		N/A
	Insulating material covering metal handles, levers and knobs withstand the electric strength test of 16.3 for supplementary insulation		N/A
22.36	For appliances other than class III, handles continuously held in the hand in normal use so constructed that when gripped as in normal use, the operators hand is not likely to touch metal parts, unless		N/A
	they are separated from live parts by double or reinforced insulation		N/A
22.37	Capacitors in class II appliances not connected to accessible metal parts and their casings, if of metal, separated from accessible metal parts by supplementary insulation, unless		N/A
	the capacitors comply with 22.42		N/A

IEC 60335-2-15			
Clause	Requirement + Test	Result - Remark	Verdict
22.38	Capacitors not connected between the contacts of a thermal cut-out		P
22.39	Lampholders used only for the connection of lamps		N/A
22.40	Motor-operated appliances and combined appliances intended to be moved while in operation, or having accessible moving parts, fitted with a switch to control the motor. The actuating member of the switch being easily visible and accessible		N/A
	If the appliance cannot operate continuously, automatically or remotely without giving rise to a hazard, appliances for remote operation being fitted with a switch for stopping the operation. The actuating member of the switch being easily visible and accessible		N/A
	For soy milk makers, any switch controlling the motor also disconnect electronic circuits, if their malfunction would impair compliance with this standard (IEC 60335-2-15)		N/A
	Compliance is checked by the tests of Clause 19 (IEC 60335-2-15)		N/A
22.41	No components, other than lamps, containing mercury		P
22.42	Protective impedance consisting of at least two separate components		N/A
	Values specified in 8.1.4 not exceeded if any one of the components are short-circuited or open-circuited		N/A
	Resistors checked by the test of 14.1 a) in IEC 60065		N/A
	Capacitors checked by the tests for class Y capacitors in IEC 60384-14		N/A
22.43	Appliances adjustable for different voltages, accidental changing of the setting of the voltage unlikely to occur		N/A
22.44	Appliances not having an enclosure that is shaped or decorated like a toy		P
22.45	When air is used as reinforced insulation, clearances not reduced below the values specified in 29.1.3 due to deformation as a result of an external force applied to the enclosure		P
22.46	For programmable protective electronic circuits used to ensure compliance with the standard, the software contains measures to control the fault/error conditions in Table R.1		N/A

IEC 60335-2-15			
Clause	Requirement + Test	Result - Remark	Verdict
	Software that contains measures to control the fault/error conditions specified in Table R.2 is to be specified in parts 2 for particular constructions or to address specific hazards		N/A
	These requirements are not applicable to software used for functional purpose or compliance with Clause 11		N/A
22.47	Appliances connected to the water mains withstand the water pressure expected in normal use		N/A
	No leakage from any part, including any inlet water hose		N/A
22.48	Appliances connected to the water mains constructed to prevent backsiphonage of non-potable water		N/A
22.49	For remote operation, the duration of operation is to be set before the appliance can be started, unless		N/A
	the appliance switches off automatically or can operate continuously without hazard		N/A
22.50	Controls incorporated in the appliance take priority over controls actuated by remote operation		N/A
22.51	There is a control on the appliance manually adjusted to the setting for remote operation before the appliance can be operated in this mode		N/A
	There is a visual indication showing that the appliance is adjusted for remote operation		N/A
	These requirements not necessary on appliances that can operate as follows, without giving rise to a hazard:		--
	- continuously, or		N/A
	- automatically, or		N/A
	- remotely		N/A
22.52	Socket-outlets on appliances accessible to the user in accordance with the socket-outlet system used in the country in which the appliance is sold		N/A
22.53	Class II appliances and class III appliances that incorporate functionally earthed parts have at least double insulation or reinforced insulation between live parts and the functionally earthed parts		N/A
22.54	Button cells and batteries designated R1 not accessible without the aid of a tool, unless		N/A
	the cover of their compartment can only be opened after at least two independent movements have been applied simultaneously		N/A

IEC 60335-2-15			
Clause	Requirement + Test	Result - Remark	Verdict
22.55	Devices operated to stop the intended function of the appliance, if any, are be distinguished from other manual devices by means of shape, size, surface texture or position		P
	The requirement concerning position does not preclude use of a push on push off switch		P
	An indication when the device has been operated is given by:		--
	- tactile feedback from the actuator or from the appliance, or		P
	- reduction in heat output; or		N/A
	- audible and visible feedback		N/A
22.56	Detachable power supply part provided with the part of class III construction		N/A
22.57	The properties of non-metallic materials do not degrade from exposure to UV-C radiation, as specified in Annex T		N/A
	This requirement does not apply to glass, ceramics or similar materials		N/A
22.101	Kettles constructed so that the lid does not fall off when water is poured out (IEC 60335-2-15)		N/A
	Compliance is checked by the test as specified		N/A
	Lid not fall off and water only emitted from the spout		N/A
22.102	Kettles so constructed that there are no sudden jets of steam or hot water likely to expose the user to a hazard when the appliance is used as in normal use (IEC 60335-2-15)		N/A
	Compliance is checked by inspection during the test of Clause 11		N/A
22.103	Appliance coupler of cordless appliances constructed to withstand the stresses occurring during normal use (IEC 60335-2-15)		N/A
	Compliance is checked by the test as specified		N/A
	Appliance is placed on its stand and withdrawn for:		--
	- cordless kettles 10 000 times		N/A
	- cordless coffee makers 10 000 times		N/A
	- other cordless appliances 6000 times		N/A
	The test continued without current flowing for a further 10 000 times for cordless kettles and cordless coffee makers, or		N/A
	6000 times for other cordless appliances		N/A

IEC 60335-2-15			
Clause	Requirement + Test	Result - Remark	Verdict
	If a single stand is supplied with more than one cordless appliance, the test for each cordless appliance is carried out using the same stand		N/A
	The appliance is suitable for further use and compliance with 8.1, 16.3, 27.5 and Clause 29 not be impaired		N/A
	The test is carried out without current flowing if the connection contacts cannot make or break on load		N/A
22.104	Portable appliances in which water boil with a container greater than 3 l is filled to its rated capacity with the lid closed in accordance with instructions for use (IEC 60335-2-15)		P
	The plane is slowly inclined to an angle of 25°; if the appliance overturns, it is left in this position for 10 s and then returned to its normal position	Not overturn	P
	The rate of discharge of liquid does not exceed 16 l/min		N/A
22.105	Fixed appliances for boiling water constructed so that the container is always open to the atmosphere through an aperture of at least 5 mm in diameter or 20 mm ² in area with a width of at least 3 mm (IEC 60335-2-15)		N/A
	Aperture not likely to be obstructed in normal use		N/A
	If the appliance has provisions for discharging steam or water overflowing, the discharge aperture shall be at the base of the appliance and discharge vertically downwards		N/A
	Compliance is checked by inspection and by measurement		N/A
22.106	Espresso coffee-maker: not possible to remove the filter by a simple operation while there is hazardous pressure within the container (IEC 60335-2-15)		N/A
	Compliance is checked by inspection and by manual test		N/A
	This requirement is considered to be met if the coffee filter can only be removed after it has been rotated through an angle of at least 30°		N/A
22.107	Pressure cookers incorporate a non-self-resetting pressure or temperature responsive pressure relief device (IEC 60335-2-15)		N/A
	Compliance is checked by inspection		N/A
22.108	Pressure cooker: not possible to remove the lid when the inner pressure is excessive (IEC 60335-2-15)		N/A
	Pressure test at 4 kPa and 100 N		N/A

IEC 60335-2-15			
Clause	Requirement + Test	Result - Remark	Verdict
	No hazardous displacement of lid at removal		N/A
	Test not carried out on pressure cookers when the lid is secured by screw clamps or other devices that ensure that the pressure is automatically reduced in a controlled manner before the lid can be removed		N/A
22.109	Pressure cookers constructed so that the pressure in the container is not excessive when the lid is not closed or is incorrectly fitted (IEC 60335-2-15)		N/A
	Compliance is checked by the test as specified		N/A
	Pressure not exceeding 4,0 kPa		N/A
22.110	Feeding-bottle heater: visible or audible signal to indicate the end of the heating period (IEC 60335-2-15)		N/A
	Compliance is checked by inspection during the test of Clause 11		N/A
22.111	Espresso coffee-makers, incorporating a pressurized reservoir filled by the user constructed so that there is no spillage of water or sudden jets of steam or hot water (IEC 60335-2-15)		N/A
	When removing the filling cap of the pressurized reservoir, before the cap is removed completely, the pressure relieves in a controlled manner		N/A
	Compliance is checked by inspection during the test of Clause 11 and by removing the filling cap at the end of the test		N/A
22.112	Soy milk makers constructed so that steam or hot water are not ejected which may expose the user to a hazard (IEC 60335-2-15)		N/A
	Compliance is checked by inspection		N/A
22.113	Appliances with moving mechanical parts constructed so that lubricants are prevented from polluting food compartments (IEC 60335-2-15)		N/A
	Compliance is checked by inspection		N/A
22.114	Appliances constructed so that food or liquids are prevented from penetrating into places that could cause electrical or mechanical faults (IEC 60335-2-15)		P
	Compliance is checked by inspection		P
22.115	Coffee-makers shall be constructed so that it is not possible to rotate the frothing nozzle or hot water nozzle through an angle of more than 45° upwards from the downwards facing vertical position (IEC 60335-2-15, AMD1)		N/A
	Compliance is checked by inspection and by manual test		N/A

IEC 60335-2-15			
Clause	Requirement + Test	Result - Remark	Verdict
23	INTERNAL WIRING		--
23.1	Wireways smooth and free from sharp edges		P
	Wires protected against contact with burrs, cooling fins etc.		N/A
	Wire holes in metal well-rounded or provided with bushings		N/A
	Wiring effectively prevented from coming into contact with moving parts		N/A
23.2	Beads etc. on live wires cannot change their position, and are not resting on sharp edges		N/A
	Beads inside flexible metal conduits contained within an insulating sleeve		N/A
23.3	Electrical connections and internal conductors movable relatively to each other not exposed to undue stress		N/A
	Flexible metallic tubes not causing damage to insulation of conductors		N/A
	Open-coil springs not used		N/A
	Adequate insulating lining provided inside a coiled spring, the turns of which touch one another		N/A
	No damage after 10 000 flexings for conductors flexed during normal use, or		N/A
	100 flexings for conductors flexed during user maintenance		N/A
	Electric strength test of 16.3, 1000 V between live parts and accessible metal parts		N/A
	Not more than 10 % of the strands of any conductor broken, and		N/A
	not more than 30 % for wiring supplying circuits that consume no more than 15 W		N/A
23.4	Bare internal wiring sufficiently rigid and fixed		N/A
23.5	The insulation of internal wiring subjected to the supply mains voltage withstanding the electrical stress likely to occur in normal use		P
	Basic insulation electrically equivalent to the basic insulation of cords complying with IEC 60227 or IEC 60245, or		N/A
	no breakdown when a voltage of 2000 V is applied for 15 min between the conductor and metal foil wrapped around the insulation		P
	For class II construction, the requirements for supplementary insulation and reinforced insulation apply,		N/A

IEC 60335-2-15			
Clause	Requirement + Test	Result - Remark	Verdict
	except that the sheath of a cord complying with IEC 60227 or IEC 60245 may provide supplementary insulation		N/A
	A single layer of internal wiring insulation does not provide reinforced insulation		P
23.6	Sleeving used as supplementary insulation on internal wiring retained in position by clamping at both ends, or		N/A
	be such that it can only be removed by breaking or cutting		N/A
23.7	The colour combination green/yellow only used for earthing conductors		P
23.8	Aluminium wires not used for internal wiring	No aluminium wire	P
23.9	Stranded conductors not consolidated by soldering where they are subjected to contact pressure, unless		P
	the contact pressure is provided by spring terminals		N/A
23.10	The insulation and sheath of internal wiring, incorporated in external hoses for the connection of an appliance to the water mains, at least equivalent to that of light polyvinyl chloride sheathed flexible cord (60227 IEC 52)		N/A
24	COMPONENTS		--
24.1	Components comply with safety requirements in relevant IEC standards		P
	List of components :	(see appended table)	P
	Motors not required to comply with IEC 60034-1, they are tested as part of the appliance		N/A
	Relays tested as part of the appliance, or		N/A
	alternatively according to IEC 60730-1, and meeting the additional requirements in IEC 60335-1		N/A
	The requirements of Clause 29 apply between live parts of components and accessible parts of the appliance		P
	Components can comply with the requirements for clearances and creepage distances for functional insulation in the relevant component standard		P
	30.2 of this standard apply to parts of non-metallic material in components including parts of non-metallic material supporting current-carrying connections		P
	Components that have not been previously tested to comply with the IEC standard for the relevant component are tested according to the requirements of 30.2		P

IEC 60335-2-15			
Clause	Requirement + Test	Result - Remark	Verdict
	Components that have been previously tested to comply with the resistance to fire requirements in the IEC standard for the relevant component need not be retested provided the specified conditions are met		P
	If these conditions are not satisfied, the component is tested as part of the appliance		P
	Power electronic converter circuits not required to comply with IEC 62477-1, they are tested as part of the appliance		N/A
	If components have not been tested and found to comply with relevant IEC standard for the number of cycles specified, they are tested in accordance with 24.1.1 to 24.1.9		P
	For components mentioned in 24.1.1 to 24.1.9 no additional tests specified in the relevant component standard are necessary other than those specified in 24.1.1 to 24.1.9		P
	Components not tested and found to comply with relevant IEC standard and components not marked or not used in accordance with its marking, tested under the conditions occurring in the appliance		P
	Lamp holders and starter holders that have not being tested and found to comply with the relevant IEC standard, tested as a part of the appliance and additionally according to the gauging and interchangeability requirements of the relevant IEC standard		N/A
	No additional tests specified for nationally standardized plugs such as those detailed in IEC/TR 60083 or connectors complying with the standard sheets of IEC 60320-1 and IEC 60309		P
24.1.1	Capacitors likely to be permanently subjected to the supply voltage and used for radio interference suppression or for voltage dividing, comply with IEC 60384-14		N/A
	If the capacitors have to be tested, they are tested according to Annex F		N/A
24.1.2	Transformers in associated switch mode power supplies comply with Annex BB of IEC 61558-2-16		N/A
	Safety isolating transformers comply with IEC 61558-2-6		N/A
	If they have to be tested, they are tested according to Annex G		N/A
24.1.3	Switches comply with IEC 61058-1, the number of cycles of operation being at least 10 000		P
	If they have to be tested, they are tested according to Annex H		P

IEC 60335-2-15			
Clause	Requirement + Test	Result - Remark	Verdict
	If the switch operates a relay or contactor, the complete switching system is subjected to the test		N/A
	If the switch only operates a motor starting relay complying with IEC 60730-2-10 with the number of cycles of a least 10 000 as specified, the complete switching system need not be tested		N/A
	Switches incorporated in espresso coffee-makers for initiating brewing or steaming tested for 10 000 cycles (IEC 60335-2-15)		N/A
	Switches incorporated in dynamic pressure cookers for controlling heaters are subjected to 50 000 cycles of operation and are tested under the conditions of Clause 11 with the appliance supplied at rated voltage (IEC 60335-2-15)		N/A
24.1.4	Automatic controls comply with IEC 60730-1 with the relevant part 2. The number of cycles of operation being at least:		--
	- thermostats:	10 000	P
	- temperature limiters:	1000	P
	- self-resetting thermal cut-outs:	300	P
	- voltage maintained non-self-resetting thermal cut-outs:	1000	N/A
	- other non-self-resetting thermal cut-outs:	30	N/A
	- timers:	3000	N/A
	- energy regulators:	10 000	N/A
	The number of cycles for controls operating during Clause 11 need not be declared, if the appliance meets the requirements of this standard when they are short-circuited		N/A
	Thermal motor protectors are tested in combination with their motor under the conditions specified in Annex D		N/A
	For water valves containing live parts and that are incorporated in external hoses for connection of an appliance to the water mains, the degree of protection declared for Sub-clause 6.5.2 of IEC 60730-2-8 is IPX7		N/A
	Thermal cut-outs of the capillary type comply with the requirements for type 2.K controls in IEC 60730-2-9		N/A
	Self-resetting thermal cut-outs required for compliance with the test of 19.101 are subjected to 3000 cycles of operation (IEC 60335-2-15)		N/A
24.1.5	Appliance couplers comply with IEC 60320-1		N/A

IEC 60335-2-15			
Clause	Requirement + Test	Result - Remark	Verdict
	However, for class II appliances classified higher than IPX0, the appliance couplers comply with IEC 60320-2-3		N/A
	Interconnection couplers comply with IEC 60320-2-2		N/A
	Appliance couplers incorporating thermostats, thermal cut-outs or fuses in the connectors comply with IEC 60320-1, except that: (IEC 60335-2-15)		N/A
	- the earthing contact of connector is allowed to be accessible, if contact is not likely to be gripped during insertion or withdrawal of the connector;		N/A
	- the temperature required for the test of Clause 18 is that measured on the pins of the appliance inlet during test of Clause 11 of this standard;		N/A
	- the breaking-capacity test of Clause 19 carried out using the inlet of the appliance;		N/A
	- the temperature rise of current-carrying parts specified in Clause 21 not determined		N/A
	Thermal controls are not allowed in connectors complying with the standard sheets of IEC 60320-1 (IEC 60335-2-15)		N/A
24.1.6	Small lampholders similar to E10 lampholders comply with IEC 60238, the requirements for E10 lampholders being applicable		N/A
24.1.7	For remote operation of the appliance via a telecommunication network, the relevant standard for the telecommunication interface circuitry in the appliance is IEC 62151		N/A
24.1.8	The relevant standard for thermal links is IEC 60691		P
	Thermal links not complying with IEC 60691 are considered to be an intentionally weak part for the purposes of Clause 19		N/A
24.1.9	Contactors and relays, other than motor starting relays, tested as part of the appliance		N/A
	They are also tested in accordance with Clause 17 of IEC 60730-1, the number of cycles of operations in 24.1.4 selected according to the contactor or relay function in the appliance:		N/A
24.2	Appliances not fitted with:		--
	- switches, automatic controls or power supplies in flexible cords		P
	- devices causing the protective device in the fixed wiring to operate in the event of a fault in the appliance;		P

IEC 60335-2-15			
Clause	Requirement + Test	Result - Remark	Verdict
	- thermal cut-outs that can be reset by soldering, unless		P
	the solder has a melting point of at least 230 °C		N/A
24.3	Switches intended for all-pole disconnection of stationary appliances are directly connected to the supply terminals and have a contact separation in all poles, providing full disconnection under overvoltage category III conditions		N/A
24.4	Plugs and socket-outlets for extra-low voltage circuits and heating elements, not interchangeable with plugs and socket-outlets listed in IEC/TR 60083 or IEC 60906-1 or with connectors and appliance inlets complying with the standard sheets of IEC 60320-1		N/A
	Not applicable to the connection between the appliance and the stand of cordless appliances (IEC 60335-2-15)		N/A
24.5	Capacitors in auxiliary windings of motors marked with their rated voltage and capacitance, and used accordingly		N/A
	Voltage across capacitors in series with a motor winding does not exceed 1,1 times rated voltage, when the appliance is supplied at 1,1 times rated voltage under minimum load		N/A
24.6	Working voltage of motors connected to the supply mains and having basic insulation that is inadequate for the rated voltage of the appliance, not exceeding 42 V		N/A
	In addition, the motors comply with the requirements of Annex I		N/A
24.7	Detachable hose-sets for connection of appliances to the water mains comply with IEC 61770		N/A
	They are supplied with the appliance		N/A
	Appliances intended to be permanently connected to the water mains not connected by a detachable hose-set		N/A
24.8	Motor running capacitors in appliances for which 30.2.3 is applicable and that are permanently connected in series with a motor winding, not causing a hazard in event of a failure		N/A
	One or more of the following conditions are to be met:		--
	- the capacitors are of class S2 or S3 according to IEC 60252-1;		N/A
	- the capacitors are housed within a metallic or ceramic enclosure;		N/A

IEC 60335-2-15			
Clause	Requirement + Test	Result - Remark	Verdict
	- the distance of separation of the outer surface to adjacent non-metallic parts exceeds 50 mm;		N/A
	- adjacent non-metallic parts within 50 mm withstand the needle-flame test of Annex E;		N/A
	- adjacent non-metallic parts within 50 mm classified as at least V-1 according to IEC 60695-11-10		N/A
24.101	Devices incorporated in appliance, other than kettles, in order to comply with 19.4 are non-self-resetting (IEC 60335-2-15)		P
	However, self-resetting thermal cut-outs are allowed for fixed water boilers, if they have been tested for 10 000 cycles of operation		N/A
	Compliance is checked by inspection and during the test of 19.4		P
25	SUPPLY CONNECTION AND EXTERNAL FLEXIBLE CORDS		--
25.1	Appliance not intended for permanent connection to fixed wiring, means for connection to the supply:		--
	- supply cord fitted with a plug, the current rating and voltage rating of the plug being not less than the corresponding ratings of its associated appliance;		P
	- an appliance inlet having at least the same degree of protection against moisture as required for the appliance, or		P
	- pins for insertion into socket-outlets		N/A
	Appliances incorporating an appliance inlet other than those standardized in IEC 60320-1 are supplied with a cord set (IEC 60335-2-15)		N/A
25.2	Appliance not provided with more than one means of connection to the supply mains		P
	Stationary appliance for multiple supply may be provided with more than one means of connection, provided electric strength test of 1250 V for 1 min between each means of connection causes no breakdown		N/A
25.3	Appliance intended to be permanently connected to fixed wiring provided with one of the following means for connection to the supply mains:		--
	- a set of terminals allowing the connection of a flexible cord;		N/A
	- a fitted supply cord;		N/A
	- a set of supply leads accommodated in a suitable compartment;		N/A

IEC 60335-2-15			
Clause	Requirement + Test	Result - Remark	Verdict
	- a set of terminals for the connection of cables of fixed wiring, cross-sectional areas specified in 26.6, and the appliance allows the connection of the supply conductors after the appliance has been fixed to its support;		N/A
	- a set of terminals and cable entries, conduit entries, knock-outs or glands, allowing connection of appropriate types of cable or conduit, and the appliance allows the connection of the supply conductors after the appliance has been fixed to its support		N/A
	For a fixed appliance constructed so that parts can be removed to facilitate easy installation, this requirement is met if it is possible to connect the fixed wiring without difficulty after a part of the appliance has been fixed to its support		N/A
25.4	Cable and conduit entries, rated current of appliance not exceeding 16 A, dimension according to Table 10 (mm) :		N/A
	Introduction of conduit or cable does not reduce clearances or creepage distances below values specified in Clause 29		N/A

IEC 60335-2-15			
Clause	Requirement + Test	Result - Remark	Verdict
25.5	Method for assembling the supply cord to the appliance:		--
	- type X attachment		N/A
	- type Y attachment		P
	- type Z attachment, if allowed in relevant part 2		N/A
	Type Z attachment is allowed for egg boilers, feeding bottle heaters, yoghurt makers and stands of cordless appliances (IEC 60335-2-15)		N/A
	Type X attachment, other than those with a specially prepared cord, not used for flat twin tinsel cords		N/A
	For multi-phase appliances supplied with a supply cord and that are intended to be permanently connected to fixed wiring, the supply cord is assembled to the appliance by type Y attachment		N/A
25.6	Plugs fitted with only one flexible cord		P
25.7	Supply cords, other than for class III appliances, being one of the following types:		--
	- rubber sheathed (at least 60245 IEC 53)		N/A
	- polychloroprene sheathed (at least 60245 IEC 57)		N/A
	- polyvinyl chloride sheathed. Not used if they are likely to touch metal parts having a temperature rise exceeding 75 K during the test of Clause 11		--
	<ul style="list-style-type: none"> light polyvinyl chloride sheathed cord (60227 IEC 52), for appliances not exceeding 3 kg; 	H03VV-F (for models not more than 550W)	P
	<ul style="list-style-type: none"> ordinary polyvinyl chloride sheathed cord (60227 IEC 53), for other appliances 	H05VV-F	P
	- heat resistant polyvinyl chloride sheathed. Not used for type X attachment other than specially prepared cords		--
	<ul style="list-style-type: none"> heat-resistant light polyvinyl chloride sheathed cord (60227 IEC 56), for appliances not exceeding 3 kg; 		N/A
	<ul style="list-style-type: none"> heat-resistant polyvinyl chloride sheathed cord (60227 IEC 57), for other appliances 		N/A
	- halogen-free, low smoke, thermoplastic insulated and sheathed		--
	<ul style="list-style-type: none"> Light duty halogen-free low smoke flexible cable (62821 IEC 101) for circular cable and (62821 IEC 101f) for flat cable 		N/A
	<ul style="list-style-type: none"> Ordinary duty halogen-free low smoke flexible cable (62821 IEC 102) for circular cable and (62821 IEC 102f) for flat cable 		N/A
	Supply cords for class III appliances adequately insulated		N/A

IEC 60335-2-15			
Clause	Requirement + Test	Result - Remark	Verdict
	Test with 500 V for 2 min for supply cords of class III appliances that contain live parts		N/A
	Supply cord of livestock feed boilers are polychloroprene sheathed (IEC 60335-2-15)		N/A
25.8	Nominal cross-sectional area of supply cords not less than Table 11; rated current (A); cross-sectional area (mm ²)	Max. 2,50A, 0,5mm ² or 0,75mm ² for models not more than 550W, Length < 2m; Max. 9,98A, 0,75mm ² or 1,0 0,75mm ² for models not more than 2200 W, Length < 2m; Max. 15,88A, 1,0mm ² or 1,5mm ² for models not more than 3500 W, Length < 2m;	P
	Portable appliances having a rated current of up to 10 A may incorporate a supply cord having a nominal cross-sectional area of 0,75 mm ² , if the length is less than 2 m (IEC 60335-2-15)		N/A
25.9	Supply cords not in contact with sharp points or edges		P
25.10	Supply cord of class I appliances have a green/yellow core for earthing		P
	In multi-phase appliances, the colour of the neutral conductor of the supply cord is blue		N/A
	Where additional neutral conductors are provided in the supply cord:		--
	– other colours may be used for these additional neutral conductors;		N/A
	– all of the neutral conductors and line conductors are identified by marking using the alpha numeric notation specified in IEC 60445		N/A
	– the supply cord is fitted to the appliance		N/A
25.11	Conductors of supply cords not consolidated by soldering where they are subject to contact pressure, unless		P
	the contact pressure is provided by spring terminals		N/A
25.12	Insulation of the supply cord not damaged when moulding the cord to part of the enclosure		P
25.13	Inlet openings so constructed as to prevent damage to the supply cord		P
	If it is not evident that the supply cord can be introduced without risk of damage, a non-detachable lining or bushing complying with 29.3 for supplementary insulation provided		N/A

IEC 60335-2-15			
Clause	Requirement + Test	Result - Remark	Verdict
	If unsheathed supply cord, a similar additional bushing or lining is required, unless the appliance is		N/A
	class 0, or		N/A
	a class III appliance not containing live parts		N/A
25.14	Supply cords moved while in operation adequately protected against excessive flexing		N/A
	Flexing test, as described:		--
	- applied force (N)..... :		N/A
	- number of flexings..... :		N/A
	The test does not result in:		--
	- short-circuit between the conductors, such that the current exceeds a value of twice the rated current;		N/A
	- breakage of more than 10 % of the strands of any conductor;		N/A
	- separation of the conductor from its terminal;		N/A
	- loosening of any cord guard;		N/A
	- damage to the cord or the cord guard;		N/A
	- broken strands piercing the insulation and becoming accessible		N/A
25.15	For appliances with supply cord and appliances to be permanently connected to fixed wiring by a flexible cord, conductors of the supply cord relieved from strain, twisting and abrasion by use of cord anchorage		P
	The cord cannot be pushed into the appliance to such an extent that the cord or internal parts of the appliance can be damaged		P
	Pull and torque test of supply cord:		--
	- fixed appliances: pull 100 N; torque (not on automatic cord reel) (Nm)..... :		N/A
	- other appliances: values shown in Table 12: mass (kg); pull (N); torque (not on automatic cord reel) (Nm)..... :	100N, 0,35Nm	P
	Cord not damaged and max. 2 mm displacement of the cord	0,5mm	P
25.16	Cord anchorages for type X attachments constructed and located so that:		--
	- replacement of the cord is easily possible;		N/A
	- it is clear how the relief from strain and the prevention of twisting are obtained;		N/A
	- they are suitable for different types of supply cord;		N/A

IEC 60335-2-15			
Clause	Requirement + Test	Result - Remark	Verdict
	- cord cannot touch the clamping screws of cord anchorage if these screws are accessible, unless		N/A
	they are separated from accessible metal parts by supplementary insulation;		N/A
	- the cord is not clamped by a metal screw which bears directly on the cord;		N/A
	- at least one part of the cord anchorage securely fixed to the appliance, unless		N/A
	it is part of a specially prepared cord;		N/A
	- screws which have to be operated when replacing the cord do not fix any other component, unless		N/A
	the appliance becomes inoperative or incomplete or the parts cannot be removed without a tool;		N/A
	- if labyrinths can be bypassed the test of 25.15 is nevertheless withstood;		N/A
	- for class 0, 0I and I appliances they are of insulating material or are provided with an insulating lining, unless		N/A
	failure of the insulation of the cord does not make accessible metal parts live;		N/A
	- for class II appliances they are of insulating material, or		N/A
	if of metal, they are insulated from accessible metal parts by supplementary insulation		N/A
	After the test of 25.15, under the conditions specified, the conductors have not moved by more than 1 mm in the terminals		N/A
25.17	Adequate cord anchorages for type Y and Z attachment, test with the cord supplied with the appliance		P
25.18	Cord anchorages only accessible with the aid of a tool, or		N/A
	constructed so that the cord can only be fitted with the aid of a tool		P
25.19	Type X attachment, glands not used as cord anchorage in portable appliances		N/A
	Tying the cord into a knot or tying the cord with string not used		N/A
25.20	The conductors of the supply cord for type Y and Z attachment insulated from accessible metal parts		P
25.21	Space for supply cord for type X attachment or for connection of fixed wiring constructed:		--

IEC 60335-2-15			
Clause	Requirement + Test	Result - Remark	Verdict
	- to permit checking of conductors with respect to correct positioning and connection before fitting any cover;		N/A
	- so there is no risk of damage to the conductors or their insulation when fitting the cover;		N/A
	- for portable appliances, so that the uninsulated end of a conductor, if it becomes free from the terminal, prevented from contact with accessible metal parts		N/A
	2 N test to the conductor for portable appliances; no contact with accessible metal parts		N/A
25.22	Appliance inlets:		--
	- live parts not accessible during insertion or removal		P
	Requirement not applicable to appliance inlets complying with IEC 60320-1;		P
	- connector can be inserted without difficulty;		P
	- the appliance is not supported by the connector;		P
	- not for cold conditions if temp. rise of external metal parts exceeds 75 K during Clause 11, unless		P
	the supply cord is unlikely to touch such metal parts		N/A
	Soy milk maker inlets located so that pollution by soy milk is unlikely to occur during normal use (IEC 60335-2-15)		N/A
25.23	Interconnection cords comply with the requirements for the supply cord, except that:		--
	- the cross-sectional area of the conductors is determined on the basis of the maximum current during Clause 11		N/A
	- the thickness of the insulation may be reduced		N/A
	- for class I or class II appliance with class III construction, the cross sectional areas of the conductors need not comply with 25.8 if specified conditions are met		N/A
	If necessary, electric strength test of 16.3		N/A
25.24	Interconnection cords not detachable without the aid of a tool if compliance with this standard is impaired when they are disconnected		N/A
25.25	Dimensions of pins that are inserted into socket-outlets compatible with the dimensions of the relevant socket-outlet		N/A
	Dimensions of pins and engagement face in accordance with the dimensions of the relevant plug in IEC/TR 60083		N/A

IEC 60335-2-15			
Clause	Requirement + Test	Result - Remark	Verdict
25.101	Supply cords of kettles are not longer than 75 cm, unless they are helically coiled (IEC 60335-2-15)		N/A
	If a cordless kettle has a cord storage facility, the length of the cord is measured after storing as much of the cord as possible		N/A
	The length of the cord is measured between the plug and the point where the cord or cord guard enters the appliance		N/A
26	TERMINALS FOR EXTERNAL CONDUCTORS		--
26.1	Appliances provided with terminals or equally effective devices for connection of external conductors		P
	Terminals only accessible after removal of a non-detachable cover, except		P
	for class III appliances that do not contain live parts		N/A
	Earthing terminals may be accessible if a tool is required to make the connections and means are provided to clamp the wire independently from its connection		N/A
26.2	Appliances with type X attachment and appliances for the connection of cables to fixed wiring provided with terminals in which connections are made by means of screws, nuts or similar devices, unless		N/A
	the connections are soldered		N/A
	Screws and nuts not used to fix any other component, except		N/A
	internal conductors, if so arranged that they are unlikely to be displaced when fitting the supply conductors		N/A
	If soldered connections used, the conductor so positioned or fixed that reliance is not placed on soldering alone, unless		N/A
	barriers provided so that neither clearances nor creepage distances between live parts and other metal parts reduced below the values for supplementary insulation if the conductor becomes free at the soldered joint		N/A
26.3	Terminals for type X attachment and for connection of cables of fixed wiring so constructed that the conductor is clamped between metal surfaces with sufficient contact pressure but without damaging the conductor		N/A
	Terminals fixed so that when the clamping means is tightened or loosened:		--
	- the terminal does not become loose;		N/A
	- internal wiring is not subjected to stress;		N/A

IEC 60335-2-15			
Clause	Requirement + Test	Result - Remark	Verdict
	- neither clearances nor creepage distances are reduced below the values in Clause 29		N/A
	Compliance checked by inspection and by the test of Sub-clause 9.6 of IEC 60999-1, the torque applied being equal to two-thirds of the torque specified (Nm)		N/A
	No deep or sharp indentations of the conductors		N/A
26.4	Terminals for type X attachment, except those having a specially prepared cord and those for the connection of cables of fixed wiring, no special preparation of conductors such as by soldering, use of cable lugs, eyelets or similar, and		N/A
	so constructed or placed that conductors prevented from slipping out when clamping screws or nuts are tightened		N/A
26.5	Terminals for type X attachment so located or shielded that if a wire of a stranded conductor escapes, no risk of accidental connection to other parts that result in a hazard		N/A
	Stranded conductor test, 8 mm insulation removed		N/A
	No contact between live parts and accessible metal parts and,		N/A
	for class II constructions, between live parts and metal parts separated from accessible metal parts by supplementary insulation only		N/A
26.6	Terminals for type X attachment and for connection of cables of fixed wiring suitable for connection of conductors with cross-sectional area according to Table 13; rated current (A); nominal cross-sectional area (mm ²).....		N/A
	If a specially prepared cord is used, terminals need only be suitable for that cord		N/A
26.7	Terminals for type X attachment, except in class III appliances not containing live parts, accessible after removal of a cover or part of the enclosure		N/A
26.8	Terminals for the connection of fixed wiring, including the earthing terminal, located close to each other		N/A
26.9	Terminals of the pillar type constructed and located as specified		N/A
26.10	Terminals with screw clamping and screwless terminals not used for flat twin tinsel cords, unless		N/A
	conductors ends fitted with means suitable for screw terminals		N/A
	Pull test of 5 N to the connection		N/A

IEC 60335-2-15			
Clause	Requirement + Test	Result - Remark	Verdict
26.11	For type Y and Z attachment, soldered, welded, crimped or similar connections may be used		P
	For class II appliances, the conductor so positioned or fixed that reliance is not placed on soldering, welding or crimping alone		N/A
	If soldering, welding or crimping alone used, barriers provided so that clearances and creepage distances between live parts and other metal parts are not reduced below the values for supplementary insulation if the conductor becomes free		N/A
27	PROVISION FOR EARTHING		--
27.1	Accessible metal parts of Class 0I and I appliances permanently and reliably connected to an earthing terminal or earthing contact of the appliance inlet		P
	Earthing terminals and earthing contacts not connected to the neutral terminal		P
	Class 0, II and III appliances have no provision for protective earthing		N/A
	Class II appliances and class III appliances can incorporate an earth for functional purposes		N/A
	Safety extra-low voltage circuits not earthed, unless		N/A
	protective extra-low voltage circuits		N/A
27.2	Clamping means of earthing terminals adequately secured against accidental loosening		P
	Terminals for the connection of external equipotential bonding conductors allow connection of conductors of 2,5 to 6 mm ² , and		N/A
	do not provide earthing continuity between different parts of the appliance, and		N/A
	conductors cannot be loosened without the aid of a tool		N/A
	Requirements not applicable to class II appliances and class III appliances that incorporate an earth for functional purposes		N/A
27.3	For a detachable part having an earth connection and being plugged into another part of the appliance, the earth connection is made before and separated after current-carrying connections when removing the part		P
	For appliances with supply cords, current-carrying conductors become taut before earthing conductor, if the cord slips out of the cord anchorage		P
	Requirements not applicable to class II appliances and class III appliances that incorporate an earth for functional purposes		N/A

IEC 60335-2-15			
Clause	Requirement + Test	Result - Remark	Verdict
27.4	No risk of corrosion resulting from contact between parts of the earthing terminal and the copper of the earthing conductor or other metal		P
	Parts providing earthing continuity, other than parts of a metal frame or enclosure, have adequate resistance to corrosion		N/A
	If of steel, these parts provided with an electroplated coating with a thickness at least 5 µm		N/A
	Adequate protection against rusting of parts of coated or uncoated steel, only intended to provide or transmit contact pressure		N/A
	In the body of the earthing terminal is a part of a frame or enclosure of aluminium or aluminium alloys, precautions taken to avoid risk of corrosion		N/A
	Requirements not applicable to class II appliances and class III appliances that incorporate an earth for functional purposes		N/A
27.5	Low resistance of connection between earthing terminal and earthed metal parts		P
	This requirement does not apply to connections providing earthing continuity in the protective extra-low voltage circuit, provided the clearances of basic insulation are based on the rated voltage of the appliance		N/A
	Requirements not applicable to class II appliances and class III appliances that incorporate an earth for functional purposes		N/A
	Resistance not exceeding 0,1 Ω at the specified low-resistance test (Ω)..... :	0,058	P
27.6	The printed conductors of printed circuit boards not used to provide earthing continuity in hand-held appliances.		N/A
	They may be used to provide earthing continuity in other appliances if at least two tracks are used with independent soldering points and the appliance complies with 27.5 for each circuit		N/A
	Requirements not applicable to class II appliances and class III appliances that incorporate an earth for functional purposes		N/A
28.1	SCREWS AND CONNECTIONS		--
	Fixings, electrical connections and connections providing earthing continuity withstand mechanical stresses		P
	Screws not of soft metal liable to creep, such as zinc or aluminium		P
	Diameter of screws of insulating material min. 3 mm		N/A

IEC 60335-2-15			
Clause	Requirement + Test	Result - Remark	Verdict
	Screws of insulating material not used for any electrical connections or connections providing earthing continuity	No screw of insulating material	N/A
	Screws used for electrical connections or connections providing earthing continuity screwed into metal		P
	Screws not of insulating material if their replacement by a metal screw can impair supplementary or reinforced insulation	No screw of insulating material	N/A
	For type X attachment, screws to be removed for replacement of supply cord or for user maintenance, not of insulating material if their replacement by a metal screw impairs basic insulation		N/A
	For screws and nuts; torque-test as specified in Table 14..... :	(see appended table)	P
28.2	Electrical connections and connections providing earthing continuity constructed so that contact pressure is not transmitted through non-ceramic insulating material liable to shrink or distort, unless		P
	there is resiliency in the metallic parts to compensate for shrinkage or distortion of the insulating material		P
	This requirement does not apply to electrical connections in circuits of appliances for which:		--
	<ul style="list-style-type: none"> 30.2.2 is applicable and that carry a current not exceeding 0,5 A; 		N/A
	<ul style="list-style-type: none"> 30.2.3 is applicable and that carry a current not exceeding 0,2 A 		N/A
28.3	Space-threaded (sheet metal) screws only used for electrical connections if they clamp the parts together		N/A
	Thread-cutting (self-tapping) screws and thread rolling screws only used for electrical connections if they generate a full form standard machine screw thread		N/A
	Thread-cutting (self-tapping) screws not used if they are likely to be operated by the user or installer		N/A
	Thread-cutting, thread rolling and space threaded screws may be used in connections providing earthing continuity provided it is not necessary to disturb the connection:		--
	- in normal use,		N/A
	- during user maintenance,		N/A
	- when replacing a supply cord having a type X attachment, or		N/A

IEC 60335-2-15			
Clause	Requirement + Test	Result - Remark	Verdict
	- during installation		N/A
	At least two screws being used for each connection providing earthing continuity, unless		N/A
	the screw forms a thread having a length of at least half the diameter of the screw		N/A
28.4	Screws and nuts that make mechanical connection secured against loosening if they also make electrical connections or connections providing earthing continuity		P
	This requirement does not apply to screws in the earthing circuit if at least two screws are used, or		N/A
	if an alternative earthing circuit is provided		N/A
	Rivets for electrical connections or connections providing earthing continuity secured against loosening if the connections are subjected to torsion		N/A
29	CLEARANCES, CREEPAGE DISTANCES AND SOLID INSULATION		--
	Clearances, creepage distances and solid insulation withstand electrical stress		P
	For coatings used on printed circuits boards to protect the microenvironment (type 1) or to provide basic insulation (type 2), Annex J applies		N/A
	The microenvironment is pollution degree 1 under type 1 protection		N/A
	For type 2 protection, the spacing between the conductors before the protection is applied is not less than the values specified in Table 1 of IEC 60664-3		N/A
	These values apply to functional, basic, supplementary and reinforced insulation		N/A
29.1	Clearances not less than the values specified in Table 16, taking into account the rated impulse voltage for the overvoltage categories of Table 15, unless	(see appended table)	P
	for basic insulation and functional insulation they comply with the impulse voltage test of Clause 14		N/A
	However, if the distances are affected by wear, distortion, movement of the parts or during assembly, the clearances for rated impulse voltages of 1500 V and above are increased by 0,5 mm and the impulse voltage test is not applicable		P
	For appliances intended for use at altitudes exceeding 2 000 m, the clearances in Table 16 is increased according to the relevant multiplier values in Table A.2 of IEC 60664-1		N/A
	Impulse voltage test is not applicable:		--

IEC 60335-2-15			
Clause	Requirement + Test	Result - Remark	Verdict
	- when the microenvironment is pollution degree 3, or		P
	- for basic insulation of class 0 and class 0I appliances, or		N/A
	- to appliances intended for use at altitudes exceeding 2 000 m		N/A
	Appliances are in overvoltage category II		P
	A force of 2 N is applied to bare conductors, other than heating elements		P
	A force of 30 N is applied to accessible surfaces		P
29.1.1	Clearances of basic insulation withstand the overvoltages, taking into account the rated impulse voltage		P
	The values of Table 16 or the impulse voltage test of Clause 14 are applicable..... :		N/A
	Clearance at the terminals of tubular sheathed heating elements may be reduced to 1 mm if the microenvironment is pollution degree 1		P
	Lacquered conductors of windings considered to be bare conductors		P
29.1.2	Clearances of supplementary insulation not less than those specified for basic insulation in Table 16..... :	(see appended table)	P
29.1.3	Clearances of reinforced insulation not less than those specified for basic insulation in Table 16, using the next higher step for rated impulse voltage..... :	(see appended table)	P
	For double insulation, with no intermediate conductive part between basic and supplementary insulation, clearances are measured between live parts and the accessible surface, and the insulation system is treated as reinforced insulation		P
29.1.4	Clearances for functional insulation are the largest values determined from:		--
	- Table 16 based on the rated impulse voltage :	(see appended table)	P
	- Table F.7a in IEC 60664-1, frequency not exceeding 30 kHz;		N/A
	- Clause 4 of IEC 60664-4, frequency exceeding 30 kHz		N/A
	If values of Table 16 are largest, the impulse voltage test of Clause 14 may be applied instead, unless		N/A
	the microenvironment is pollution degree 3, or		P
	the distances can be affected by wear, distortion, movement of the parts or during assembly		P

IEC 60335-2-15			
Clause	Requirement + Test	Result - Remark	Verdict
	However, clearances are not specified if the appliance complies with Clause 19 with the functional insulation short-circuited		N/A
	Lacquered conductors of windings considered to be bare conductors		P
	However, clearances at crossover points are not measured		P
	Clearance between surfaces of PTC heating elements may be reduced to 1 mm		N/A
29.1.5	Appliances having higher working voltages than rated voltage, clearances for basic insulation are the largest values determined from:		--
	- Table 16 based on the rated impulse voltage :		N/A
	- Table F.7a in IEC 60664-1, frequency not exceeding 30 kHz;		N/A
	- Clause 4 of IEC 60664-4, frequency exceeding 30 kHz		N/A
	If clearances for basic insulation are selected from Table F.7a of IEC 60664-1 or Clause 4 of IEC 60664-4, the clearances of supplementary insulation are not less than those specified for basic insulation		N/A
	If clearances for basic insulation are selected from Table F.7a of IEC 60664-1, the clearances of reinforced insulation dimensioned as specified in Table F.7a are to withstand 160 % of the withstand voltage required for basic insulation		N/A
	If clearances for basic insulation are selected from Clause 4 of IEC 60664-4, the clearances of reinforced insulation are twice the value required for basic insulation		N/A
	If the secondary winding of a step-down transformer is earthed, or if there is an earthed screen between the primary and secondary windings, clearances of basic insulation on the secondary side not less than those specified in Table 16, but using the next lower step for rated impulse voltage		N/A
	Circuits supplied with a voltage lower than rated voltage, clearances of functional insulation are based on the working voltage used as the rated voltage in Table 15		N/A
29.2	Creepage distances not less than those appropriate for the working voltage, taking into account the material group and the pollution degree..... :	(see appended table)	P
	Pollution degree 2 applies, unless		N/A
	- precautions taken to protect the insulation; pollution degree 1;		N/A

IEC 60335-2-15			
Clause	Requirement + Test	Result - Remark	Verdict
	- insulation subjected to conductive pollution; pollution degree 3		P
	The microenvironment is pollution degree 3 if the insulation can be polluted by condensation from steam produced during normal use of the appliance (IEC 60335-2-15)		P
	A force of 2 N is applied to bare conductors, other than heating elements		P
	A force of 30 N is applied to accessible surfaces		P
	In a double insulation system, the working voltage for both the basic and supplementary insulation is taken as the working voltage across the complete double insulation system		P
29.2.1	Creepage distances of basic insulation not less than specified in Table 17	(see appended table)	P
	However, if the working voltage is periodic and has a frequency exceeding 30 kHz, the creepage distances are also determined from Table 2 of IEC 60664-4, these values being used if exceeding the values in Table 17		N/A
	Except for pollution degree 1, corresponding creepage distance not less than the minimum specified for the clearance in Table 16, if the clearance has been checked according to the test of Clause 14		N/A
29.2.2	Creepage distances of supplementary insulation at least those specified for basic insulation in Table 17, or	(see appended table)	P
	Table 2 of IEC 60664-4, as applicable		N/A
29.2.3	Creepage distances of reinforced insulation at least double those specified for basic insulation in Table 17, or	(see appended table)	P
	Table 2 of IEC 60664-4, as applicable		N/A
29.2.4	Creepage distances of functional insulation not less than specified in Table 18	(see appended table)	P
	However, if the working voltage is periodic and has a frequency exceeding 30 kHz, the creepage distances are also determined from Table 2 of IEC 60664-4, these values being used if exceeding the values in Table 18		N/A
	Creepage distances may be reduced if the appliance complies with Clause 19 with the functional insulation short-circuited		N/A
29.3	Supplementary and reinforced insulation have adequate thickness, or a sufficient number of layers, to withstand the electrical stresses		P

IEC 60335-2-15			
Clause	Requirement + Test	Result - Remark	Verdict
	Compliance checked:		--
	- by measurement, in accordance with 29.3.1, or		P
	- by an electric strength test in accordance with 29.3.2, or		N/A
	- for insulation, other than single layer internal wiring insulation, by an assessment of the thermal quality of the material combined with an electric strength test, in accordance with 29.3.3, and		N/A
	for accessible parts of reinforced insulation consisting of a single layer, by measurement in accordance with 29.3.4, or		N/A
	- by an assessment of the thermal quality of the material according to 29.3.3 combined with an electric strength test in accordance with 23.5, for each single layer internal wiring insulation touching each other, or		N/A
	- as specified in Sub-clause 6.3 of IEC 60664-4 for insulation that is subjected to any periodic voltage having a frequency exceeding 30 kHz		N/A
29.3.1	Supplementary insulation have a thickness of at least 1 mm		P
	Reinforced insulation have a thickness of at least 2 mm		N/A
29.3.2	Each layer of material withstand the electric strength test of 16.3 for supplementary insulation		N/A
	Supplementary insulation consist of at least 2 layers		N/A
	Reinforced insulation consist of at least 3 layers		N/A
29.3.3	The insulation is subjected to the dry heat test Bb of IEC 60068-2-2, followed by		N/A
	the electric strength test of 16.3		N/A
	If the temperature rise during the tests of Clause 19 does not exceed the value specified in Table 3, the test of IEC 60068-2-2 is not carried out		N/A
29.3.4	Thickness of accessible parts of reinforced insulation consisting of a single layer not less than specified in Table 19		N/A
30	RESISTANCE TO HEAT AND FIRE		--
30.1	External parts of non-metallic material,		P
	parts supporting live parts, and		P
	parts of thermoplastic material providing supplementary or reinforced insulation		P
	sufficiently resistant to heat		P
	Ball-pressure test according to IEC 60695-10-2		P

IEC 60335-2-15			
Clause	Requirement + Test	Result - Remark	Verdict
	External parts tested at 40 °C plus the maximum temperature rise determined during the test of Clause 11, or at 75 °C, whichever is the higher; temperature (°C)..... :	(see appended Table 30.1)	P
	Parts supporting live parts tested at 40 °C plus the maximum temperature rise determined during the test of Clause 11, or at 125 °C, whichever is the higher; temperature (°C)..... :	Certified switch	P
	Parts of thermoplastic material providing supplementary or reinforced insulation tested at 25 °C plus the maximum temperature rise determined during Clause 19, if higher; temperature (°C) :		N/A
	For coffee makers, egg boilers, kettles and steam cookers, the temperature rises occurring during the tests of 19.4, 19.5 and 19.101 are not taken into account (IEC 60335-2-15)		N/A
30.2	Parts of non-metallic material resistant to ignition and spread of fire		P
	This requirement does not apply to:		--
	parts having a mass not exceeding 0,5 g, provided the cumulative effect is unlikely to propagate flames that originate inside the appliance by propagating flames from one part to another, or		N/A
	decorative trims, knobs and other parts unlikely to be ignited or to propagate flames that originate inside the appliance		P
	Compliance checked by the test of 30.2.1, and in addition:		N/A
	- for attended appliances, 30.2.2 applies;		P
	- for unattended appliances, 30.2.3 applies		N/A
	For appliances for remote operation, 30.2.3 applies		N/A
	For base material of printed circuit boards, 30.2.4 applies		P
	For water distillers, appliances incorporating a delayed start timer and appliances intended to maintain liquid or food at a particular temperature, 30.2.3 applies (IEC 60335-2-15)		P
	For other appliances, 30.2.2 applies (IEC 60335-2-15)		N/A
30.2.1	Parts of non-metallic material subjected to the glow-wire test of IEC 60695-2-11 at 550 °C	(see appended Table 30.2)	P
	However, test not carried out if the material is classified as having a glow-wire flammability index according to IEC 60695-2-12 of at least 550 °C, or		N/A

IEC 60335-2-15			
Clause	Requirement + Test	Result - Remark	Verdict
	the material is classified at least HB40 according to IEC 60695-11-10		N/A
	Parts for which the glow-wire test cannot be carried out need to meet the requirements in ISO 9772 for material classified HBF		N/A
30.2.2	Appliances operated while attended, parts of non-metallic material supporting current-carrying connections, and		N/A
	parts of non-metallic material within a distance of 3 mm of such connections,		N/A
	subjected to the glow-wire test of IEC 60695-2-11 with appropriate severity level:		N/A
	- 750 °C, for connections carrying a current exceeding 0,5 A during normal operation,		N/A
	- 650 °C, for other connections		N/A
	Glow-wire applied to an interposed shielding material, if relevant		N/A
	The glow-wire test is not carried out on parts of material classified as having a glow-wire flammability index according to IEC 60695-2-12 of at least:		--
	- 750 °C, for connections carrying a current exceeding 0,5 A during normal operation,		N/A
	- 650 °C, for other connections		N/A
	The glow-wire test is also not carried out on small parts. These parts are to:		--
	- comprise material having a glow-wire flammability index of at least 750 °C, or 650 °C as appropriate, or		N/A
	- comply with the needle-flame test of Annex E, or		N/A
	- comprise material classified as V-0 or V-1 according to IEC 60695-11-10		N/A
	Glow-wire test not applicable to conditions as specified		N/A
30.2.3	Appliances operated while unattended, tested as specified in 30.2.3.1 and 30.2.3.2		P
	The tests are not applicable to conditions as specified		N/A
30.2.3.1	Parts of non-metallic material supporting connections carrying a current exceeding 0,2 A during normal operation, and		P
	parts of non-metallic material, other than small parts, within a distance of 3 mm,		P
	subjected to the glow-wire test of IEC 60695-2-11 with a test severity of 850 °C		P

IEC 60335-2-15			
Clause	Requirement + Test	Result - Remark	Verdict
	Glow-wire applied to an interposed shielding material, if relevant		N/A
	The glow-wire test is not carried out on parts of material classified as having a glow-wire flammability index according to IEC 60695-2-12 of at least 850 °C		N/A
30.2.3.2	Parts of non-metallic material supporting connections, and		P
	parts of non-metallic material within a distance of 3 mm,		P
	subjected to the glow-wire test of IEC 60695-2-11 with appropriate severity level:		P
	- 750 °C, for connections carrying a current exceeding 0,2 A during normal operation,		P
	- 650 °C, for other connections		P
	Glow-wire applied to an interposed shielding material, if relevant		N/A
	However, the glow-wire test of 750 °C or 650 °C as appropriate, is not carried out on parts of material fulfilling both or either of the following classifications:		--
	- a glow-wire ignition temperature according to IEC 60695-2-13 of at least:		N/A
	<ul style="list-style-type: none"> • 775 °C, for connections carrying a current exceeding 0,2 A during normal operation, 		N/A
	<ul style="list-style-type: none"> • 675 °C, for other connections 		N/A
	- a glow-wire flammability index according to IEC 60695-2-12 of at least:		N/A
	- 750 °C, for connections carrying a current exceeding 0,2 A during normal operation,		N/A
	- 650 °C, for other connections		N/A
	The glow-wire test is also not carried out on small parts. These parts are to:		--
	- comprise material having a glow-wire ignition temperature of at least 775 °C or 675 °C as appropriate, or		N/A
	- comprise material having a glow-wire flammability index of at least 750 °C or 650 °C as appropriate, or		N/A
	- comply with the needle-flame test of Annex E, or		N/A
	- comprise material classified as V-0 or V-1 according to IEC 60695-11-10		N/A
	The consequential needle-flame test of Annex E applied to non-metallic parts that encroach within the vertical cylinder placed above the centre of the connection zone and on top of the non-metallic parts supporting current-carrying connections, and parts of non-metallic material within a distance of 3 mm of such connections if these parts are those:		--

IEC 60335-2-15			
Clause	Requirement + Test	Result - Remark	Verdict
	- parts that withstood the glow-wire test of IEC 60695-2-11 of 750 °C or 650 °C as appropriate, but produce a flame that persist longer than 2 s, or		N/A
	- parts that comprised material having a glow-wire flammability index of at least 750 °C or 650 °C as appropriate, or		N/A
	- small parts, that comprised material having a glow-wire flammability index of at least 750 °C or 650 °C as appropriate, or		N/A
	- small parts for which the needle-flame test of Annex E was applied, or		N/A
	- small parts for which a material classification of V-0 or V-1 was applied		N/A
	However, the consequential needle-flame test is not carried out on non-metallic parts, including small parts, within the cylinder that are:		--
	- parts having a glow-wire ignition temperature of at least 775 °C or 675 °C as appropriate, or		N/A
	- parts comprising material classified as V-0 or V-1 according to IEC 60695-11-10, or		N/A
	- parts shielded by a flame barrier that meets the needle-flame test of Annex E or that comprises material classified as V-0 or V-1 according to IEC 60695-11-10		N/A
30.2.4	Base material of printed circuit boards subjected to the needle-flame test of Annex E	(see appended Table 30.2/30.4)	P
	Test not applicable to conditions as specified..... :		N/A
31	RESISTANCE TO RUSTING		--
	Relevant ferrous parts adequately protected against rusting		P
	Tests specified in part 2 when necessary		N/A
32	RADIATION, TOXICITY AND SIMILAR HAZARDS		--
	Appliance does not emit harmful radiation or present a toxic or similar hazard due to their operation in normal use		P
	Compliance is checked by the limits or tests specified in part 2, if relevant		N/A
A	ANNEX A (INFORMATIVE) ROUTINE TESTS		--
	Description of routine tests to be carried out by the manufacturer		N/A
B	ANNEX B (NORMATIVE) APPLIANCES POWERED BY RECHARGEABLE BATTERIES THAT ARE RECHARGED IN THE APPLIANCE		--

IEC 60335-2-15			
Clause	Requirement + Test	Result - Remark	Verdict
	The following modifications to this standard are applicable for appliances powered by batteries that are recharged in the appliance		N/A
	Three forms of construction covered:		--
	a) Appliance supplied directly from the supply mains or a renewable energy source, the battery charging circuitry and other supply unit circuitry incorporated within the appliance		N/A
	b) The part of the appliance incorporating the battery is supplied from the supply mains or a renewable energy source, via a detachable supply unit. The battery charging circuitry is incorporated within the part of the appliance containing the battery		N/A
	c) The part of the appliance incorporating the battery is supplied from the supply mains or a renewable energy source, via a detachable supply unit. The battery charging circuitry is incorporated within the detachable supply unit		N/A
3.1.9	Appliance operated under the following conditions:		--
	- the appliance, supplied by its fully charged battery, operated as specified in relevant part 2;		N/A
	- the battery is charged, the battery being initially discharged to such an extent that the appliance cannot operate;		N/A
	- if possible, the appliance is supplied from the supply mains through its battery charger, the battery being initially discharged to such an extent that the appliance cannot operate. The appliance is operated as specified in relevant part 2;		N/A
	- if the appliance incorporates inductive coupling between two parts that are detachable from each other, the appliance is supplied from the supply mains with the detachable part removed		N/A
3.6.2	Part to be removed in order to discard the battery is not considered to be detachable		N/A
5.B.101	Appliances supplied from the supply mains tested as specified for motor-operated appliances		N/A
7.1	Battery compartment for batteries intended to be replaced by the user, marked with battery voltage (V) and polarity of the terminals :		N/A
	The positive terminal indicated by symbol IEC 60417-5005 and the negative terminal by symbol IEC 60417-5006		N/A
	Appliances intending to be supplied from a detachable supply unit marked with symbol IEC 60417-6181 and its type reference along with symbol ISO 7000-0790 (2004-01), or		N/A

IEC 60335-2-15			
Clause	Requirement + Test	Result - Remark	Verdict
	use only with <model designation> supply unit ... :		N/A
7.6	Additional symbols		N/A
7.12	The instructions give information regarding charging		N/A
	Instructions for appliances incorporating batteries intended to be replaced by the user include required information		N/A
	Details about how to remove batteries containing materials hazardous to the environment given		N/A
	Instructions for appliances containing non-user-replaceable batteries state the substance of the following:		--
	This appliance contains batteries that are only replaceable by skilled persons		N/A
	Instructions for appliances containing non-replaceable batteries shall state the substance of the following:		--
	This appliance contains batteries that are non-replaceable		N/A
	For appliances intending to be supplied from a detachable supply unit for the purposes of recharging the battery, the type reference of the detachable supply unit is stated along with the following:		--
	WARNING: For the purposes of recharging the battery, only use the detachable supply unit provided with this appliance		N/A
	If the symbol for detachable supply unit is used, its meaning is explained		N/A
7.15	Markings placed on the part of the appliance connected to the supply mains		N/A
	The type reference of the detachable supply unit is placed in close proximity to the symbol		N/A
8.2	Appliances having batteries that according to the instruction may be replaced by the user need only have basic insulation between live parts and the inner surface of the battery compartment		N/A
	If the appliance can be operated without batteries, double or reinforced insulation required		N/A
11.7	The battery is charged for the period stated in the instructions or 24 h		N/A
11.8	Temperature rise of the battery surface does not exceed the limit in the battery manufacturer's specification; measured (K); limit (K)		N/A
	If no limit specified, the temperature rise does not exceed 20 K; measured (K)		N/A
19.1	Appliances subjected to tests of 19.B.101, 19.B.102 and 19.B.103		N/A

IEC 60335-2-15			
Clause	Requirement + Test	Result - Remark	Verdict
19.10	Not applicable		N/A
19.B.101	Appliances supplied at rated voltage for 168 h, the battery being continually charged		N/A
19.B.102	For appliances having batteries that can be removed without the aid of a tool, short-circuit of the terminals of the battery, the battery being fully charged		N/A
19.B.103	Appliances having batteries replaceable by the user supplied at rated voltage under normal operation with the battery removed or in any position allowed by the construction		N/A
19.13	The battery does not rupture or ignite		N/A
21.B.101	Appliances having pins for insertion into socket-outlets have adequate mechanical strength		N/A
	Part of the appliance incorporating the pins subjected to the free fall test, procedure 2, of IEC 60068-2-31, the number of falls being:		--
	- 100, if the mass of the part does not exceed 250 g (g)		N/A
	- 50, if the mass of the part exceeds 250 g		N/A
	After the test, the requirements of 8.1, 15.1.1, 16.3 and Clause 29 are met		N/A
22.3	Appliances having pins for insertion into socket-outlets tested as fully assembled as possible		N/A
25.13	An additional lining or bushing not required for interconnection cords in class III appliances or class III constructions operating at safety extra-low voltage not containing live parts		N/A
30.2	For parts of the appliance connected to the supply mains during the charging period, 30.2.3 applies		N/A
	For other parts, 30.2.2 applies		N/A
C	ANNEX C (NORMATIVE) AGEING TEST ON MOTORS		--
	Tests, as described, carried out when doubt with regard to the temperature classification of the insulation of a motor winding		N/A
	Test conditions as specified		N/A
	The value of p in Table C.1 is 2000 (IEC 60335-2-15)		N/A
D	ANNEX D (NORMATIVE) THERMAL MOTOR PROTECTORS		--
	Applicable to appliances having motors that incorporate thermal motor protectors necessary for compliance with the standard		N/A
	Test conditions as specified		N/A

IEC 60335-2-15			
Clause	Requirement + Test	Result - Remark	Verdict
E	ANNEX E (NORMATIVE) NEEDLE-FLAME TEST		--
	Needle-flame test carried out in accordance with IEC 60695-11-5, with the following modifications:		--
7	Severities		--
	The duration of application of the test flame is 30 s ±1 s		P
9	Test procedure		--
9.1	The specimen so arranged that the flame can be applied to a vertical or horizontal edge as shown in the examples of Figure 1		P
9.2	The first paragraph does not apply		P
	If possible, the flame is applied at least 10 mm from a corner		P
9.3	The test is carried out on one specimen		P
	If the specimen does not withstand the test, the test may be repeated on two additional specimens, both withstanding the test		P
11	Evaluation of test results		--
	The duration of burning not exceeding 30 s		N/A
	However, for printed circuit boards, the duration of burning not exceeding 15 s		P
F	ANNEX F (NORMATIVE) CAPACITORS		--
	Capacitors likely to be permanently subjected to the supply voltage, and used for radio interference suppression or voltage dividing, comply with the following clauses of IEC 60384-14, with the following modifications:		--
1.5	Terms and definitions		--
1.5.3	Class X capacitors tested according to subclass X2		N/A
1.5.4	This sub-clause is applicable		N/A
1.6	Marking		--
	Items a) and b) are applicable		N/A
3.4	Approval testing		--
3.4.3.2	Table 3 is applicable as described		N/A
4.1	Visual examination and check of dimensions		--
	This sub-clause is applicable		N/A
4.2	Electrical tests		--
4.2.1	This sub-clause is applicable		N/A
4.2.5	This sub-clause is applicable		N/A
4.2.5.2	Only Table 11 is applicable		N/A

IEC 60335-2-15			
Clause	Requirement + Test	Result - Remark	Verdict
	Values for test A apply		N/A
	However, for capacitors in heating appliances the values for test B or C apply		N/A
4.12	Damp heat, steady state		--
	This sub-clause is applicable		N/A
	Only insulation resistance and voltage proof are checked		N/A
4.13	Impulse voltage		--
	This sub-clause is applicable		N/A
4.14	Endurance		--
	Sub-clauses 4.14.1, 4.14.3, 4.14.4 and 4.14.7 are applicable		N/A
4.14.7	Only insulation resistance and voltage proof are checked		N/A
	No visible damage		N/A
4.17	Passive flammability test		--
	This sub-clause is applicable		N/A
4.18	Active flammability test		--
	This sub-clause is applicable		N/A
G	ANNEX G (NORMATIVE) SAFETY ISOLATING TRANSFORMERS		--
	The following modifications to this standard are applicable for safety isolating transformers:		--
7	Marking and instructions		--
7.1	Transformers for specific use marked with:		--
	- name, trademark or identification mark of the manufacturer or responsible vendor		N/A
	- model or type reference		N/A
17	Overload protection of transformers and associated circuits		--
	Fail-safe transformers comply with Sub-clause 15.5 of IEC 61558-1		N/A
22	Construction		--
	Sub-clauses 19.1 and 19.1.2 of IEC 61558-2-6 are applicable		N/A
29	Clearances, creepage distances and solid insulation		--
29.1, 29.2, 29.3	The distances specified in items 2a, 2c and 3 in Table 13 of IEC 61558-1 apply		N/A
	For insulated winding wires complying with Sub-clause 19.12.3 of IEC 61558-1 there are no requirements for clearances or creepage distances		N/A

IEC 60335-2-15			
Clause	Requirement + Test	Result - Remark	Verdict
	For windings providing reinforced insulation, the distance specified in item 2c of Table 13 of IEC 61558-1 is not assessed		N/A
	For safety isolating transformers subjected to periodic voltages with a frequency exceeding 30 kHz, the clearances, creepage distances and solid insulation values specified in IEC 60664-4 are applicable, if greater than the values specified in items 2a, 2c and 3 in Table 13 of IEC 61558-1		N/A
H	ANNEX H (NORMATIVE) SWITCHES		--
	Switches comply with the following clauses of IEC 61058-1, as modified below:		--
	The tests of IEC 61058-1 carried out under the conditions occurring in the appliance		P
	Before being tested, switches are operated 20 times without load		P
8	Marking and documentation		--
	Switches are not required to be marked		P
	However, a switch that can be tested separately from the appliance marked with the manufacturer's name or trade mark and the type reference		N/A
13	Mechanism		--
	The tests may be carried out on a separate sample		P
15	Insulation resistance and dielectric strength		--
15.1	Not applicable		N/A
15.2	Not applicable		N/A
15.3	Applicable for full disconnection and micro-disconnection		P
17	Endurance		--
	Compliance is checked on three separate appliances or switches		P
	For 17.2.4.4, the number of cycles declared according to 7.1.4 is 10 000, unless		P
	otherwise specified in 24.1.3 of the relevant part 2 of IEC 60335..... :		N/A
	Switches for operation under no load and which can be operated only by a tool, and		N/A
	switches operated by hand that are interlocked so that they cannot be operated under load,		N/A
	are not subjected to the tests		N/A
	However, switches without this interlock are subjected to the test of 17.2.4.4 for 100 cycles of operation		N/A

IEC 60335-2-15			
Clause	Requirement + Test	Result - Remark	Verdict
	Sub-clauses 17.2.2 and 17.2.5.2 not applicable		P
	The ambient temperature during the test is that occurring in the appliance during the test of Clause 11 in IEC 60335-1		P
	The temperature rise of the terminals not more than 30 K above the temperature rise measured in Clause 11 of IEC 60335-1 (K)		P
20	Clearances, creepage distances, solid insulation and coatings of rigid printed board assemblies		--
	Clause 20 is applicable to clearances across full disconnection and micro-disconnection		P
	It is also applicable to creepage distances for functional insulation, across full disconnection and micro-disconnection, as stated in Table 24		P
I	ANNEX I (NORMATIVE) MOTORS HAVING BASIC INSULATION THAT IS INADEQUATE FOR THE RATED VOLTAGE OF THE APPLIANCE		--
	The following modifications to this standard are applicable for motors having basic insulation that is inadequate for the rated voltage of the appliance:		--
8	Protection against access to live parts		--
8.1	Metal parts of the motor are considered to be bare live parts		N/A
11	Heating		--
11.3	The temperature rise of the body of the motor is determined instead of the temperature rise of the windings		N/A
11.8	The temperature rise of the body of the motor, where in contact with insulating material, not exceeding values in Table 3 for the relevant insulating material		N/A
16	Leakage current and electric strength		--
16.3	Insulation between live parts of the motor and its other metal parts is not subjected to the test		N/A
19	Abnormal operation		--
19.1	The tests of 19.7 to 19.9 are not carried out		N/A
19.1.101	Appliance operated at rated voltage with each of the following fault conditions:		--
	- short circuit of the terminals of the motor, including any capacitor incorporated in the motor circuit;		N/A
	- short circuit of each diode of the rectifier;		N/A
	- open circuit of the supply to the motor;		N/A
	- open circuit of any parallel resistor, the motor being in operation		N/A

IEC 60335-2-15			
Clause	Requirement + Test	Result - Remark	Verdict
	Only one fault simulated at a time, the tests carried out consecutively		N/A
22	Construction		--
22.1.101	For class I appliances incorporating a motor supplied by a rectifier circuit, the d.c. circuit being insulated from accessible parts of the appliance by double or reinforced insulation		N/A
	Compliance checked by the tests specified for double and reinforced insulation		N/A
J	ANNEX J (NORMATIVE) COATED PRINTED CIRCUIT BOARDS		--
	Testing of protective coatings of printed circuit boards carried out in accordance with IEC 60664-3 with the following modifications:		--
5.7	Conditioning of the test specimens		--
	When production samples are used, three samples of the printed circuit board are tested		N/A
5.7.1	Cold		--
	The test is carried out at -25 °C		N/A
5.7.3	Rapid change of temperature		--
	Severity 1 is specified		N/A
5.9	Additional tests		--
	This subclause is not applicable		N/A
K	ANNEX K (NORMATIVE) OVERVOLTAGE CATEGORIES		--
	The information on overvoltage categories is extracted from IEC 60664-1		P
	Overtoltage category is a numeral defining a transient overvoltage condition		P
	Equipment of overvoltage category IV is for use at the origin of the installation		N/A
	Equipment of overvoltage category III is equipment in fixed installations and for cases where the reliability and the availability of the equipment is subject to special requirements		N/A
	Equipment of overvoltage category II is energy consuming equipment to be supplied from the fixed installation		P
	If such equipment is subjected to special requirements with regard to reliability and availability, overvoltage category III applies		N/A
	Equipment of overvoltage category I is equipment for connection to circuits in which measures are taken to limit transient overvoltages to an appropriate low level		N/A

IEC 60335-2-15			
Clause	Requirement + Test	Result - Remark	Verdict
L	ANNEX L (INFORMATIVE) GUIDANCE FOR THE MEASUREMENT OF CLEARANCES AND CREEPAGE DISTANCES		--
	Information for the determination of clearances and creepage distances		P
M	ANNEX M (NORMATIVE) POLLUTION DEGREE		--
	The information on pollution degrees is extracted from IEC 60664-1		P
	Pollution		--
	The microenvironment determines the effect of pollution on the insulation, taking into account the macroenvironment		P
	Means may be provided to reduce pollution at the insulation by effective enclosures or similar		P
	Minimum clearances specified where pollution may be present in the microenvironment		P
	Degrees of pollution in the microenvironment		---
	For evaluating creepage distances, the following degrees of pollution in the microenvironment are established:		--
	- pollution degree 1: no pollution or only dry, non-conductive pollution occurs. The pollution has no influence		N/A
	- pollution degree 2: only non-conductive pollution occurs, except that occasionally a temporary conductivity caused by condensation is to be expected		N/A
	- pollution degree 3: conductive pollution occurs or dry non-conductive pollution occurs that becomes conductive due to condensation that is to be expected		P
	- pollution degree 4: the pollution generates persistent conductivity caused by conductive dust or by rain or snow		N/A
N	ANNEX N (NORMATIVE) PROOF TRACKING TEST		--
	The proof tracking test is carried out in accordance with IEC 60112 with the following modifications:		--
7	Test apparatus		--
7.3	Test solutions		--
	Test solution A is used		P
10	Determination of proof tracking index (PTI)		--
10.1	Procedure		--
	The proof voltage is 100 V, 175 V, 400 V or 600 V.:	175 V	P

IEC 60335-2-15			
Clause	Requirement + Test	Result - Remark	Verdict
	The test is carried out on five specimens		P
	In case of doubt, additional test with proof voltage reduced by 25 V, the number of drops increased to 100		N/A
10.2	Report		N/A
	The report states if the PTI value was based on a test using 100 drops with a test voltage of (PTI-25) V		N/A
O	ANNEX O (INFORMATIVE) SELECTION AND SEQUENCE OF THE TESTS OF CLAUSE 30		--
	Description of tests for determination of resistance to heat and fire		P
P	ANNEX P (INFORMATIVE) GUIDANCE FOR THE APPLICATION OF THIS STANDARD TO APPLIANCES USED IN TROPICAL CLIMATES		--
	Modifications applicable for class 0 and 0I appliances having a rated voltage exceeding 150 V, intended to be used in countries having a warm damp equable climate and that are marked WDaE		--
	Modifications may also be applied to class I appliances having a rated voltage exceeding 150 V, intended to be used in countries having a warm damp equable climate and that are marked with symbol IEC 60417-6332 (2015-06), if liable to be connected to a supply mains that excludes the protective earthing conductor		--
5.7	The ambient temperature for the tests of Clauses 11 and 13 is 40 +3/0 °C		N/A
7.1	The appliance marked with symbol IEC 60417-6332 (2015-06)		N/A
7.6	[Symbol IEC 60417-6332 (2015-06)] tropical climate, as indicated		N/A
7.12	The instructions state that the appliance is to be supplied through a residual current device (RCD) having a rated residual operating current not exceeding 30 mA		N/A
	The instructions state that the appliance is considered to be suitable for use in countries having a warm damp equable climate, but may also be used in other countries		N/A
	If symbol IEC 60417-6332 is used, its meaning is explained		N/A
11.8	The values of Table 3 are reduced by 15 K		N/A
13.2	The leakage current for class I appliances not exceeding 0,5 mA (mA).....:		N/A
15.3	The value of t is 37 °C		N/A
16.2	The leakage current for class I appliances not exceeding 0,5 mA (mA).....:		N/A

IEC 60335-2-15			
Clause	Requirement + Test	Result - Remark	Verdict
19.13	The leakage current test of 16.2 is applied in addition to the electric strength test of 16.3		N/A
Q	ANNEX Q (INFORMATIVE) SEQUENCE OF TESTS FOR THE EVALUATION OF ELECTRONIC CIRCUITS		--
	Description of tests for appliances incorporating electronic circuits		N/A
R	ANNEX R (NORMATIVE) SOFTWARE EVALUATION		--
	Programmable electronic circuits requiring software incorporating measures to control the fault/error conditions specified in Table R.1 or R.2 validated in accordance with the requirements of this annex		N/A
R.1	Programmable electronic circuits using software		--
	Programmable electronic circuits requiring software incorporating measures to control the fault/error conditions specified in Table R.1 or R.2 constructed so that the software does not impair compliance with the requirements of this standard		N/A
R.2	Requirements for the architecture		--
	Programmable electronic circuits requiring software incorporating measures to control the fault/error conditions specified in Table R.1 or R.2 use measures to control and avoid software-related faults/errors in safety-related data and safety-related segments of the software		N/A
R.2.1.1	Programmable electronic circuits requiring software incorporating measures to control the fault/error conditions specified in Table R.2 have one of the following structures:		--
	- single channel with periodic self-test and monitoring;		N/A
	- dual channel (homogenous) with comparison;		N/A
	- dual channel (diverse) with comparison		N/A
	Programmable electronic circuits requiring software incorporating measures to control the fault/error conditions specified in Table R.1 have one of the following structures:		--
	- single channel with functional test;		N/A
	- single channel with periodic self-test;		N/A
	- dual channel without comparison		N/A
R.2.2	Measures to control faults/errors		--
R.2.2.1	When redundant memory with comparison is provided on two areas of the same component, the data in one area is stored in a different format from that in the other area		N/A

IEC 60335-2-15			
Clause	Requirement + Test	Result - Remark	Verdict
R.2.2.2	Programmable electronic circuits with functions requiring software incorporating measures to control the fault/error conditions specified in Table R.2 and that use dual channel structures with comparison, have additional fault/error detection means for any fault/errors not detected by the comparison		N/A
R.2.2.3	For programmable electronic circuits with functions requiring software incorporating measures to control the fault/error conditions specified in Table R.1 or R.2, means are provided for the recognition and control of errors in transmissions to external safety-related data paths		N/A
R.2.2.4	For programmable electronic circuits with functions requiring software incorporating measures to control the fault/error conditions specified in Table R.1 or R.2, the programmable electronic circuits incorporate measures to address the fault/errors in safety-related segments and data indicated in Table R.1 and R.2 as appropriate		N/A
R.2.2.5	For programmable electronic circuits with functions requiring software incorporating measures to control the fault/error conditions specified in Table R.1 or R.2, detection of a fault/error occur before compliance with Clause 19 is impaired		N/A
R.2.2.6	The software is referenced to relevant parts of the operating sequence and the associated hardware functions		N/A
R.2.2.7	Labels used for memory locations are unique		N/A
R.2.2.8	The software is protected from user alteration of safety-related segments and data		N/A
R.2.2.9	Software and safety-related hardware under its control is initialized and terminates before compliance with Clause 19 is impaired		N/A
R.3	Measures to avoid errors		--
R.3.1	General		--
	For programmable electronic circuits with functions requiring software incorporating measures to control the fault/error conditions specified in Table R.1 or R.2, the following measures to avoid systematic fault in the software are applied		--
	Software that incorporates measures used to control the fault/error conditions specified in Table R.2 is inherently acceptable for software required to control the fault/error conditions specified in Table R.1		N/A
R.3.2	Specification		--
R.3.2.1	Software safety requirements:		N/A
	The specification of the software safety requirements includes the descriptions listed		N/A

IEC 60335-2-15			
Clause	Requirement + Test	Result - Remark	Verdict
R.3.2.2	Software architecture		--
R.3.2.2.1	The specification of the software architecture includes the aspects listed - techniques and measures to control software faults/errors (refer to R.2.2); - interactions between hardware and software; - partitioning into modules and their allocation to the specified safety functions; - hierarchy and call structure of the modules (control flow); - interrupt handling; - data flow and restrictions on data access; - architecture and storage of data; - time-based dependencies of sequences and data		N/A
R.3.2.2.2	The architecture specification is validated against the specification of the software safety requirements by static analysis		N/A
R.3.2.3	Module design and coding		--
R.3.2.3.1	Based on the architecture design, software is suitably refined into modules		N/A
	Software module design and coding is implemented in a way that is traceable to the software architecture and requirements		N/A
R.3.2.3.2	Software code is structured		N/A
R.3.2.3.3	Coded software is validated against the module specification by static analysis		N/A
	The module specification is validated against the architecture specification by static analysis		N/A
R.3.3.3	Software validation		--
	The software is validated with reference to the requirements of the software safety requirements specification		N/A
	Compliance is checked by simulation of:		--
	- input signals present during normal operation,		N/A
	- anticipated occurrences,		N/A
	- undesired conditions requiring system action		N/A
	TABLE R.1^e – GENERAL FAULT/ERROR CONDITIONS		P

IEC 60335-2-15						
Clause	Requirement + Test		Result - Remark			Verdict
Component ^a	Fault/error	Acceptable measures ^{b, c}	Definitions	Document reference for applied measure	Document reference for applied test	Verdict
1 CPU 1.1 Registers	Stuck at	Functional test, or periodic self-test using either: - static memory test, or - word protection with single bit redundancy	H.2.16.5 H.2.16.6 H.2.19.6 H.2.19.8.2			N/A
1.2 VOID						N/A
1.3 Programme counter	Stuck at	Functional test, or periodic self-test, or independent time-slot monitoring, or logical monitoring of the programme sequence	H.2.16.5 H.2.16.6 H.2.18.10.4 H.2.18.10.2			N/A
2 Interrupt handling and execution	No interrupt or too frequent interrupt	Functional test, or time-slot monitoring	H.2.16.5 H.2.18.10.4			N/A
3 Clock	Wrong frequency (for quartz synchronized clock: harmonics/ sub-harmonics only)	Frequency monitoring, or time slot monitoring	H.2.18.10.1 H.2.18.10.4			N/A
4 Memory 4.1 Invariable memory	All single bit faults	Periodic modified checksum, or multiple checksum, or word protection with single bit redundancy	H.2.19.3.1 H.2.19.3.2 H.2.19.8.2			N/A

IEC 60335-2-15						
Clause	Requirement + Test		Result - Remark			Verdict
4.2 Variable memory	DC fault	Periodic static memory test, or word protection with single bit redundancy	H.2.19.6 H.2.19.8.2			N/A
4.3 Addressing (relevant to variable and invariable memory)	Stuck at	Word protection with single bit redundancy including the address	H.2.19.8.2			N/A
5 Internal data path	Stuck at	Word protection with single bit redundancy	H.2.19.8.2			N/A
5.1 VOID						N/A
5.2 Addressing	Wrong address	Word protection with single bit redundancy including the address	H.2.19.8.2			N/A
6 External communication	Hamming distance 3	Word protection with multi-bit redundancy, or CRC – single work, or transfer redundancy, or protocol test	H.2.19.8.1 H.2.19.4.1 H.2.18.2.2 H.2.18.14			N/A
6.1 VOID						N/A
6.2 VOID						N/A
6.3 Timing	Wrong point in time Wrong sequence	Time-slot monitoring, or scheduled transmission Time-slot and logical monitoring, or comparison of redundant communication channels by either: - reciprocal comparison - independent hardware comparator Logical monitoring, or time-slot monitoring, or scheduled transmission	H.2.18.10.4 H.2.18.18 H.2.18.10.3 H.2.18.15 H.2.18.3 H.2.18.10.2 H.2.18.10.4 H.2.18.18			N/A
7 Input/output periphery	Fault conditions specified in 19.11.2	Plausibility check	H.2.18.13			N/A
7.1 VOID						N/A

IEC 60335-2-15						
Clause	Requirement + Test			Result - Remark		Verdict
7.2 Analogy I/O						N/A
7.2.1 A/D- and D/A- converter	Fault conditions specified in 19.11.2	Plausibility check	H.2.18.13			
7.2.2 Analog multiplexer	Wrong addressing	Plausibility check	H.2.18.13			N/A
8 VOID						N/A
9 Custom chips ^d e.g. ASIC, GAL, gate array	Any output outside the static and dynamic functional specification	Periodic self-test	H.2.16.6			N/A
<p>NOTE A Stuck-at fault model denotes a fault model representing an open circuit or a non-varying signal level. A DC fault model denotes a stuck-at fault model incorporating short circuit between signal lines.</p> <p>a) For fault/error assessment, some components are divided into their sub-functions. b) For each sub-function in the table, the Table R.2 measure will cover the software fault/error. c) Where more than one measure is given for a sub-function, these are alternatives. d) To be divided as necessary by the manufacturer into sub-functions. e) Table R.1 is applied according to the requirements of R.1 to R.2.2.9 inclusive.</p>						

IEC 60335-2-15			
Clause	Requirement + Test	Result - Remark	Verdict
S	ANNEX S (NORMATIVE) BATTERY OPERATED APPLIANCES POWERED BY BATTERIES THAT ARE NON-RECHARGEABLE OR NOT RECHARGED IN THE APPLIANCE		--
	The following modifications to this standard are applicable for battery-operated appliances where the batteries are either non-rechargeable (primary batteries), or		N/A
	rechargeable batteries (secondary batteries) that are not recharged in the appliance		N/A
5.8.1	If the supply terminals for the connection of the battery have no indication of polarity, the more unfavourable polarity is applied		N/A
5.S.101	Appliances intended for use with a battery box are tested with the battery box supplied with the appliance or with the battery box recommended in the instructions		N/A
5.S.102	Appliances are tested as motor-operated appliances.		N/A
7.1	Appliances marked with the battery voltage (V) and the polarity of the terminals, unless.....: :		N/A
	the polarity is irrelevant		N/A
	Appliances also marked with:		--
	– name, trade mark or identification mark of the manufacturer or responsible vendor: :		N/A
	– model or type reference: :		N/A
	– IP number according to degree of protection against ingress of water, other than IPX0: :		N/A
	– type reference of battery or batteries: :		N/A
	If relevant, the positive terminal is indicated by the symbol IEC 60417-5005 and the negative terminal by the symbol IEC 60417-5006		N/A
	If appliances use more than one battery, they are marked to indicate correct polarity connection of the batteries		N/A
7.6	Additional symbols		N/A
7.12	The instructions contain the following, as applicable:		--
	– the types of batteries that may be used: :		N/A
	– how to remove and insert the batteries;		N/A
	– non-rechargeable batteries are not to be recharged;		N/A

IEC 60335-2-15			
Clause	Requirement + Test	Result - Remark	Verdict
	– rechargeable batteries are to be removed from the appliance before being charged;		N/A
	– different types of batteries or new and used batteries are not to be mixed;		N/A
	– batteries are to be inserted with the correct polarity;		N/A
	– exhausted batteries are to be removed from the appliance and safely disposed of;		N/A
	– if the appliance is to be stored unused for a long period, the batteries are removed;		N/A
	– the supply terminals are not to be short-circuited		N/A
11.5	Appliances are supplied with the most unfavourable supply voltage between		--
	– 0,55 and 1,0 times the battery voltage, if the appliance can be used with non-rechargeable batteries		N/A
	– 0,75 and 1,0 times battery voltage, if the appliance is designed for use with rechargeable batteries only		N/A
	The values specified in Table S.101 for the internal resistance per cell of the battery is taken into account		N/A
19.1	The tests are carried out with the battery fully charged unless otherwise specified		N/A
19.13	The battery does not rupture or ignite		N/A
19.S.101	Appliances are supplied with the voltage specified in 11.5. The supply terminals having an indication of polarity are connected to the opposite polarity, unless		N/A
	such a connection is unlikely to occur due to the construction of the appliance		N/A
19.S.102	For appliances with provision for multiple batteries, one or more of the batteries are reversed and the appliance is operated, if reversal of batteries is allowed by the construction		N/A
25.5	The flexible leads or flexible cord used to connect an external battery or battery box in is connected to the appliance by a type X attachment		N/A
25.13	This requirement is not applicable to the flexible leads or flexible cord connecting external batteries or a battery box with an appliance		N/A
25.S.101	Appliances have suitable means for connection of the battery. If the type of battery is marked on the appliance, the means of connection is suitable for this type of battery		N/A

IEC 60335-2-15			
Clause	Requirement + Test	Result - Remark	Verdict
26.5	Terminal devices in an appliance for the connection of the flexible leads or flexible cord connecting an external battery or battery box are so located or shielded that there is no risk of accidental connection between supply terminals		N/A
30.2.3.2	There is no battery in the area of the vertical cylinder used for the consequential needle flame test, unless		N/A
	the battery is shielded by a barrier that meets the needle flame test of Annex E, or		N/A
	that comprises material classified as V-0 or V-1 according to IEC 60695-11-10		N/A
T	ANNEX T (NORMATIVE) UV-C RADIATION EFFECT ON NON-METALLIC MATERIALS		--
	Requirements for non-metallic materials subject to direct or reflected UV-C radiation exposure and whose mechanical and electrical properties are relied upon for compliance with the		N/A
	Does not apply to glass, ceramic and similar materials		N/A
	Tested as specified in ISO 4892-1 and ISO 4892-2, with the following modifications:		--
	Modifications to ISO 4892-1:		--
5.1	Light source		--
5.1.6	The UV-C emitter is a low pressure mercury lamp with a quartz envelope having a continuous spectral irradiance of 10 W/m ² at 254 nm		N/A
	Sub-clause 5.1.6.1 and Table 1 are not applicable		N/A
5.2	Temperature		--
5.2.4	The black-panel temperature shall be 63 °C ±3 °C		N/A
5.3	Humidity and wetting		--
5.3.1	Humidification of the chamber air is specified in part 2 when necessary		N/A
9	Test report		--
	This clause is not applicable		N/A
	Modifications to ISO 4892-2:		--
7	Procedure		--
7.1	General		--
	At least three test specimens are tested		N/A
	Ten samples of internal wiring is tested		N/A
7.2	Mounting the test specimens		--
	The specimens are attached to the specimen holders such that they are not subject to any stress		N/A

IEC 60335-2-15			
Clause	Requirement + Test	Result - Remark	Verdict
7.3	Exposure		--
	Apparatus prepared as specified		N/A
	The test specimens and, if used, the irradiance-measuring instrument are exposed for 1 000 h		N/A
7.4	Measurement of radiant exposure		--
	If used, a radiometer is mounted and calibrated such that it measures the irradiance at the exposed surface of the test specimen		N/A
7.5	Determination of changes in properties after exposure		--
	Material properties and test methods for parts providing mechanical support or impact resistance as specified in Table T.1		N/A
	Material properties and test method for electrical insulation of internal wiring as specified in Table T.2		N/A
8	Exposure report		--
	This clause is not applicable		N/A

IEC 60335-2-15					
Clause	Requirement + Test	Result - Remark			Verdict
10.1	TABLE: Power input deviation				P
Input deviation of/at:	P rated (W)	P measured (W)	ΔP (W, %)	Required ΔP (W, %)	Remark
230V	220	212,3	-3,5%	+5%, -10 %	RC03-Y
230V	300	300,2	+0,1%	+5%, -10 %	RC06A-GX3
230V	350	338,5	-3,3%	+5%, -10 %	RC06B-AY3
230V	400	404,7	+1,2%	+5%, -10 %	RC10A-IX3
230V	450	441,7	-1,8%	+5%, -10 %	RC10B-LY3
230V	500	498,6	-0,3%	+5%, -10 %	RC15A-GX3
230V	550	538,9	-2,0%	+5%, -10 %	RC15B-GY2
230V	700	701,2	+0,2%	+5%, -10 %	RC18A-OX1
230V	650	649,2	-1,2%	+5%, -10 %	RC18B-PX3
230V	750	738,7	-1,5%	+5%, -10 %	RC18C-MX2
230V	900	903,1	+0,3%	+5%, -10 %	RC22A-JX3
230V	850	841,5	-1,0%	+5%, -10 %	RC22B-GY1
230V	1000	988,9	-1,1%	+5%, -10 %	RC28A-NX3
230V	950	943,7	-0,7%	+5%, -10 %	RC28B-PX3
230V	1300	1277,3	-1,7%	+5%, -10 %	RC36A-AY3
230V	1250	1247,3	-0,2%	+5%, -10 %	RC36B-AY3
230V	1600	1583,2	-1,1%	+5%, -10 %	RC42A-FY3
230V	1550	1531,8	-1,2%	+5%, -10 %	RC42B-BY3
230V	2000	1958,3	-2,1%	+5%, -10 %	RC56A-AY3
230V	1950	1951,4	+0,1%	+5%, -10 %	RC56B-AY3
230V	2200	2196,7	-0,2%	+5%, -10 %	RC78A-FY3
230V	2250	2182,5	-3,0%	+5%, -10 %	RC78B-BY3
230V	2500	2493,6	-0,3%	+5%, -10 %	RC80A-EY3
230V	2250	2146,3	-4,6%	+5%, -10 %	RC80B-CY3
230V	2800	2803,4	+0,1%	+5%, -10 %	RC85A-DY3
230V	2650	2534,8	-4,3%	+5%, -10 %	RC85B-AY3
230V	3000	2977,3	-0,8%	+5%, -10 %	RC100A-FY3
230V	3200	3105,6	-3,0%	+5%, -10 %	RC100B-FY3
230V	3500	3425,5	-2,1%	+5%, -10 %	RC120A-AY2
230V	3250	3129,7	-3,7%	+5%, -10 %	RC120B-DY3
230V	350	341,6	-2,4%	+5%, -10 %	SRC06S1-WPY3
230V	450	451,2	+0,3%	+5%, -10 %	SRC10C1-mVX3

IEC 60335-2-15						
Clause	Requirement + Test			Result - Remark		Verdict
230V	500	489,5	-2,1%	+5%, -10 %	SRC15C-sPX1	
230V	700	698,1	-0,3%	+5%, -10 %	SRC18C - qWY2	
230V	850	846,2	-0,4%	+5%, -10 %	SRC22C1-tVY3	
230V	1000	987,5	-1,3%	+5%, -10 %	SRC28S-WPY3	
230V	400	396,7	-0,8%	+5%, -10 %	DRC10S1-GWA3	
230V	500	499,2	-0,2%	+5%, -10 %	DRC15C-iWG1	
230V	650	643,5	-1,0%	+5%, -10 %	DRC18S1-ePA3	
230V	1100	1083,5	-1,5%	+5%, -10 %	DRC28C-hWB3	
230V	1300	1286,8	-1,0%	+5%, -10 %	DRC36S-GPA3	
Supplementary information:						

10.2	TABLE: Current deviation					N/A
Current deviation of/at:	I rated (A)	I measured (A)	ΔI (A, %)	Required ΔI (A, %)	Remark	
Supplementary information:						

11.8a	TABLE: Heating test (Model RC03-X)			P
	Test voltage (V)..... :	257,4 V		—
	Ambient (°C)..... :	t ₁ = 22,1°C, t ₂ = 21,4°C		—
Thermocouple locations		Max. temperature rise measured, ΔT (K)	Max. temperature rise limit, ΔT (K)	
Inlet		43,2	45	
Ambient of mechanical switch		57,4	T85-25=60	
Internal wire near heating element		58,5	T180-25=155	
Ambient of micro switch		58,1	T85-25=60	
Silicone tube		88,0	T200-25=175	
Ambient of Temperature limiter		61,5	Ref.	
Control panel, inside / Lamp cover, inside		39,5	For Cl.30	
Lamp PCB		33,1	120	
Knob of control panel		45,0	60	
Handle		20,7	60	
Lid of cover		53,9	60	
Knob of mechanical switch		30,4	60	

IEC 60335-2-15			
Clause	Requirement + Test	Result - Remark	Verdict

Test corner (floor)		11,7	65
Supplementary information:			

11.8b	TABLE: Heating test (Model RC03-Y)		P
	Test voltage (V)..... :	257,1 V	—
	Ambient (°C)..... :	t ₁ = 16,6°C, t ₂ = 15,7°C	—
Thermocouple locations	Max. temperature rise measured, ΔT (K)	Max. temperature rise limit, ΔT (K)	
Power cord	34,9	50	
Ambient of mechanical switch	41,6	T85-25=60	
Internal wire near heating element	55,9	T180-25=155	
Silicone tube	64,3	T200-25=175	
Ambient of micro switch	38,4	T85-25=60	
Control panel, inside / Lamp cover, inside	32,2	For Cl.30	
Lamp PCB	35,1	120	
Knob of control panel	2,8	60	
Handle	21,3	60	
Lid of cover	48,7	60	
Knob of mechanical switch	17,8	60	
Test corner (floor)	4,3	65	
Supplementary information:			

11.8c	TABLE: Heating test (Model RC06B-AY3)		P
	Test voltage (V)..... :	261,6 V	—
	Ambient (°C)..... :	t ₁ = 24,5°C, t ₂ = 24,8°C	—
Thermocouple locations	Max. temperature rise measured, ΔT (K)	Max. temperature rise limit, ΔT (K)	
Power cord	44,6	50	
Internal wire near heating element	87,3	T180-25=155	
Ambient of thermostat	65,4	T220-25=195	
Ambient of Thermal cut-out	73,2	T210-25=185	
Ambient of micro switch	57,5	T85-25=60	
Knob of control panel	24,0	60	
Control panel, inside / Lamp cover, inside	54,8	For Cl.30	
Handle	24,8	60	
Lid of cover	27,0	60	

IEC 60335-2-15			
Clause	Requirement + Test	Result - Remark	Verdict
	Silicone tube	47,6	T200-25=175
	Ambient of mechanical switch	52,6	T85-25=60
	Knob of mechanical switch	26,3	60
	PCB	42,8	120
	Test corner (floor)	4,9	65
Supplementary information:			

11.8d	TABLE: Heating test (Model RC06B-AX3)		P
	Test voltage (V)..... :	263,5V	—
	Ambient (°C)..... :	t ₁ = 23,5°C, t ₂ = 24,3°C	—
Thermocouple locations		Max. temperature rise measured, ΔT (K)	Max. temperature rise limit, ΔT (K)
Inlet		43,7	45
Internal wire near heating element		92,9	T180-25=155
Ambient of thermostat		62,1	T220-25=195
Ambient of Thermal cut-out		62,8	T210-25=185
Ambient of micro switch		47,1	T85-25=60
Knob of control panel		46,3	60
Control panel, inside / Lamp cover, inside		46,9	For Cl.30
Handle		17,7	60
Lid of cover		22,0	60
Silicone tube		92,0	T200-25=175
Ambient of mechanical switch		48,2	T85-25=60
Knob of main switch		25,3	60
PCB		61,3	120
Test corner (floor)		18,0	65
Supplementary information:			

11.8e	TABLE: Heating test (Model RC28A-GY1)		P
	Test voltage (V)..... :	262,5 V	—
	Ambient (°C)..... :	t ₁ = 24,1°C, t ₂ = 21,7°C	—
Thermocouple locations		Max. temperature rise measured, ΔT (K)	Max. temperature rise limit, ΔT (K)
Power cord		34,3	50
Ambient of mechanical switch		51,5	T85-25=60
Internal wire near heating element		138,2	T180-25=155

IEC 60335-2-15			
Clause	Requirement + Test	Result - Remark	Verdict
	Silicone tube	114,3	T200-25=175
	Ambient of micro switch	59,0	T85-25=60
	Control panel, inside / Lamp cover, inside	29,2	For Cl,30
	Lamp PCB	26,3	120
	Knob of main switch	34,3	60
	Handle	6,5	60
	Lid of cover	27,6	60
	Knob of mechanical switch	6,5	60
	Test corner (floor)	27,7	65
Supplementary information:			

11.8f	TABLE: Heating test (Model RC28A-NX3)		P
	Test voltage (V)..... :	257,9 V	—
	Ambient (°C)..... :	t ₁ = 21,5°C, t ₂ = 22,3°C	—
Thermocouple locations	Max. temperature rise measured, ΔT (K)	Max. temperature rise limit, ΔT (K)	
Inlet	43,1	45	
Ambient of mechanical switch	37,9	T85-25=60	
Ambient of thermal cut-out	71,4	T210-25=185	
Internal wire near heating element	119,6	T180-25=155	
Silicone tube	108,7	T200-25=175	
Ambient of micro switch	58,7	T85-25=60	
Control panel, inside / Lamp cover, inside	31,2	For Cl.30	
Ambient of thermostat	78,4	T220-25=195	
Lamp PCB	19,4	120	
Knob of main switch	17,7	60	
Handle	31,2	60	
Lid of cover	13,0	60	
Knob of mechanical switch	2,2	60	
Test corner (floor)	14,2	65	
Supplementary information:			

IEC 60335-2-15			
Clause	Requirement + Test	Result - Remark	Verdict
11.8g	TABLE: Heating test (Model RC120A-AY2)		P
	Test voltage (V) :	261,5 V	—
	Ambient (°C) :	t ₁ = 17,4°C, t ₂ = 15,1°C	—
Thermocouple locations		Max. temperature rise measured, ΔT (K)	Max. temperature rise limit, ΔT (K)
Power cord		44,4	50
Ambient of mechanical switch		46,6	T85-25=60
Internal wire near heating element		76,6	T180-25=155
Ambient of thermostat		64,1	T220-25=195
Silicone tube		56,0	T200-25=175
Ambient of micro switch		64,3	For Annex H
Control panel, inside / Lamp cover, inside		32,3	For Cl.30
Lamp PCB		46,8	120
Knob of control panel		14,5	60
Handle		23,2	60
Lid of cover		17,8	60
Knob of mechanical switch		29,8	60
Test corner (floor)		3,8	65
Supplementary information:			

11.8h	TABLE: Heating test (Model DRC10S1-GWA3)		P
	Test voltage (V) :	256,1 V	—
	Ambient (°C) :	t ₁ = 22,8°C, t ₂ = 21,7°C	—
Thermocouple locations		Max. temperature rise measured, ΔT (K)	Max. temperature rise limit, ΔT (K)
Inlet		40,1	45
Ambient of mechanical switch		48,0	T85-25=60
Internal wire near heating element		64,3	T180-25=155
Ambient of thermal cut-out		42,5	T210-25=185
Ambient of thermostat		42,8	T220-25=195
Silicone tube		87,5	T200-25=175
Ambient of micro switch		42,2	T85-25=60
Control panel, inside / Lamp cover, inside		38,2	For Cl.30
Lamp PCB		14,6	120
Bottom plastic enclosure		62,2	For Cl.30

IEC 60335-2-15			
Clause	Requirement + Test	Result - Remark	Verdict
	Knob of control panel	41,8	60
	Handle	20,3	60
	Lid of cover	56,0	60
	Knob of mechanical switch	18,6	60
	Test corner (floor)	37,1	65
Supplementary information:			

11.8i	TABLE: Heating test (Model DRC36C-CWA3)		P
	Test voltage (V)..... :	260,2 V	—
	Ambient (°C)..... :	t ₁ = 22,2°C, t ₂ = 21,4°C	—
Thermocouple locations	Max. temperature rise measured, ΔT (K)	Max. temperature rise limit, ΔT (K)	
Inlet	41,2	45	
Ambient of mechanical switch	47,1	T85-25=60	
Ambient of thermal cut-out	63,1	T210-25=185	
Internal wire near heating element	69,5	T180-25=155	
Ambient of thermostat	50,9	T220-25=195	
Silicone tube	88,7	T200-25=175	
Ambient of micro switch	59,5	T85-25=60	
Control panel, inside / Lamp cover, inside	31,8	For Cl.30	
Lamp PCB	6,1	120	
Knob of control panel	47,7	60	
Handle	17,0	60	
Lid of cover	16,7	60	
Knob of mechanical switch	25,4	60	
Test corner (floor)	40,5	65	
Supplementary information:			

11.8j	TABLE: Heating test (Model DRC36S-GPA3)		P
	Test voltage (V)..... :	261,1 V	—
	Ambient (°C)..... :	t ₁ = 21,8°C, t ₂ = 20,6°C	—
Thermocouple locations	Max. temperature rise measured, ΔT (K)	Max. temperature rise limit, ΔT (K)	
Inlet	41,4	45	
Ambient of mechanical switch	47,3	T85-25=60	

IEC 60335-2-15			
Clause	Requirement + Test	Result - Remark	Verdict
	Ambient of thermal cut-out	50,9	T210-25=185
	Internal wire near heating element	70,0	T180-25=155
	Ambient of thermostat	59,7	T220-25=195
	Silicone tube	88,9	T200-25=175
	Ambient of micro switch	51,3	T85-25=60
	Control panel, inside / Lamp cover, inside	32,1	For Cl.30
	Lamp PCB	6,5	120
	Bottom plastic enclosure	54,7	For Cl.30
	Knob of control panel	48,0	60
	Handle	17,4	60
	Lid of cover	17,0	60
	Knob of mechanical switch	25,7	60
	Test corner (floor)	40,7	65
Supplementary information:			

11.8k	TABLE: Heating test (Model SRC06S-WPX3)		P
	Test voltage (V)..... :	257,4 V	—
	Ambient (°C)..... :	t ₁ = 21,6°C, t ₂ = 21,4°C	—
Thermocouple locations		Max. temperature rise measured, ΔT (K)	Max. temperature rise limit, ΔT (K)
Inlet		43,5	45
Ambient of mechanical switch		57,3	T85-25=60
Ambient of thermal cut-out		57,1	T210-25=185
Internal wire near heating element		58,8	T180-25=155
Ambient of micro switch		38,3	T85-25=60
Silicone tube		88,3	T200-25=175
Ambient of thermostat		61,8	T220-25=195
Control panel, inside / Lamp cover, inside		39,7	For Cl.30
Lamp PCB		33,4	120
Knob of control panel		23,7	60
Handle		21,0	60
Lid of cover		54,4	60
Knob of mechanical switch		30,7	60
Test corner (floor)		12,0	65
Supplementary information:			

IEC 60335-2-15			
Clause	Requirement + Test	Result - Remark	Verdict

11.8l	TABLE: Heating test (Model SRC06S1-WPY3)		P
	Test voltage (V)..... :	257,2 V	—
	Ambient (°C)..... :	t ₁ = 22,1°C, t ₂ = 21,2°C	—
Thermocouple locations	Max. temperature rise measured, ΔT (K)	Max. temperature rise limit, ΔT (K)	
Power cord	40,8	50	
Ambient of mechanical switch	54,6	T85-25=60	
Ambient of thermal cut-out	33,7	T210-25=185	
Internal wire near heating element	56,1	T180-25=155	
Ambient of micro switch	35,6	T85-25=60	
Silicone tube	85,6	T200-25=175	
Ambient of thermostat	59,2	T220-25=195	
Control panel, inside / Lamp cover, inside	37,0	For Cl.30	
Lamp PCB	30,7	120	
Knob of control panel	42,5	60	
Handle	18,3	60	
Lid of cover	51,7	60	
Knob of mechanical switch	28,0	60	
Test corner (floor)	9,3	65	
Supplementary information:			

11.8m	TABLE: Heating test (Model SRC28C-UWX3)		P
	Test voltage (V)..... :	259,8 V	—
	Ambient (°C)..... :	t ₁ = 22,7°C, t ₂ = 22,1°C	—
Thermocouple locations	Max. temperature rise measured, ΔT (K)	Max. temperature rise limit, ΔT (K)	
Inlet	16,5	45	
Ambient of mechanical switch	49,6	T85-25=60	
Ambient of thermal cut-out	39,4	T210-25=185	
Internal wire near heating element	29,0	T180-25=155	
Ambient of thermostat	27,0	T220-25=195	
Silicone tube	66,2	T200-25=175	
Ambient of micro switch	36,5	T85-25=60	
Control panel, inside / Lamp cover, inside	30,4	For Cl.30	
Lamp PCB	30,2	120	

IEC 60335-2-15			
Clause	Requirement + Test	Result - Remark	Verdict
	Knob of control panel	37,6	60
	Handle	22,2	60
	Lid of cover	51,8	60
	Knob of mechanical switch	26,4	60
	Test corner (floor)	15,5	65
Supplementary information:			

11.8n	TABLE: Heating test (Model SRC28S-WPY3)		P
	Test voltage (V)..... :	259,8 V	—
	Ambient (°C)..... :	t ₁ = 23,8°C, t ₂ = 22,1°C	—
Thermocouple locations	Max. temperature rise measured, ΔT (K)	Max. temperature rise limit, ΔT (K)	
Power cord	16,8	50	
Ambient of mechanical switch	49,7	T85-25=60	
Ambient of thermal cut-out	37,1	T210-25=185	
Internal wire near heating element	29,0	T180-25=155	
Ambient of thermostat	26,9	T220-25=195	
Silicone tube	66,2	T200-25=175	
Ambient of micro switch	36,5	T85-25=60	
Control panel, inside / Lamp cover, inside	30,5	For Cl.30	
Lamp PCB	30,2	120	
Knob of control panel	37,6	60	
Handle	22,3	60	
Lid of cover	52,1	60	
Knob of mechanical switch	26,4	60	
Test corner (floor)	15,6	65	
Supplementary information:			

IEC 60335-2-15			
Clause	Requirement + Test	Result - Remark	Verdict

11.8	TABLE: Heating test, resistance method			N/A		
	Test voltage (V).....:			—		
	Temperature rise of winding	R1 (Ω)	R2 (Ω)	ΔT (K)	Max. ΔT (K)	Insulation class
Supplementary information:						

13.2	TABLE: Leakage current			P
	Heating appliances: 1,15 x rated input (W).....:	Model RC03-Y: 275,5W Model RC06B-AY3: 438,3W Model RC28A-NX3: 1252,2W Model RC120A-AY2: 4382,6W Model DRC10S1-GWA3: 563,5W Model DRC36S-GPA3: 1627,8W Model SRC06S1-WPY3: 438,3 W Model SRC28S-WPY3: 1252,2W Model RC03-X: 275,5W Model RC06B-AX3: 438,3W Model RC28A-GY1: 1252,2W Model DRC36C-CWA3: 1627,8W Model SRC06S1-WPX3: 375,7W Model SRC28C-UWX3: 1252,2W		—
	Motor-operated and combined appliances: 1,06 x rated voltage (V).....:		--	—
	Leakage current between:	I (mA)	Max. allowed I (mA)	
	Between live part and plastic enclosure / button	0,06	0,35 (Peak)	
	Between live part and earthed metal	0,12	0,75	
Supplementary information:				

IEC 60335-2-15			
Clause	Requirement + Test	Result - Remark	Verdict

13.3	TABLE: Electric strength		P
Test voltage applied between:		Voltage (V)	Breakdown (Yes/No)
Between live part and plastic enclosure / button		3000	No
Between live part and earthed metal		1000	No
Supplementary information:			

14	TABLE: Transient overvoltages					N/A
Clearance between:	cl (mm)	Required cl (mm)	Rated impulse voltage (V)	Impulse test voltage (V)	Flashover (Yes/No)	
Supplementary information:						

16.2	TABLE: Leakage current		P
Single phase appliances: 1,06 x rated voltage (V)..... :		254,4 V	—
Three phase appliances 1,06 x rated voltage divided by $\sqrt{3}$ (V)..... :		--	—
Leakage current between:		I (mA)	Max. allowed I (mA)
Between live part and plastic enclosure / button		0,08	0,25
Between live part and earthed metal		0,12	0,75
Supplementary information:			

16.3	TABLE: Electric strength		P
Test voltage applied between:		Voltage (V)	Breakdown (Yes/No)
Between live part and plastic enclosure / button		3000	No
Between live part and earthed metal		1250	No
Supplementary information:			

17	TABLE: Overload protection, thermocouple measurements		N/A
Temperature rise of part/at:		ΔT (K)	Max. ΔT (K)
Supplementary information:			

IEC 60335-2-15					
Clause	Requirement + Test	Result - Remark			Verdict
17	TABLE: Overload protection, resistance method				N/A
	Test voltage (V).....:				—
	Ambient, t ₁ (°C).....:				—
	Ambient, t ₂ (°C).....:				—
Temperature of winding	R1 (Ω)	R2 (Ω)	ΔT (K)	T (°C)	Max. T (°C)
Supplementary information:					

19	Abnormal operation conditions						P
Operational characteristics		YES/NO	Operational conditions				
Are there electronic circuits to control the appliance operation?		No	--				
Are there “off” or “stand-by” position?		No	--				
The unintended operation of the appliance results in dangerous malfunction?		No	--				
Sub-clause	Operating conditions description	Test results description	PEC description	EMP 19.11.4	Software type required	19.11.3 PEC	Final result
19.2	0,85 times rated power operation, empty	No hazards	--	--	--	--	P
19.3	1,24 times rated power operation, empty	No hazards	--	--	--	--	P
19.4	1,15 times rated power operation	No hazards	--	--	--	--	P
19.5	--	--	--	--	--	--	N/A
19.6	--	--	--	--	--	--	N/A
19.7	--	--	--	--	--	--	N/A
19.8	--	--	--	--	--	--	N/A
19.9	--	--	--	--	--	--	N/A
19.10	--	--	--	--	--	--	N/A
19.11.2	--	--	--	--	--	--	N/A
19.11.4.8	--	--	--	--	--	--	N/A
19.10X	--	--	--	--	--	--	N/A
Supplementary information:							

IEC 60335-2-15						
Clause	Requirement + Test	Result - Remark			Verdict	
19.7	TABLE: Abnormal operation, locked rotor/moving parts				N/A	
	Test voltage (V).....:				—	
	Ambient, t ₁ (°C).....:				—	
	Ambient, t ₂ (°C).....:				—	
Temperature of winding		R1 (Ω)	R2 (Ω)	ΔT (K)	T (°C)	Max. T (°C)
Supplementary information:						

19.9	TABLE: Abnormal operation, running overload				N/A	
	Test voltage (V).....:				—	
	Ambient, t ₁ (°C).....:				—	
	Ambient, t ₂ (°C).....:				—	
Temperature of winding		R1 (Ω)	R2 (Ω)	ΔT (K)	T (°C)	Max. T (°C)
Supplementary information:						

IEC 60335-2-15				
Clause	Requirement + Test	Result - Remark		Verdict
19.13a	TABLE: Abnormal operation, temperature rises (Model RC03-Y)			P
Thermocouple locations	Max. temperature rise measured, ΔT (K)			Max. temperature rise limit, ΔT (K)
	19.2	19.3	19.4	
Power cord	28,6	33,6	94,9	150
Control panel inside / Lamp cover, inside	22,3	27,0	--	For Cl.30
Test corner (floor)	4,5	6,6	15,8	150
Supplementary information:				

19.13b	TABLE: Abnormal operation, temperature rises (Model RC06B-AY3)			P
Thermocouple locations	Max. temperature rise measured, ΔT (K)			Max. temperature rise limit, ΔT (K)
	19.2	19.3	19.4	
Power cord	36,7	34,4	42,4	150
Control panel inside / Lamp cover, inside	33,7	37,8	--	For Cl.30
Test corner (floor)	26,5	2,0	24,7	150
Supplementary information:				

19.13b	TABLE: Abnormal operation, temperature rises (Model RC28A-GY1)			P
Thermocouple locations	Max. temperature rise measured, ΔT (K)			Max. temperature rise limit, ΔT (K)
	19.2	19.3	19.4	
Power cord	30,3	42,3	101,2	150
Control panel inside / Lamp cover, inside	19,6	26,6	--	For Cl.30
Test corner (floor)	6,7	8,2	16,8	150
Supplementary information:				

19.13c	TABLE: Abnormal operation, temperature rises (Model RC120A-AY2)			P
Thermocouple locations	Max. temperature rise measured, ΔT (K)			Max. temperature rise limit, ΔT (K)
	19.2	19.3	19.4	
Power cord	57,0	78,7	142,4	150
Control panel inside / Lamp cover, inside	47,8	59,2	--	For Cl.30
Test corner (floor)	2,2	3,3	10,6	150
Supplementary information:				

IEC 60335-2-15			
Clause	Requirement + Test	Result - Remark	Verdict

19.13d	TABLE: Abnormal operation, temperature rises (Model DRC10S1-GWA3)			P
Thermocouple locations	Max. temperature rise measured, ΔT (K)			Max. temperature rise limit, ΔT (K)
	19.2	19.3	19.4	
Control panel inside / Lamp cover, inside	33,7	41,9	--	For Cl.30
Bottom plastic enclosure	36,9	45,3	--	For Cl.30
Test corner (floor)	22,1	30,0	61,9	150
Supplementary information:				

19.13e	TABLE: Abnormal operation, temperature rises (Model DRC36S-GPA3)			P
Thermocouple locations	Max. temperature rise measured, ΔT (K)			Max. temperature rise limit, ΔT (K)
	19.2	19.3	19.4	
Control panel inside / Lamp cover, inside	28,2	33,6	--	For Cl.30
Bottom plastic enclosure	30,1	39,5	--	For Cl.30
Test corner (floor)	21,1	27,5	69,7	150
Supplementary information:				

19.13f	TABLE: Abnormal operation, temperature rises (Model SRC06S1-WPY3)			P
Thermocouple locations	Max. temperature rise measured, ΔT (K)			Max. temperature rise limit, ΔT (K)
	19.2	19.3	19.4	
Power cord	45,5	54,0	33,0	150
Control panel inside / Lamp cover, inside	35,3	41,8	--	For Cl.30
Test corner (floor)	10,1	13,1	23,0	150
Supplementary information:				

19.13g	TABLE: Abnormal operation, temperature rises (Model SRC28S-WPY3)			P
Thermocouple locations	Max. temperature rise measured, ΔT (K)			Max. temperature rise limit, ΔT (K)
	19.2	19.3	19.4	
Power cord	59,1	66,3	28,8	150
Control panel inside / Lamp cover, inside	39,9	46,2	--	For Cl.30
Test corner (floor)	13,9	13,4	33,0	150
Supplementary information:				

IEC 60335-2-15			
Clause	Requirement + Test	Result - Remark	Verdict

21.1	TABLE: Impact resistance			P
Impacts per surface	Surface tested	Impact energy (Nm)	Comments	
3	Enclosure	0,5	P	
3	Control panel	0,5	P	
Supplementary information:				

24.1	TABLE: Components information					P
Object/part No.	Manufacturer/ trademark	Type/model	Technical data	Standard	Mark(s) of conformity ¹⁾	
Plug for Germany	Guangdong Yincheng Electric Appliance Co. Ltd.	YC-F16	AC250V, 16A	DIN VDE 0620-1 (VDE 0620-1):2010-02	VDE 40026066	
Alternative	Zhanjiang Anjia Electronics Industry Co., Ltd.	AJ-05	AC250V, 16A	DIN VDE 0620-1 (VDE 0620-1):2010-02	VDE 40022027	
Alternative	Zhanjiang Yexing Electrical Appliance Co., Ltd	YX301	AC250V, 16A	DIN VDE 0620-1 (VDE 0620-1):2010-02	VDE 40027107	
Alternative	Lian Dung Electric Wire Material Co., Ltd.	LT-322	AC250V, 16A	DIN VDE 0620-1 (VDE 0620-1):2010-02	VDE 40014921	
Alternative	Guangdong Xiongrun Electrical Co., Ltd	XR-324	AC250V, 16A	DIN VDE 0620-1 (VDE 0620-1):2010-02	VDE 40042709	
Alternative	Yuyao Zhongjian Electric Appliance Co., Ltd.	ZJ-03	AC250V, 16A	DIN VDE 0620-1 (VDE 0620-1):2010-02	VDE 40046201	
Plug for South Africa	Longwell Company	LP-39	AC250V, 16A	SANS 164-1: 2007	SABS 7381/10945	
Alternative	I-Sheng Electrical Wire & Cable Co., Ltd	SP-80A, SP-80B	AC250V, 16A	SANS 164-1: 2007	SABS 7276/14037	
Plug for South Africa (for models not more than 1300W)	Longwell Company	LP-38, LP-39	AC 250 V, 6A	SANS 164-1: 2007	SABS 7381/10945	
Alternative	I-Sheng Electrical Wire & Cable Co., Ltd	SP-81A, SP-81B	AC 250 V, 6A	SANS 164-1: 2007	SABS 7276/14037	
Plug for South Africa (for models not more than 2200W)	I-Sheng Electrical Wire & Cable Co., Ltd	SP-81A, SP-81B	AC 250V, 10A	SANS 164-1: 2007	SABS 7276/14037	
Alternative	Longwell Company	LP-39	AC 250V, 10A	SANS 164-1: 2007	SABS 7381/10945	

IEC 60335-2-15					
Clause	Requirement + Test			Result - Remark	Verdict
Plug for AU (for models not more than 2200W)	Yuyao Zhongjian Electric Appliance Co., Ltd.	ZJ-16	AC 250V, 10A	AS/NZS 3112: 2000	SAA-161733-EA
Alternative	Guangdong XiongRun Electrical Co Ltd	XR-351A, PL3	AC 250V, 10A	AS/NZS 3112: 2000	ESO120717/00
Alternative	Zhanjiang Anjia Electronics Industry Co Ltd	AJ-07	AC 250V, 10A	AS/NZS 3112: 2000	NSW 23515
Alternative	Lian Dung Electric Wire Material Company Ltd	LT-423	AC 250V, 10A	AS/NZS 3112: 2000	NSW 25509
Alternative	Shangyu Jintao Electron Co Ltd	A3-10, A3-10B	AC 250V, 10A	AS/NZS 3112: 2000	ESO120467/00
Alternative	Shenzhen Ye Tatsu Electrocal Co., Ltd	YTS08	AC 250V, 10A	AS/NZS 3112: 2000	NSW26266
Plug for AU (for models not more than 3200W)	Shangyu Jintao Electron Co., Ltd.	A3-15	AC 250V, 15A	AS/NZS 3112: 2000	ESO120467/00
Alternative	Guangdong XiongRun Electrical Co Ltd	XR-352	AC 250V, 15A	AS/NZS 3112: 2000	ESO120718/00
Plug for UK (for models not more than 2800W)	Luen Tai Ip's Electrical (Shenzhen) Co., Ltd.	9518	AC 250V, 13A	BS 1363-1:1995+A4:2012	BSI KM40790
Alternative	Scolmore International	SW168	AC 250V, 13A	BS 1363-1:1995+A4:2012	KM10807
Alternative	Kenic Electric Mfg Co., Ltd	KE-88	AC 250V, 13A	BS 1363-1:1995+A4:2012	BSI KM54019
Alternative	DongGuang YingTai Electric Co., LTD	CWL 668	AC 250V, 13A	BS 1363-1:1995+A4:2012	BSI KM82901
Alternative	Yuyao Zhongjian Electric Appliance Co., Ltd.	ZJ-007, ZJ-008	AC 250V, 13A	BS 1363-1:1995+A4:2012	ASTA 1282
Alternative	Dongguan Lian Dung Electric Co., Ltd.	LT-318, LT-328	AC 250V, 13A	BS 1363-1:1995+A4:2012	BSI KM68559
Alternative	Guangdong XiongRun Electrical Company Limited	XR-318, XR-318A	AC 250V, 13A	BS 1363-1:1995+A4:2012	ASTA 737
Plug for Italy (for models not more than 2200W)	Kenic Electric Mfg Co., Ltd	KE-29	AC 250V, 10A	CEI 23-50 - II Ed. 2007 + V1:2008 + V2:2011	IMQ EM352
Alternative	LIAN DUNG ELECTRIC WIRE MAT. CO., LTD	LT-319	AC 250V, 10A	CEI 23-50 - II Ed. 2007 + V1:2008 + V2:2011	IMQ EI849

IEC 60335-2-15					
Clause	Requirement + Test			Result - Remark	Verdict
Alternative	NINGBO QIAOPU ELECTRIC CO., LTD.	D08	AC 250V, 10A	CEI 23-50 - II Ed. 2007 + V1:2008 + V2:2011	IMQ CA02.01117
Plug for SEV for models rated Power not more than 2200W	Kenic Electric Mfg Co. Ltd.	KE-28	AC 250V, 10A	SEV1011: 2009 IEC 60884-1: 2002+A1:06	S+ 08.0865
Alternative	Lian Dung Electric Wire Material Co., Ltd.	LT-313	AC 250V, 10A	SEV1011: 2009 IEC 60884-1: 2002+A1:06	S+ 17.0598
Alternative	Guangdong Xiongrun Electrical Co., Ltd	XR-313	AC 250V, 10A	SEV1011: 2009 IEC 60884-1: 2002+A1:06	S+ 17.0215
Alternative	Ningbo Qiaopu Electric Co., Ltd.	D13	AC 250V, 10A	SEV1011: 2009 IEC 60884-1: 2002+A1:06	S+ 17.0974
Plug for Singapore (for models not more than 2800W)	Guangdong Xiongrun Electrical Co., Ltd	XR-318A	AC 250V, 13A	SS145: PART 1: 2010	140903-12
Alternative	Yuyao Zhongjian Electric Appliance Co., Ltd.	ZJ-006	AC 250V, 13A	SS145: PART 1: 2010	161533-12
Alternative	Global Approvals Pte Ltd.	9518	AC 250V, 13A	SS145: PART 1: 2010	141881-12
Plug for Korea	Ningbo Qiaopu Electric Co., Ltd.	K03	AC 250 V, 16 A	K60884-1(200812) KSC8305(2008-09)	KC SU04048-5002C
Alternative	Guangdong Yincheng Electric Appliance Co., Ltd.	YCH-16	AC 250 V, 16 A	K60884-1(200812) KSC8305(2008-09)	KC SU04172-14002
Alternative	Guangdong Xiongrun Electrical Co., Ltd	XR-328	AC 250 V, 16 A	K60884-1(200812) KSC8305(2008-09)	KC HU04070-10002A
Alternative	Hangzhou Leadership Electric Component Co., Ltd.	LT-418	AC 250 V, 16 A	K60884-1(200812) KSC8305(2008-09)	KC SU04036-4002E
Plug for SASO for models rated Power not more than 2800W	Yuyao Zhongjian Electric Appliance Co., Ltd.	ZJ-006	AC 250 V, 13 A	SASO 2203: 2015	GCC D012-1847
Alternative	Shengzhen zhuo xing Electric Appliance Co., Ltd	9518	AC 250 V, 13 A	SASO 2203: 2015	GCC D012-2689

IEC 60335-2-15					
Clause	Requirement + Test		Result - Remark		Verdict
Plug for Indonesia	Guangdong Yincheng Electric Appliance Co., Ltd.	YCN-16	AC 250V, 16A	SNI 04-3892.1:2006 SNI 04-3892.1.1:2003	SNI 04-3892
Alternative	Guangdong Xiongrun Electrical Co., Ltd	XR-211	AC 250V, 16A	SNI 04-3892.1:2006 SNI 04-3892.1.1:2003	SNI 04-3892.1
Alternative	Guangdong Xiongrun Electrical Co., Ltd	XR-322	AC 250V, 16A	SNI 04-3892.1:2006 SNI 04-3892.1.1:2003	SNI 04-3892.1
Alternative	Guangdong Xiongrun Electrical Co., Ltd	XR-323	AC 250V, 16A	SNI 04-3892.1:2006 SNI 04-3892.1.1:2003	SNI 04-3892.1
Plug for Thailand	Lian Dung Electric Wire Material Co., Ltd.	LT-420A	AC 250V, 16A	TIS.166-2549	TISI E0279(E)/54
Alternative	Lian Dung Electric Wire Material Co., Ltd.	LT-420	AC 250V, 16A	TIS.166-2549	TISI E0278(E)/54
Plug for China	Guangdong Yincheng Electric Appliance Co., Ltd.	YC-16	AC 250V, 16A	GB2099.1-2008 GB1002-2008	CCC 20020102010 18951
Alternative	Maoming Maogang Jiada Electrical Appliance factory	JD3-16	AC 250V, 16A	GB2099.1-2008 GB1002-2008	CCC 20140102017 11945
Alternative	Lianjiang Yinsheng Electric Factory	YS-16	AC 250V, 16A	GB2099.1-2008 GB1002-2008	CCC 20150102017 97337
Alternative	Guangdong Zhongxing Electric Co., Ltd.	ZX-16	AC 250V, 16A	GB2099.1-2008 GB1002-2008	CCC 20110102014 99353
Plug for China (for models not more than 2200W)	Guangdong Yincheng Electric Appliance Co., Ltd.	YC-10	AC250V, 10A	GB2099.1-2008 GB1002-2008	CCC 20020102010 18951
Alternative	Maoming Maogang Jiadaelecirical Appliance factory	JD3-10	AC250V, 10A	GB2099.1-2008 GB1002-2008	CCC 20140102017 11945
Alternative	Lianjiang Yinsheng Electric Factory	YS-10	AC250V, 10A	GB2099.1-2008 GB1002-2008	CCC 20150102017 97337
Alternative	Guangdong Zhongxing Electric Co., Ltd.	ZX-10	AC250V, 10A	GB2099.1-2008 GB1002-2008	CCC 20110102014 99353
Power cord (for models not more than 550W)	Guangdong Yincheng Electric Appliance Co. Ltd.	H03VV-F	3G0,5mm ² (Length < 2m)	EN50525-2-11: 2011 EC 60227-5 :2011	VDE 40018525

IEC 60335-2-15					
Clause	Requirement + Test			Result - Remark	Verdict
Alternative	Zhanjiang Anjia Electronics Industry Co., Ltd.	H03VV-F	3G0,5mm ² (Length < 2m)	EN50525-2-11: 2011 EC 60227-5 :2011	VDE 40017611
Alternative	Zhanjiang Yexing Electrical Appliance Co., Ltd	H03VV-F	3G0,5mm ² (Length < 2m)	EN50525-2-11: 2011 EC 60227-5 :2011	VDE 40021360
Alternative	Kenic Electric Mfg Co., Ltd	H03VV-F	3G0,5mm ² (Length < 2m)	EN50525-2-11: 2011 EC 60227-5 :2011	VDE 103853
Alternative	I-Sheng Electric Wire & Cable Co., Ltd	H03VV-F	3G0,5mm ² (Length < 2m)	EN50525-2-11: 2011 EC 60227-5 :2011	VDE 40006070
Alternative	Lian Dung Electric Wire Material Co., Ltd.	H03VV-F	3G0,5mm ² (Length < 2m)	EN50525-2-11: 2011 EC 60227-5 :2011	VDE 127334
Alternative	Guangdong Xiongrun Electrical Co., Ltd	H03VV-F	3G0,5mm ² (Length < 2m)	EN50525-2-11: 2011 EC 60227-5 :2011	VDE 40020627
Alternative	Yuyao Zhongjian Electric Appliance Co., Ltd.	H03VV-F	3G0,5mm ² (Length < 2m)	EN50525-2-11: 2011 EC 60227-5 :2011	VDE 40033849
Alternative	Ningbo Qiaopu Electric Co., Ltd.	H03VV-F	3G0,5mm ² (Length < 2m)	EN50525-2-11: 2011 EC 60227-5 :2011	VDE 40035976
Alternative	Guangdong Yincheng Electric Appliance Co. Ltd.	H05VV-F	3G0,75mm ² (Length < 2m)	EN50525-2-11: 2011 EC 60227-5 :2011	VDE 40018525
Alternative	Zhanjiang Anjia Electronics Industry Co., Ltd.	H05VV-F	3G0,75mm ² (Length < 2m)	EN50525-2-11: 2011 EC 60227-5 :2011	VDE 40017611
Alternative	Zhanjiang Yexing Electrical Appliance Co., Ltd	H05VV-F	3G0,75mm ² (Length < 2m)	EN50525-2-11: 2011 EC 60227-5 :2011	VDE 40021360
Alternative	Kenic Electric Mfg Co., Ltd	H05VV-F	3G0,75mm ² (Length < 2m)	EN50525-2-11: 2011 EC 60227-5 :2011	VDE 103853
Alternative	I-Sheng Electric Wire & Cable Co., Ltd	H05VV-F	3G0,75mm ² (Length < 2m)	EN50525-2-11: 2011 EC 60227-5 :2011	VDE 40006070
Alternative	Lian Dung Electric Wire Material Co., Ltd.	H05VV-F	3G0,75mm ² (Length < 2m)	EN50525-2-11: 2011 EC 60227-5 :2011	VDE 127334
Alternative	Guangdong Xiongrun Electrical Co., Ltd	H05VV-F	3G0,75mm ² (Length < 2m)	EN50525-2-11: 2011 EC 60227-5 :2011	VDE 40020627
Alternative	Yuyao Zhongjian Electric Appliance Co., Ltd.	H05VV-F	3G0,75mm ² (Length < 2m)	EN50525-2-11: 2011 EC 60227-5 :2011	VDE 40033849
Alternative	Ningbo Qiaopu Electric Co., Ltd.	H05VV-F	3G0,75mm ² (Length < 2m)	EN50525-2-11: 2011 EC 60227-5 :2011	VDE 40035976
Alternative	Guangdong Yincheng Electric Appliance Co., Ltd.	H03VV-F	3G0,5mm ² (Length < 2m)	EN50525-2-11: 2011 EC 60227-5 :2011	CB CN29241

IEC 60335-2-15					
Clause	Requirement + Test			Result - Remark	Verdict
Alternative	Guangdong Yincheng Electric Appliance Co., Ltd.	H05VV-F	3G0,75mm ² (Length < 2m)	EN50525-2-11: 2011 EC 60227-5 :2011	CB CN29321
Power cord for AU(for models not more than 550W)	Guangdong Xiongrun Electrical Co Ltd	H03VV-F	3G0,5mm ² (Length < 2m)	AS/NZS3191:2003	SAA ESO130530/00
Alternative	Guangdong Xiongrun Electrical Co Ltd	H05VV-F	3G0,75mm ² (Length < 2m)	AS/NZS3191:2003	SAA ESO130530/00
Alternative	Zhanjiang Anjia Electronics Industry Co., Ltd.	H05VV-F	3G0,75mm ² (Length < 2m)	AS/NZS3191:2003	NSW 22933
Alternative	Shenzhen Ye Tatsu Electrocal Co., Ltd	H05VV-F	3G0,75mm ² (Length < 2m)	AS/NZS3191:2003	NSW 26183
Power cord for Indonesia (for models not more than 550W)	Guangdong Xiongrun Electrical Co. Ltd	H03VV-F	3G0,5mm ² (Length < 2m)	SNI 04-6629.1: 2006 SNI 04-6629.2: 2006 SNI 04-6629.5: 2006	SNI 04-6629.5
Alternative	Guangdong Yincheng Electric Appliance Co., Ltd.	H03VV-F	3G0,5mm ² (Length < 2m)	SNI 04-6629.1: 2006 SNI 04-6629.2: 2006 SNI 04-6629.5: 2006	SNI 04-2892.1
Alternative	Guangdong Xiongrun Electrical Co. Ltd	H05VV-F	3G0,75mm ² (Length < 2m)	SNI 04-6629.1: 2006 SNI 04-6629.2: 2006 SNI 04-6629.5: 2006	SNI 04-6629.5
Alternative	Guangdong Yincheng Electric Appliance Co., Ltd.	H05VV-F	3G0,75mm ² (Length < 2m)	SNI 04-6629.1: 2006 SNI 04-6629.2: 2006 SNI 04-6629.5: 2006	SNI 04-2892.1
Power cord (for models not more than 550W, not for CE, GS)	Guangdong Yincheng Electric Appliance Co., Ltd.	60227 IEC 52(RVV) 300/300V	3G0,5mm ² (Length < 2m)	GB/T 5023.5-2008 IEC 60227-5:2003	CCC 20020101050 13874
Alternative	Maoming Maogang Jiada Electrical Appliance Factory	60227 IEC 52(RVV) 300/300V	3G0,5mm ² (Length < 2m)	GB/T 5023.5-2008 IEC 60227-5:2003	CCC 20140101057 12143
Alternative	Lianjiang Yinsheng Electric Factory	60227 IEC 52(RVV) 300/300V	3G0,5mm ² (Length < 2m)	GB/T 5023.5-2008 IEC 60227-5:2003	CCC 20150101058 05461
Alternative	Guangdong Zhongxing Electric Co., Ltd.	60227 IEC 52(RVV) 300/300V	3G0,5mm ² (Length < 2m)	GB/T 5023.5-2008 IEC 60227-5:2003	CCC 20110101055 07200

IEC 60335-2-15					
Clause	Requirement + Test			Result - Remark	Verdict
Alternative	Guangdong Yincheng Electric Appliance Co., Ltd.	60227 IEC 52(RVV) 300/500V	3G0,75mm ² (Length < 2m)	GB/T 5023.5-2008 IEC 60227-5:2003	CCC 20020101050 13874
Alternative	Maoming Maogang Jiada Electrical Appliance Factory	60227 IEC 52(RVV) 300/500V	3G0,75mm ² (Length < 2m)	GB/T 5023.5-2008 IEC 60227-5:2003	CCC 20140101057 12143
Alternative	Lianjiang Yinsheng Electric Factory	60227 IEC 52(RVV) 300/500V	3G0,75mm ² (Length < 2m)	GB/T 5023.5-2008 IEC 60227-5:2003	CCC 20150101058 05461
Alternative	Guangdong Zhongxing Electric Co., Ltd.	60227 IEC 52(RVV) 300/500V	3G0,75mm ² (Length < 2m)	GB/T 5023.5-2008 IEC 60227-5:2003	CCC 20110101055 07200
Power cord (for models not more than 2200W)	Guangdong Yincheng Electric Appliance Co., Ltd.	H05VV-F	3G0,75mm ² (Length < 2m)	EN50525-2-11:2011 IEC 60227-5:2011	VDE 40018525
Alternative	Zhanjiang Anjia Electronics Industry Co., Ltd.	H05VV-F	3G0,75mm ² (Length < 2m)	EN50525-2-11:2011 IEC 60227-5:2011	VDE 40017611
Alternative	Zhanjiang Yexing Electrical Appliance Co., Ltd	H05VV-F	3G0,75mm ² (Length < 2m)	EN50525-2-11:2011 IEC 60227-5:2011	VDE 40021360
Alternative	Kenic Electric Mfg Co., Ltd	H05VV-F	3G0,75mm ² (Length < 2m)	EN50525-2-11:2011 IEC 60227-5:2011	VDE 103853
Alternative	I-Sheng Electric Wire & Cable Co., Ltd	H05VV-F	3G0,75mm ² (Length < 2m)	EN50525-2-11:2011 IEC 60227-5:2011	VDE 40006070
Alternative	Lian Dung Electric Wire Material Co., Ltd.	H05VV-F	3G0,75mm ² (Length < 2m)	EN50525-2-11:2011 IEC 60227-5:2011	VDE 127334
Alternative	Guangdong Xiongrun Electrical Co., Ltd	H05VV-F	3G0,75mm ² (Length < 2m)	EN50525-2-11:2011 IEC 60227-5:2011	VDE 40020627
Alternative	Yuyao Zhongjian Electric Appliance Co., Ltd.	H05VV-F	3G0,75mm ² (Length < 2m)	EN50525-2-11:2011 IEC 60227-5:2011	VDE 40033849
Alternative	Ningbo Qiaopu Electric Co., Ltd.	H05VV-F	3G0,75mm ² (Length < 2m)	EN50525-2-11:2011 IEC 60227-5:2011	VDE 40035976
Alternative	Guangdong Yincheng Electric Appliance Co., Ltd.	H05VV-F	3G1,0mm ² (Length < 2m)	EN50525-2-11:2011 IEC 60227-5:2011	VDE 40018525
Alternative	Zhanjiang Anjia Electronics Industry Co., Ltd.	H05VV-F	3G1,0mm ² (Length < 2m)	EN50525-2-11:2011 IEC 60227-5:2011	VDE 40017611
Alternative	Zhanjiang Yexing Electrical Appliance Co., Ltd	H05VV-F	3G1,0mm ² (Length < 2m)	EN50525-2-11:2011 IEC 60227-5:2011	VDE 40021360

IEC 60335-2-15					
Clause	Requirement + Test			Result - Remark	Verdict
Alternative	Kenic Electric Mfg Co., Ltd	H05VV-F	3G1,0mm ² (Length < 2m)	EN50525-2-11:2011 IEC 60227-5:2011	VDE 103853
Alternative	I-Sheng Electric Wire & Cable Co., Ltd	H05VV-F	3G1,0mm ² (Length < 2m)	EN50525-2-11:2011 IEC 60227-5:2011	VDE 40006070
Alternative	Lian Dung Electric Wire Material Co., Ltd.	H05VV-F	3G1,0mm ² (Length < 2m)	EN50525-2-11:2011 IEC 60227-5:2011	VDE 127334
Alternative	Guangdong Xiongrun Electrical Co., Ltd	H05VV-F	3G1,0mm ² (Length < 2m)	EN50525-2-11:2011 IEC 60227-5:2011	VDE 40020627
Alternative	Yuyao Zhongjian Electric Appliance Co., Ltd.	H05VV-F	3G1,0mm ² (Length < 2m)	EN50525-2-11:2011 IEC 60227-5:2011	VDE 40033849
Alternative	Ningbo Qiaopu Electric Co., Ltd.	H05VV-F	3G1,0mm ² (Length < 2m)	EN50525-2-11:2011 IEC 60227-5:2011	VDE 40035976
Alternative	Guangdong Yincheng Electric Appliance Co., Ltd.	H05VV-F	3G0,75mm ² (Length < 2m)	EN50525-2-11:2011 IEC 60227-5:2011	CB CN29321
Alternative	Guangdong Yincheng Electric Appliance Co., Ltd.	H05VV-F	3G1,0mm ² (Length < 2m)	EN50525-2-11:2011 IEC 60227-5:2011	CB CN29321
Power cord for Korea (for models not more than 2200W)	I-Sheng Manufactur (songgang) Factory	H05VV-F 60227 IEC 53	3G0,75mm ² (Length < 2m)	K60227-5(2011-12)	KC SU01015-4001
Alternative	Ningbo Qiaopu Electric Co., Ltd.	H05VV-F 60227 IEC 53	3G0,75mm ² (Length < 2m)	K60227-5(2011-12)	KC SU01035-5002B
Alternative	Guangdong Xiongrun Electrical Co., Ltd	H05VV-F 60227 IEC 53	3G0,75mm ² (Length < 2m)	K60227-5(2011-12)	KC HU01034-10003A
Alternative	Guangdong Yincheng Electric Appliance Co., Ltd.	H05VV-F 60227 IEC 53	3G0,75mm ² (Length < 2m)	K60227-5(2011-12)	KC SU01113-14001
Alternative	I-Sheng Manufacture (songgang) Factory	H05VV-F 60227 IEC 53	3G1,0mm ² (Length < 2m)	K60227-5(2011-12)	KC SU01015-4001
Alternative	Ningbo Qiaopu Electric Co., Ltd.	H05VV-F 60227 IEC 53	3G1,0mm ² (Length < 2m)	K60227-5(2011-12)	KC SU01035-5002B
Alternative	Guangdong Xiongrun Electrical Co., Ltd	H05VV-F 60227 IEC 53	3G1,0mm ² (Length < 2m)	K60227-5(2011-12)	KC HU01034-10003A
Alternative	Guangdong Yincheng Electric Appliance Co., Ltd.	H05VV-F 60227 IEC 53	3G1,0mm ² (Length < 2m)	K60227-5(2011-12)	KC SU01113-14001

IEC 60335-2-15					
Clause	Requirement + Test			Result - Remark	Verdict
Power cord for AU (for models not more than 2200W)	Shenzhen Tongyuan Industrial Co., Ltd	H05VV-F	3G0,75mm ² (Length < 2m)	AS/NZS3191:2003	NSW 24638
Alternative	Shangyu Jintao Electron Co., Ltd.	H05VV-F	3G0,75mm ² (Length < 2m)	AS/NZS3191:2003	SAA ESO120467/00
Alternative	Guangdong Xiongrun Electrical Co., Ltd	H05VV-F	3G0,75mm ² (Length < 2m)	AS/NZS3191:2003	SAA ESO130530/00
Alternative	Yuyao Zhongjian Electric Appliance Co., Ltd.	H05VV-F	3G0,75mm ² (Length < 2m)	AS/NZS3191:2003	SAA-161393-EA
Alternative	Shenzhen Tongyuan Industrial Co., Ltd	H05VV-F	3G1,0mm ² (Length < 2m)	AS/NZS3191:2003	NSW 24638
Alternative	Shangyu Jintao Electron Co., Ltd.	H05VV-F	3G1,0mm ² (Length < 2m)	AS/NZS3191:2003	SAA ESO120467/00
Alternative	Guangdong Xiongrun Electrical Co., Ltd	H05VV-F	3G1,0mm ² (Length < 2m)	AS/NZS3191:2003	SAA ESO130530/00
Alternative	Yuyao Zhongjian Electric Appliance Co., Ltd.	H05VV-F	3G1,0mm ² (Length < 2m)	AS/NZS3191:2003	SAA-161393-EA
Power cord for Indonesia (for models not more than 2200W)	Guangdong Xiongrun Electrical Co., Ltd	H05VV-F	3G0,75mm ² (Length < 2m)	SNI 04-6629.1: 2006 SNI 04-6629.2: 2006 SNI 04-6629.5: 2006	079 127-12
Alternative	Guangdong Yincheng Electric Appliance Co., Ltd.	H05VV-F	3G0,75mm ² (Length < 2m)	SNI 04-6629.1: 2006 SNI 04-6629.2: 2006 SNI 04-6629.5: 2006	SNI 04-3892.1
Alternative	Guangdong Xiongrun Electrical Co. Ltd	H05VV-F	3G0,75mm ² (Length < 2m)	SNI 04-6629.1: 2006 SNI 04-6629.2: 2006 SNI 04-6629.5: 2006	SNI 04-6629.5
Alternative	Guangdong Yincheng Electric Appliance Co., Ltd.	H05VV-F	3G1,0mm ² (Length < 2m)	SNI 04-6629.1: 2006 SNI 04-6629.2: 2006 SNI 04-6629.5: 2006	SNI
Alternative	Guangdong Xiongrun Electrical Co. Ltd	H05VV-F	3G1,0mm ² (Length < 2m)	SNI 04-6629.1: 2006 SNI 04-6629.2: 2006 SNI 04-6629.5: 2006	SNI 04-6629.5
Power cord (for models not more than 2200W, not for GS, CE)	Guangdong Yincheng Electric Appliance Co., Ltd.	60227 IEC 53(RVV) 300/500V	3G0,75mm ² (Length < 2m)	GB/T 5023.5-2008 IEC 60227-5:2003	CCC 2002010105013874
Alternative	Lianjiang Yinsheng Electric Factory	60227 IEC 53(RVV) 300/500V	3G0,75mm ² (Length < 2m)	GB/T 5023.5-2008 IEC 60227-5:2003	CCC 2015010105805461

IEC 60335-2-15					
Clause	Requirement + Test			Result - Remark	Verdict
Alternative	Guangdong Zhongxing Electric Co., Ltd.	60227 IEC 53(RVV) 300/500V	3G0,75mm ² (Length < 2m)	GB/T 5023.5-2008 IEC 60227-5:2003	CCC 20110101055 07200
Alternative	Maoming Maogang Jiada Electrical Appliance Factory	60227 IEC 53(RVV) 300/500V (Min)	3G0,75mm ² (Length < 2m)	GB/T 5023.5-2008 IEC 60227-5:2003	CCC 20140101057 12143
Alternative	Guangdong Yincheng Electric Appliance Co., Ltd.	60227 IEC 53(RVV) 300/500V	3G1,0mm ² (Length < 2m)	GB/T 5023.5-2008 IEC 60227-5:2003	CCC 20020101050 13874
Alternative	Lianjiang Yinsheng Electric Factory	60227 IEC 53(RVV) 300/500V	3G1,0mm ² (Length < 2m)	GB/T 5023.5-2008 IEC 60227-5:2003	CCC 20150101058 05461
Alternative	Guangdong Zhongxing Electric Co., Ltd.	60227 IEC 53(RVV) 300/500V	3G1,0mm ² (Length < 2m)	GB/T 5023.5-2008 IEC 60227-5:2003	CCC 20110101055 07200
Alternative	Maoming Maogang Jiada Electrical Appliance Factory	60227 IEC 53(RVV) 300/500V (Min)	3G1,0mm ² (Length < 2m)	GB/T 5023.5-2008 IEC 60227-5:2003	CCC 20140101057 12143
Power cord (for models not more than 3500W)	Guangdong Yincheng Electric Appliance Co., Ltd.	H05VV-F	3G1,0mm ² (Length < 2m)	EN50525-2-11:2011 IEC 60227-5:2011	VDE 40018525
Alternative	Zhanjiang Anjia Electronics Industry Co., Ltd.	H05VV-F	3G1,0mm ² (Length < 2m)	EN50525-2-11:2011 IEC 60227-5:2011	VDE 40017611
Alternative	Zhanjiang Yexing Electrical Appliance Co., Ltd	H05VV-F	3G1,0mm ² (Length < 2m)	EN50525-2-11:2011 IEC 60227-5:2011	VDE 40021360
Alternative	Kenic Electric Mfg Co., Ltd	H05VV-F	3G1,0mm ² (Length < 2m)	EN50525-2-11:2011 IEC 60227-5:2011	VDE 103853
Alternative	I-Sheng Electric Wire & Cable Co., Ltd	H05VV-F	3G1,0mm ² (Length < 2m)	EN50525-2-11:2011 IEC 60227-5:2011	VDE 40006070
Alternative	Lian Dung Electric Wire Material Co., Ltd.	H05VV-F	3G1,0mm ² (Length < 2m)	EN50525-2-11:2011 IEC 60227-5:2011	VDE 127334
Alternative	Guangdong Xiongrun Electrical Co., Ltd	H05VV-F	3G1,0mm ² (Length < 2m)	EN50525-2-11:2011 IEC 60227-5:2011	VDE 40020627
Alternative	Yuyao Zhongjian Electric Appliance Co., Ltd.	H05VV-F	3G1,0mm ² (Length < 2m)	EN50525-2-11:2011 IEC 60227-5:2011	VDE 40033849
Alternative	Ningbo Qiaopu Electric Co., Ltd.	H05VV-F	3G1,0mm ² (Length < 2m)	EN50525-2-11:2011 IEC 60227-5:2011	VDE 40035976
Alternative	Guangdong Yincheng Electric Appliance Co., Ltd.	H05VV-F	3G1,5mm ² (Length < 2m)	EN50525-2-11:2011 IEC 60227-5:2011	VDE 40018525

IEC 60335-2-15					
Clause	Requirement + Test			Result - Remark	Verdict
Alternative	Zhanjiang Anjia Electronics Industry Co., Ltd.	H05VV-F	3G1,5mm ² (Length < 2m)	EN50525-2-11:2011 IEC 60227-5:2011	VDE 40017611
Alternative	Zhanjiang Yexing Electrical Appliance Co., Ltd	H05VV-F	3G1,5mm ² (Length < 2m)	EN50525-2-11:2011 IEC 60227-5:2011	VDE 40021360
Alternative	Kenic Electric Mfg Co., Ltd	H05VV-F	3G1,5mm ² (Length < 2m)	EN50525-2-11:2011 IEC 60227-5:2011	VDE 103853
Alternative	I-Sheng Electric Wire & Cable Co., Ltd	H05VV-F	3G1,5mm ² (Length < 2m)	EN50525-2-11:2011 IEC 60227-5:2011	VDE 40006070
Alternative	Lian Dung Electric Wire Material Co., Ltd.	H05VV-F	3G1,5mm ² (Length < 2m)	EN50525-2-11:2011 IEC 60227-5:2011	VDE 127334
Alternative	Guangdong Xiongrun Electrical Co., Ltd	H05VV-F	3G1,5mm ² (Length < 2m)	EN50525-2-11:2011 IEC 60227-5:2011	VDE 40020627
Alternative	Yuyao Zhongjian Electric Appliance Co., Ltd.	H05VV-F	3G1,5mm ² (Length < 2m)	EN50525-2-11:2011 IEC 60227-5:2011	VDE 40033849
Alternative	Ningbo Qiaopu Electric Co., Ltd.	H05VV-F	3G1,5mm ² (Length < 2m)	EN50525-2-11:2011 IEC 60227-5:2011	VDE 40035976
Alternative	Guangdong Yincheng Electric Appliance Co., Ltd.	H05VV-F	3G1,0mm ² (Length < 2m)	EN50525-2-11:2011 IEC 60227-5:2011	CB CN29321
Alternative	Guangdong Yincheng Electric Appliance Co., Ltd.	H05VV-F	3G1,5mm ² (Length < 2m)	EN50525-2-11:2011 IEC 60227-5:2011	CB CN29321
Power cord for Korea (for models not more than 3500W)	I-Sheng Manufacture (songgang) Factory	H05VV-F 60227 IEC 53	3G1,0mm ² (Length < 2m)	K60227-5(2011-12)	KC SU01015- 4001
Alternative	Ningbo Qiaopu Electric Co., Ltd.	H05VV-F 60227 IEC 53	3G1,0mm ² (Length < 2m)	K60227-5(2011-12)	KC SU01035- 5002B
Alternative	Guangdong Xiongrun Electrical Co., Ltd	H05VV-F 60227 IEC 53	3G1,0mm ² (Length < 2m)	K60227-5(2011-12)	KC HU01034- 10003A
Alternative	Guangdong Yincheng Electric Appliance Co., Ltd.	H05VV-F 60227 IEC 53	3G1,0mm ² (Length < 2m)	K60227-5(2011-12)	KC SU01113- 14001
Alternative	I-Sheng Manufacture (Songgang) Factory	H05VV-F 60227 IEC 53	3G1,5mm ² (Length < 2m)	K60227-5(2011-12)	KC SU01015- 4001
Alternative	Ningbo Qiaopu Electric Co., Ltd.	H05VV-F 60227 IEC 53	3G1,5mm ² (Length < 2m)	K60227-5(2011-12)	KC SU01035- 5002B

IEC 60335-2-15					
Clause	Requirement + Test			Result - Remark	Verdict
Alternative	Guangdong Xiongrun Electrical Co., Ltd	H05VV-F 60227 IEC 53	3G1,5mm ² (Length < 2m)	K60227-5(2011-12)	KC HU01034- 10003A
Alternative	Guangdong Yincheng Electric Appliance Co., Ltd.	H05VV-F 60227 IEC 53	3G1,5mm ² (Length < 2m)	K60227-5(2011-12)	KC SU01113- 14001
Power cord for AU (for models not more than 3500W)	Shenzhen Tongyuan Industrial Co., Ltd	H05VV-F	3G1,0mm ² (Length < 2m)	AS/NZS3191:2003	NSW 24638
Alternative	Shangyu Jintao Electron Co., Ltd.	H05VV-F	3G1,0mm ² (Length < 2m)	AS/NZS3191:2003	SAA ESO120467/0 0
Alternative	Guangdong Xiongrun Electrical Co., Ltd	H05VV-F	3G1,0mm ² (Length < 2m)	AS/NZS3191:2003	SAA ESO130530/0 0
Alternative	Yuyao Zhongjian Electric Appliance Co., Ltd.	H05VV-F	3G1,0mm ² (Length < 2m)	AS/NZS3191:2003	SAA-161393- EA
Alternative	Shenzhen Tongyuan Industrial Co., Ltd	H05VV-F	3G1,5mm ² (Length < 2m)	AS/NZS3191:2003	NSW 24638
Alternative	Shangyu Jintao Electron Co., Ltd.	H05VV-F	3G1,5mm ² (Length < 2m)	AS/NZS3191:2003	SAA ESO120467/0 0
Alternative	Guangdong Xiongrun Electrical Co., Ltd	H05VV-F	3G1,5mm ² (Length < 2m)	AS/NZS3191:2003	SAA ESO130530/0 0
Alternative	Yuyao Zhongjian Electric Appliance Co., Ltd.	H05VV-F	3G1,5mm ² (Length < 2m)	AS/NZS3191:2003	SAA-161393- EA
Power cord for Indonesia (for models not more than 3500W)	Guangdong Xiongrun Electrical Co., Ltd	H05VV-F	3G1,0mm ² (Length < 2m)	SNI 04-6629.1: 2006 SNI 04-6629.2: 2006 SNI 04-6629.5: 2006	079 127-12
Alternative	Guangdong Yincheng Electric Appliance Co., Ltd.	H05VV-F	3G1,0mm ² (Length < 2m)	SNI 04-6629.1: 2006 SNI 04-6629.2: 2006 SNI 04-6629.5: 2006	SNI 04-3892.1
Alternative	Guangdong Xiongrun Electrical Co. Ltd	H05VV-F	3G1,0mm ² (Length < 2m)	SNI 04-6629.1: 2006 SNI 04-6629.2: 2006 SNI 04-6629.5: 2006	SNI 04-6629.5
Alternative	Guangdong Yincheng Electric Appliance Co., Ltd.	H05VV-F	3G1,5mm ² (Length < 2m)	SNI 04-6629.1: 2006 SNI 04-6629.2: 2006 SNI 04-6629.5: 2006	SNI
Alternative	Guangdong Xiongrun Electrical Co. Ltd	H05VV-F	3G1,5mm ² (Length < 2m)	SNI 04-6629.1: 2006 SNI 04-6629.2: 2006 SNI 04-6629.5: 2006	SNI 04-6629.5

IEC 60335-2-15					
Clause	Requirement + Test			Result - Remark	Verdict
Power cord (for models not more than 3500W, Not for CE, GS)	Guangdong Yincheng Electric Appliance Co., Ltd.	60227 IEC 53(RVV) 300/500V	3G1,0mm ² (Length < 2m)	GB/T 5023.5-2008 IEC 60227-5:2003	CCC 20020101050 13874
Alternative	Lianjiang Yinsheng Electric Factory	60227 IEC 53(RVV) 300/500V	3G1,0mm ² (Length < 2m)	GB/T 5023.5-2008 IEC 60227-5:2003	CCC 20150101058 05461
Alternative	Guangdong Zhongxing Electric Co., Ltd.	60227 IEC 53(RVV) 300/500V	3G1,0mm ² (Length < 2m)	GB/T 5023.5-2008 IEC 60227-5:2003	CCC 20110101055 07200
Alternative	Maoming Maogang Jiada Electrical Appliance Factory	60227 IEC 53(RVV) 300/500V (Min)	3G1,0mm ² (Length < 2m)	GB/T 5023.5-2008 IEC 60227-5:2003	CCC 20140101057 12143
Alternative	Guangdong Yincheng Electric Appliance Co., Ltd.	60227 IEC 53(RVV) 300/500V	3G1,5mm ² (Length < 2m)	GB/T 5023.5-2008 IEC 60227-5:2003	CCC 20020101050 13874
Alternative	Lianjiang Yinsheng Electric Factory	60227 IEC 53(RVV) 300/500V	3G1,5mm ² (Length < 2m)	GB/T 5023.5-2008 IEC 60227-5:2003	CCC 20150101058 05461
Alternative	Guangdong Zhongxing Electric Co., Ltd.	60227 IEC 53(RVV) 300/500V	3G1,5mm ² (Length < 2m)	GB/T 5023.5-2008 IEC 60227-5:2003	CCC 20110101055 07200
Connector (for models not more than 1300W)	Guangdong Yincheng Electric Appliance Co. Ltd.	YC-L10	AC 250V, 10A	EN 60320-1:2015 IEC 60320-1:2015	VDE 40027508
Alternative	Zhanjiang Anjia Electronics Industry Co., Ltd.	AJ-06	AC250V, 10A	EN 60320-1:2015 IEC 60320-1:2015	VDE 40034404
Alternative	Zhanjiang Yexing Electrical Appliance Co., Ltd	YX304	AC250V, 10A	EN 60320-1:2015 IEC 60320-1:2015	VDE 40029055
Alternative	Kenic Electric Mfg Co., Ltd	KE-24	AC250V, 10A	EN 60320-1:2015 IEC 60320-1:2015	VDE 40003450
Alternative	Lian Dung Electric Wire Material Co., Ltd.	LT-501	AC250V, 10A	EN 60320-1:2015 IEC 60320-1:2015	VDE 40013379
Alternative	Guangdong Xiongrun Electrical Co., Ltd	XR-501	AC250V, 10A	EN 60320-1:2015 IEC 60320-1:2015	VDE 40038969
Alternative	Yuyao Zhongjian Electric Appliance Co., Ltd.	ZT3	AC250V, 10A	EN 60320-1:2015 IEC 60320-1:2015	VDE 40047516
Alternative	Guangdong Xiongrun Electrical Co., Ltd	XR-501	AC250V, 10A	EN 60320-1:2015 IEC 60320-1:2015	ENEC CA02.04843
Alternative	Guangdong Xiongrun Electrical Co., Ltd	XR-501	AC250V, 10A	EN 60320-1:2015 IEC 60320-1:2015	ESO120715/0 0

IEC 60335-2-15					
Clause	Requirement + Test			Result - Remark	Verdict
Connector for Korea (for models not more than 1300W)	Guangdong Xiongrun Electrical Co., Ltd	XR-501	AC250V, 10A	K60320-1(2010-12)	KC HU0407-13003A
Alternative	Guangdong Yincheng Electric Appliance Co., Ltd.	YCH-10	AC250V, 10A	K60320-1(2010-12)	KC SU04172-14001
Connector (for models not more than 1300W, Not for CE, GS)	Guangdong Yincheng Electric Appliance Co., Ltd.	YC-10	AC250V, 10A	GB17465.1-2009 IEC60320-1:2007	CCC 20020102040 19069
Alternative	Lianjiang Yinsheng Electric Factory	YS-10	AC250V, 10A	GB17465.1-2009 IEC60320-1:2007	CCC 20150102047 97339
Alternative	Guangdong Zhongxing Electric Co., Ltd.	ZX-10	AC250V, 10A	GB17465.1-2009 IEC60320-1:2007	CCC 20110102044 99009
Alternative	Maoming Maogang Jiada Electrical Appliance Factory	JD310+JD-10	AC250V, 10A	GB17465.1-2009 IEC60320-1:2007	CCC 20140101017 11940
Inlet (for models not more than 1300W)	Zhang Jia Gang Hua Feng Electronic Connector & Component Co., Ltd.	HF-301	AC250V, 10A	EN 60320-1:2015 IEC 60320-1:2015	VDE 40005132
Alternative	Steady Electronics Corporation	2107	AC250V, 10A	EN 60320-1:2015 IEC 60320-1:2015	VDE 40011923
Alternative	Zhe Jiang Bei Er Electronic Co., Ltd.	ST-A02	AC250V, 10A	EN 60320-1:2015 IEC 60320-1:2015	VDE 40007930
Alternative	Zhe Jiang Bei Er Electronic Co., Ltd.	ST-A01 series	AC250V, 10A	EN 60320-1:2015 IEC 60320-1:2015	VDE 40013388
Alternative	Jackson Electronics Ind. Corp.	JR-101	AC250V, 10A	EN 60320-1:2015 IEC 60320-1:2015	VDE 40010178
Alternative	YUEQING YANHUI ELECTRONIC CO.,LTD	DB-14	AC250V, 10A	EN 60320-1:2015 IEC 60320-1:2015	VDE 40032008
Inlet (for models not more than 1300W, Not for CE, GS)	Guangdong Yincheng Electric Appliance Co., Ltd.	P-2	AC250V, 10A	GB17465.1-2009 IEC60320-1:2007	CCC 20030102040 34027
Alternative	Zhanjiang Yexing Electrical Appliance Co., Ltd	P-3A, P-3B	AC250V, 10A	GB17465.1-2009 IEC60320-1:2007	CCC 20020102040 08984

IEC 60335-2-15					
Clause	Requirement + Test		Result - Remark		Verdict
Alternative	LIANJIANG CITY YANGZHOU ELECTRICAL APPLIANCE FACTORY	YZ-01	AC250V, 10A	GB17465.1-2009 IEC60320-1:2007	CCC 20100102043 88776
Alternative	Lianjiang HUAXI Electrical Appliance Factory	HX	AC250V, 10A	GB17465.1-2009 IEC60320-1:2007	CCC 20090102043 68772
Alternative	YUEQING YANHUI ELECTRONIC CO.,LTD	DB-14	AC250V, 10A	GB17465.1-2009 IEC60320-1:2007	Ccc 20100102043 88773
Thermal link (for models not more than 550W in RC series)	NEC SCHOTT Components Corporation	SF188E	AC250V, 10A or 15A Tf192	EN60691:2003+A1:2 007+A2: 2010 IEC 60691:2002+ A1:2006 +A2:2010	VDE 40006568
Alternative	Therm-O-Disc Europe B.V	G4Axx192C, G6Axx192C	AC250V, 10A or 16A Tf192	EN60691:2003+A1:2 007+A2: 2010 IEC 60691:2002+ A1:2006 +A2:2010	VDE 40017228
Alternative	Zhongshan Sheng Ping Thermal Protectors Co., Ltd.	SPF188	AC250V, 10A or 16A Tf192	EN60691:2003+A1:2 007+A2: 2010 IEC 60691:2002+ A1:2006 +A2:2010	VDE 40004430
Alternative	Aupo Electronics Ltd	BF192	AC250V, 10A or 16A Tf192	EN60691:2003+A1:2 007+A2: 2010 IEC 60691:2002+ A1:2006 +A2:2010	VDE 40005418
Alternative	Zhongshang Longde Electrical Co., Ltd.	RY192	AC250V, 10A Tf192	EN60691:2003+A1:2 007+A2: 2010 IEC 60691:2002+ A1:2006 +A2:2010	TUV SUD B1305674460 21
Alternative	Zhongshan City Haoweishi Electrical Appliance Co., Ltd	RY Tf 192°C	AC250V, 10A or 15A Tf192	EN60691:2003+A1:2 007+A2: 2010 IEC 60691:2002+ A1:2006 +A2:2010	TUV Rh R 50252801
Alternative	Dongguan Better Electronics Technology Co., Ltd	BBT192C	AC250V, 10A or 15A Tf192	EN60691:2003+A1:2 007+A2: 2010 IEC 60691:2002+ A1:2006 +A2:2010	VDE 40041299
Thermal link for Korea (for models not more than 550W in RC series)	Dongguan Better Electronics Technology Co., Ltd	BBT	AC250V, 10A or 15A Tf192	K60691(2008-12)	KC SU05042- 14006
Alternative	Zhangzhou Aupo Electronics Co., Ltd.	BF192	AC 250V, 10A, Tf192	K60691(2008-12)	KC SU05017- 11004

IEC 60335-2-15					
Clause	Requirement + Test		Result - Remark		Verdict
Thermal link (for models not more than 550W in RC series, Not for CE, GS)	Nanhai Changcai Electric Component factory	RF	AC250V, 10A or 15A, Tf192,	GB9816:2013 IEC 60691:2002	CCC 20030102050 29016
Alternative	Zhongshan Shengping Thermal Protector Co., Ltd	RY	AC250V, 10A or 16A, Tf192,	GB9816:2013 IEC 60691:2002	CCC 20020102050 09034
Alternative	Aupo Electronics Ltd	BF	AC 250V, 10A, Tf192,	GB9816:2013 IEC 60691:2002	CCC 20030102050 52188
Alternative	Zhongshan Longde Electrical Co., Ltd.	RY	AC250V, 10A or 15A, Tf192,	GB9816:2013 IEC 60691:2002	CCC 20090102053 49141
Alternative	Lianjiang Shiling Jiabao Electrical Components Plant	RF	AC250V, 10A or 15A, Tf192,	GB9816:2013 IEC 60691:2002	CCC 20090102053 66216
Thermal link (for models 600W-2200W in RC series)	NEC SCHOTT Components Corporation	SF214E	AC250V, 10A or 15A, Tf216,	EN60691:2003+A1:2007+A2: 2010 IEC 60691:2002+A1:2006 +A2:2010	VDE 40006568
Alternative	Therm-O-Disc Europe B.V	G4Axx	AC 250V, 10A, Tf216,	EN60691:2003+A1:2007+A2: 2010 IEC 60691:2002+A1:2006 +A2:2010	VDE 40017228
Alternative	Therm-O-Disc Europe B.V	G6Axx	AC 250V, 16A, Tf216,	EN60691:2003+A1:2007+A2: 2010 IEC 60691:2002+A1:2006 +A2:2010	VDE 40017228
Alternative	Zhongshan Sheng Ping Thermal Protectors Co., Ltd.	SPF214	AC 250V, 10A, Tf216	EN60691:2003+A1:2007+A2: 2010 IEC 60691:2002+A1:2006 +A2:2010	VDE 40004430
Alternative	Zhongshan Sheng Ping Thermal Protectors Co., Ltd.	SPF214H	AC 250V, 16A, Tf216	EN60691:2003+A1:2007+A2: 2010 IEC 60691:2002+A1:2006 +A2:2010	VDE 40016445
Alternative	Aupo Electronics Ltd	BF216	AC250V, 10A or 16A, Tf216	EN60691:2003+A1:2007+A2: 2010 IEC 60691:2002+A1:2006 +A2:2010	VDE 40005418
Alternative	Zhongshang Longde Electrical Co., Ltd.	RY216	AC 250V, 10A, Tf216	EN60691:2003+A1:2007+A2: 2010 IEC 60691:2002+A1:2006 +A2:2010	TUV SUD B1305674460 21
Alternative	Dongguan Better Electronics Technology Co., Ltd	BBT216C	AC250V, 10A or 15A, Tf216	EN60691:2003+A1:2007+A2: 2010 IEC 60691:2002+A1:2006 +A2:2010	VDE 40041299

IEC 60335-2-15					
Clause	Requirement + Test			Result - Remark	Verdict
Alternative	Zhongshan City Haoweishi Electrical Appliance Co., Ltd	RY Tf 216°C	AC250V, 10A or 15A, T246, Tf216	EN60691:2003+A1:2007+A2: 2010 IEC 60691:2002+A1:2006 +A2:2010	TUV Rh R 50252801
Thermal link for Korea (for models 600W-2200W in RC series)	Dongguan Better Electronics Technology Co., Ltd	BBT	AC250V, 15A, Tf216	K60691(2008-12)	KC SU05042-14002
Alternative	Zhangzhou Aupo Electronics Co., Ltd.	BF216	AC 250V, 10A, Tf216	K60691(2008-12)	KC SU05017-11005
Thermal link for (for models 600W-2200W in RC series, not for GS, CE)	Nanhai Changcai Electric Component Factory	RF	AC250V, 10A or 15A or 20A, Tf216	GB9816:2013 IEC 60691:2002	CCC 20030102050 29016
Alternative	Zhongshan Shengping Thermal Protector Co., Ltd	RY	AC250V, 10A or 16A, Tf216	GB9816:2013 IEC 60691:2002	CCC 20020102050 09034
Alternative	Aupo Electronics Ltd	BF216	AC 250V, 10A, Tf216	GB9816:2013 IEC 60691:2002	CCC 20030102050 52188
Alternative	Zhongshan Longde Electrical Co., Ltd.	RY	AC250V, 10A or 15A, Tf216,	GB9816:2013 IEC 60691:2002	CCC 20090102053 49141
Alternative	Lianjiang Shiling Jiabao Electrical Components Plant	RF	AC250V, 10A or 15A or 20A, Tf216	GB9816:2013 IEC 60691:2002	CCC 20090102053 66216
Thermal link (for models of 2250W-3250W)	NEC SCHOTT Components Corporation	SF214E	AC 250V, 15A, Tf216	EN60691:2003+A1:2007+A2: 2010 IEC 60691:2002+A1:2006 +A2:2010	VDE 40006568
Alternative	Therm-O-Disc Europe B.V	G6Axx216C	AC 250V, 16A, Tf216	EN60691:2003+A1:2007+A2: 2010 IEC 60691:2002+A1:2006 +A2:2010	VDE 40017228
Alternative	Zhongshan Sheng Ping Thermal Protectors Co., Ltd.	SPF214H	AC 250V, 16A, Tf216	EN60691:2003+A1:2007+A2: 2010 IEC 60691:2002+A1:2006 +A2:2010	VDE 40016445
Alternative	Aupo Electronics Ltd	BF216	AC250V, 16A, Tf216	EN60691:2003+A1:2007+A2: 2010 IEC 60691:2002+A1:2006 +A2:2010	VDE 40005418
Alternative	Dongguan Better Electronics Technology Co., Ltd	BBT216C	AC250V, 15A, Tf216	EN60691:2003+A1:2007+A2: 2010 IEC 60691:2002+A1:2006 +A2:2010	VDE 40041299

IEC 60335-2-15					
Clause	Requirement + Test			Result - Remark	Verdict
Alternative	Lianjiang City Haoweishi Electrical Appliance Factory	RY Tf 216°C	AC250V, 15A, Tf216	EN60691:2003+A1:2007+A2: 2010 IEC 60691:2002+A1:2006 +A2:2010	TUV Rh R 50252801
Thermal link for Korea (for models of 2250W-3250W)	Dongguan Better Electronics Technology Co., Ltd	BBT	AC250V, 15A, Tf216	K60691(2008-12)	KC SU05042-14002
Thermal link (for models of 2250W-3250W, Not for CE, GS)	Nanhai Changcai Electric Component Factory	RF	AC250V, 15A or 20A, Tf216	GB9816:2013 IEC 60691:2002	CCC 20030102050 29016
Alternative	Zhongshan Sheng Ping Thermal Protectors Co., Ltd.	RY	AC 250V, 16A, Tf216	GB9816:2013 IEC 60691:2002	CCC 20020102050 09034
Alternative	Zhongshang Longde Electrical Co., Ltd.	RY	AC 250V, 15A, Tf216	GB9816:2013 IEC 60691:2002	CCC 20090102053 49141
Alternative	Lianjiang Shiling Jiabao Electrical Components Plant	RF	AC250V, 15Aor 20A, Tf216	GB9816:2013 IEC 60691:2002	CCC 20090102053 66216
Thermal link (for models of 3500W)	Therm-O-Disc Europe B.V	G6 (Series)	AC 250V, 16A, Tf216	EN60691:2003+A1:2007+A2: 2010 IEC 60691:2002+A1:2006 +A2:2010	VDE 40017228
Alternative	Zhongshan Sheng Ping Thermal Protectors Co., Ltd.	SPF214H	AC 250V, 16A, Tf216	EN60691:2003+A1:2007+A2: 2010 IEC 60691:2002+A1:2006 +A2:2010	VDE 40016445
Alternative	Aupo Electronics Ltd	BF216	AC250V, 16A, Tf216	EN60691:2003+A1:2007+A2: 2010 IEC 60691:2002+A1:2006 +A2:2010	VDE 40005418
Thermal link (for models of 3500W, Not for CE, GS)	Nanhai Changcai Electric Component Factory	RF	AC 250V, 20A, Tf216	GB9816:2013 IEC 60691:2002	CCC 20030102050 29016
Alternative	Zhongshan Sheng Ping Thermal Protectors Co., Ltd.	RY	AC 250V, 16A, Tf216	GB9816:2013 IEC 60691:2002	CCC 20020102050 09034
Alternative	Lianjiang Shiling Jiabao Electrical Components Plant	RF	AC 250V, 20A, Tf216	GB9816:2013 IEC 60691:2002	CCC 20090102053 66216
Thermal link (for models not more than 550W in SRC series)	NEC SCHOTT Components Corporation	SF184E or SF188E	AC250V, 10A or 15A, Tf184 or Tf192	EN60691:2003+A1:2007+A2: 2010 IEC 60691:2002+A1:2006 +A2:2010	VDE 40006568

IEC 60335-2-15					
Clause	Requirement + Test			Result - Remark	Verdict
Alternative	Therm-O-Disc Europe B.V	G4Axx184C, or G4Axx192C	AC250V, 10A, Tf184 or Tf192	EN60691:2003+A1:2007+A2:2010 IEC 60691:2002+A1:2006 +A2:2010	VDE 40017228
Alternative	Therm-O-Disc Europe B.V	G6Axx184C or G6Axx192C	AC250V, 16A, Tf184 or Tf192	EN60691:2003+A1:2007+A2:2010 IEC 60691:2002+A1:2006 +A2:2010	VDE 40017228
Alternative	Zhongshan Sheng Ping Thermal Protectors Co., Ltd.	SPF182 or SPF188	AC250V, 10A or 16A, Tf184 or Tf192	EN60691:2003+A1:2007+A2:2010 IEC 60691:2002+A1:2006 +A2:2010	VDE 40004430
Alternative	Aupo Electronics Ltd	BF184 or BF192	AC250V, 10A or 16A, Tf184 or Tf192	EN60691:2003+A1:2007+A2:2010 IEC 60691:2002+A1:2006 +A2:2010	VDE 40005418
Alternative	Zhongshang Longde Electrical Co., Ltd.	RY184 or RY192	AC250V, 10A, Tf184 or Tf192	EN60691:2003+A1:2007+A2:2010 IEC 60691:2002+A1:2006 +A2:2010	TUV SUD B1305674460 21
Alternative	Zhongshan City Haoweishi Electrical Appliance Co., Ltd	RY Tf 184°C or RY Tf 192°C	AC250V, 10A or 15A, Tf184 or Tf192	EN60691:2003+A1:2007+A2:2010 IEC 60691:2002+A1:2006 +A2:2010	TUV Rh R 50252801
Alternative	Dongguan Better Electronics Technology Co., Ltd	BBT184C or BBT192C	AC250V, 10A or 15A, Tf184 or Tf192	EN60691:2003+A1:2007+A2:2010 IEC 60691:2002+A1:2006 +A2:2010	VDE 40041299
Thermal link for Korea (for models not more than 550W in SRC series)	Zhangzhou Aupo Electronics Co., Ltd.	BF184 or BF192	AC 250V, 10A, Tf184 or Tf192	K60691(2008-12)	KC SU05017-11004
Thermal link (for models not more than 550W in SRC series, Not for CE, GS)	Nanhai Changcai Electric Component factory	RF	AC250V, 10A or 15A, Tf185 or Tf192	GB9816:2013 IEC 60691:2002	CCC 20030102050 29016
Alternative	Zhongshan Shengping Thermal Protector Co., Ltd	RY184 or RY192	AC250V, 10A or 16A, Tf184 or Tf192	GB9816:2013 IEC 60691:2002	CCC 20020102050 09034
Alternative	Aupo Electronics Ltd	BF184 or BF192	AC 250V, 10A, Tf184 or Tf192	GB9816:2013 IEC 60691:2002	CCC 20030102050 52188
Alternative	Zhongshan Longde Electrical Co., Ltd.	RY	AC250V, 10A or 15A, Tf185 or Tf192	GB9816:2013 IEC 60691:2002	CCC 20090102053 49141
Alternative	Lianjiang Shiling Jiabao Electrical Components Plant	RF	AC250V, 10A or 15A, Tf185 or Tf192	GB9816:2013 IEC 60691:2002	CCC 20090102053 66216

IEC 60335-2-15					
Clause	Requirement + Test			Result - Remark	Verdict
Thermal link (for models 600W-1000W in SRC series)	NEC SCHOTT Components Corporation	SF184E or SF214E	AC250V, 10A or 15A, Tf184 or Tf216	EN60691:2003+A1:2007+A2:2010 IEC 60691:2002+A1:2006 +A2:2010	VDE 40006568
Alternative	Therm-O-Disc Europe B.V	G4Axx184C, or G4Axx216C	AC 250V, 10A, Tf184 or Tf216	EN60691:2003+A1:2007+A2:2010 IEC 60691:2002+A1:2006 +A2:2010	VDE 40017228
Alternative	Therm-O-Disc Europe B.V	G6Axx184C or G6Axx216C	AC 250V, 16A, Tf184 or Tf216	EN60691:2003+A1:2007+A2:2010 IEC 60691:2002+A1:2006 +A2:2010	VDE 40017228
Alternative	Zhongshan Sheng Ping Thermal Protectors Co., Ltd.	SPF184 or SPF214	AC 250V, 10A, Tf184 or Tf216	EN60691:2003+A1:2007+A2:2010 IEC 60691:2002+A1:2006 +A2:2010	VDE 40004430
Alternative	Zhongshan Sheng Ping Thermal Protectors Co., Ltd.	SPF182H or SPF214H	AC 250V, 16A, Tf184 or Tf216	EN60691:2003+A1:2007+A2:2010 IEC 60691:2002+A1:2006 +A2:2010	VDE 40016445
Alternative	Aupo Electronics Ltd	BF184 or BF216	AC250V, 10A or 16A, Tf184 or Tf216	EN60691:2003+A1:2007+A2:2010 IEC 60691:2002+A1:2006 +A2:2010	VDE 40005418
Alternative	Zhongshang Longde Electrical Co., Ltd.	RY184 or RY216	AC 250V, 10A, Tf184 or Tf216	EN60691:2003+A1:2007+A2:2010 IEC 60691:2002+A1:2006 +A2:2010	TUV SUD B1305674460 21
Alternative	Dongguan Better Electronics Technology Co., Ltd	BBT184C or BBT216C	AC250V, 10A or 15A, Tf184 or Tf216	EN60691:2003+A1:2007+A2:2010 IEC 60691:2002+A1:2006 +A2:2010	VDE 40041299
Alternative	Zhongshan City Haoweishi Electrical Appliance Co., Ltd	RY Tf 216°C	AC250V, 10A or 15A, Tf184 or Tf216	EN60691:2003+A1:2007+A2:2010 IEC 60691:2002+A1:2006 +A2:2010	TUV Rh R 50252801
Thermal link for Korea (for models 600W-1000W in SRC series)	Dongguan Better Electronics Technology Co., Ltd	BBT	AC250V, 15A, Tf184 or Tf216	K60691(2008-12)	KC SU05042-14002
Alternative	Zhangzhou Aupo Electronics Co., Ltd.	BF184 or BF216	AC 250V, 10A, Tf184 or Tf216	K60691(2008-12)	KC SU05017-11005
Thermal link for (for models 600W-1000W in SRC series, not for GS, CE)	Nanhai Changcai Electric Component Factory	RF	AC250V, 10A or 15A or 20A, Tf185 or Tf216	GB9816:2013 IEC 60691:2002	CCC 20030102050 29016

IEC 60335-2-15					
Clause	Requirement + Test			Result - Remark	Verdict
Alternative	Zhongshan Shengping Thermal Protector Co., Ltd	RY184 or RY216	AC250V, 10A or 16A, Tf184 or Tf216	GB9816:2013 IEC 60691:2002	CCC 20020102050 09034
Alternative	Aupo Electronics Ltd	BF184 or BF216	AC 250V, 10A, Tf184 or Tf216	GB9816:2013 IEC 60691:2002	CCC 20030102050 52188
Alternative	Zhongshan Longde Electrical Co., Ltd.	RY	AC250V, 10A or 15A, Tf185 or Tf216	GB9816:2013 IEC 60691:2002	CCC 20090102053 49141
Alternative	Lianjiang Shiling Jiabao Electrical Components Plant	RF	AC250V, 10A or 15A or 20A, Tf185 or Tf216	GB9816:2013 IEC 60691:2002	CCC 20090102053 66216
Thermal link (for models DRC series)	NEC SCHOTT Components Corporation	SF152E	AC250V, 10A or 15A, Tf157	EN60691:2003+A1:2 007+A2: 2010 IEC 60691:2002+ A1:2006 +A2:2010	VDE 40006568
Alternative	NEC SCHOTT Components Corporation	SF169E	AC250V, 10A or 15A, Tf172	EN60691:2003+A1:2 007+A2: 2010 IEC 60691:2002+ A1:2006 +A2:2010	VDE 40006568
Alternative	Therm-O-Disc Europe B.V	G4Axx158C	AC 250V, 10A, Tf158,	EN60691:2003+A1:2 007+A2: 2010 IEC 60691:2002+ A1:2006 +A2:2010	VDE 40017228
Alternative	Therm-O-Disc Europe B.V	G6Axx167C	AC 250V, 16A, Tf167	EN60691:2003+A1:2 007+A2: 2010 IEC 60691:2002+ A1:2006 +A2:2010	VDE 40017228
Alternative	Zhongshan Sheng Ping Thermal Protectors Co., Ltd.	SPF152 or SPF169	AC250V, 10A, Tf157 or Tf167	EN60691:2003+A1:2 007+A2: 2010 IEC 60691:2002+ A1:2006 +A2:2010	VDE 40004430
Alternative	Aupo Electronics Ltd	BF157 or BF172	AC250V, 10A or 16A, Tf157 or Tf172	EN60691:2003+A1:2 007+A2: 2010 IEC 60691:2002+ A1:2006 +A2:2010	VDE 40005418
Alternative	Zhongshan Longde Electrical Co., Ltd.	RY157 or RY167	AC 250V, 10A, Tf157 or Tf167	EN60691:2003+A1:2 007+A2: 2010 IEC 60691:2002+ A1:2006 +A2:2010	TUV B1305674460 21
Alternative	Lianjiang City Haoweishi Electrical Appliance Factory	RY157 or RY165 or RY167	AC250V, 10A or/15A, Tf157 or Tf165 or Tf167	EN60691:2003+A1:2 007+A2: 2010 IEC 60691:2002+ A1:2006 +A2:2010	TUV R 50252801
Alternative	Dongguan Better Electronics Technology Co., Ltd	BBT157C or BBT167C	AC250V, 10A or15A, Tf157 or Tf167	EN60691:2003+A1:2 007+A2: 2010 IEC 60691:2002+ A1:2006 +A2:2010	VDE 40041299
Thermal link For Korea (for models DRC series)	Dongguan Better Electronics Technology Co., Ltd	BBT	AC 250V, 10A Tf157	K60691(2008-12)	KC SU05042- 14005

IEC 60335-2-15					
Clause	Requirement + Test		Result - Remark		Verdict
Alternative	Aupo Electronics Ltd	BF157	AC 250V, 10A, Tf157,	K60691(2008-12)	KC SU05017-11003
Thermal link (for models DRC series, Not for CE, GS)	Nanhai Changcai Electric Component Factory	RF	AC250V,10A or 15A, Tf165	GB9816:2013 IEC 60691:2002	CCC 20030102050 29016
Alternative	Zhongshan Shengping Thermal Protector Co., Ltd	RY157 or RY167	AC250V,10A or 16A, Tf157 or Tf167	GB9816:2013 IEC 60691:2002	CCC 20020102050 09034
Alternative	Aupo Electronics Ltd	BF157	AC 250V, 10A, Tf157	GB9816:2013 IEC 60691:2002	CCC 20030102050 52188
Alternative	Zhongshan Longde Electrical Co., Ltd.	RY	AC250V, 10A or 15A, Tf165	GB9816:2013 IEC 60691:2002	CCC 20090102053 49141
Alternative	Lianjiang Shiling Jiabao Electrical Components Plant	RF	AC250V, 10A or 15A, Tf165	GB9816:2013 IEC 60691:2002	CCC 20090102053 66216
Thermostat (used for Keep warm function) (for models not more than 2200W)	Zhongshan Huilong Electrical Co. Ltd.	KST 101-A, KST 101-B, KST 101-C	AC 250V, 10A, T220, Tf73	EN 60730-1:2011 EN 60730-2-9:2010 IEC 60730-1:2010 IEC 60730-2-9:2008	VDE 40022487
Alternative	Foshan Shunde Kaiyi Thermostat Co., Ltd	JT-208A, JT-208B, JT-208C, JT-208D	AC 250V, 10A, T270, Tf73	EN 60730-1:2011 EN 60730-2-9:2010 IEC 60730-1:2010 IEC 60730-2-9:2008	TUV Rh R50196799
Alternative	Foshan Nanhai Tengya Electric Appliance Co., Ltd.	KST-801G	AC250V, 16A, T280, Tf73	EN 60730-1:2011 EN 60730-2-9:2010 IEC 60730-1:2010 IEC 60730-2-9:2008	TUV Rh R50161212
Alternative	Foshan Nanhai Tengya Electric Appliance Co., Ltd.	KST-801A, KST-801B, KST-801C, KST-801D, KST-801F	AC 250V, 10A T280, Tf73	EN 60730-1:2011 EN 60730-2-9:2010 IEC 60730-1:2010 IEC 60730-2-9:2008	TUV Rh R50161212
Alternative	Shenzhen Forever Great Technology Co., Ltd.	WK-03	AC 250V, 16A, Tf73, T300	EN 60730-1:2011 EN 60730-2-9:2010 IEC 60730-1:2010 IEC 60730-2-9:2008	VDE 40006682

IEC 60335-2-15					
Clause	Requirement + Test		Result - Remark		Verdict
Thermostat (used for Keep warm function, for models not more than 2200W, Not for CE, GS)	Zhongshan Huilong Electrical Co., Ltd.	KSD101	AC250V, 10A or 15A, Tf73, T250	GB14536.1:2008 GB14536.10:2008 IEC 60730- 1:1999+A1:2003 IEC 60730: 2000+A1+A2	CQC 03002005357
Thermostat (for Keep warm function) (for models not more than 3250W)	Foshan Nanhai Tengya Electric Appliance Co., Ltd.	KST-801G	AC 250V, 16A, T260, Tf73	EN 60730-1:2011 EN 60730-2-9:2010 IEC 60730-1:2010 IEC 60730-2-9:2008	TUV Rh R50161212
Alternative	Shenzhen Forever Great Technology Co., Ltd.	WK-03	AC 250V, 16A, Tf73, T300	EN 60730-1:2011 EN 60730-2-9:2010 IEC 60730-1:2010 IEC 60730-2-9:2008	VDE 40006682
Thermostat (for Keep warm function, for models not more than 3250W, Not for CE, GS)	Zhongshan Huilong Electrical Co., Ltd.	KSD101	AC 250V, 15A or 20A, Tf73, T250	GB14536.1:2008 GB14536.10:2008 IEC 60730- 1:1999+A1:2003 IEC 60730: 2000+A1+A2	CQC 03002005357
Thermostat (for Keep warm function) (for models of 3500W)	Foshan Nanhai Tengya Electric Appliance Co., Ltd.	KST-801G	AC 250V, 16A, T260, Tf73	EN 60730-1:2011 EN 60730-2-9:2010 IEC 60730-1:2010 IEC 60730-2-9:2008	TUV Rh R50161212
Alternative	Shenzhen Forever Great Technology Co., Ltd.	WK-03	AC 250V, 16A, Tf73, T300	EN 60730-1:2011 EN 60730-2-9:2010 IEC 60730-1:2010 IEC 60730-2-9:2008	VDE 40006682
Thermostat (for Keep warm function, for models of 3500W, Not for CE, GS)	Zhongshan Huilong Electrical Co., Ltd.	KSD101	AC250V, 20A, Tf73, T250	GB14536.1:2008 GB14536.10:2008 IEC 60730- 1:1999+A1:2003 IEC 60730: 2000+A1+A2	CQC 03002005357

IEC 60335-2-15					
Clause	Requirement + Test			Result - Remark	Verdict
Thermal cut-out (for models not more than 2200W)	Guangdong Shunde Zhongbao Thermostat Technology Co., Ltd.	KSD301- Cy	AC250V, 10A or 15A or 16A, T270, Tf170 or Tf180, 1E4	EN 60730-1:2011 EN 60730-2-9:2010 IEC 60730-1:2010 IEC 60730-2-9:2008	TUV R 50114187
Alternative	Foshan Tianpeng Thermostat Co., Ltd.	T1/33 series	AC250V, 10A or 16A, T210, Tf170 or Tf180, 3E4	EN 60730-1:2011 EN 60730-2-9:2010 IEC 60730-1:2010 IEC 60730-2-9:2008	VDE 40019583
Alternative	Foshan Tianpeng Thermostat Co., Ltd.	T1/33	AC250V, 10A or 16A, Tf170 or Tf180, T210, 1E4	EN 60730-1:2011 EN 60730-2-9:2010 IEC 60730-1:2010 IEC 60730-2-9:2008	TUV Rh R50091107
Alternative	Zhongshan Huilong Electrical Co., Ltd.	KSD301G	AC250V, 10A or 16A, Tf170 or Tf180, T300, 6E4	EN 60730-1:2011 EN 60730-2-9:2010 IEC 60730-1:2010 IEC 60730-2-9:2008	VDE 40034938
Thermal cut-out for models not more than 2200W, Not for CE, GS)	Zhongshan Huilong Electrical Co., Ltd.	KSD301G	AC250V, 10A/16A, Tf170 or Tf180, T300, 6E4	GB14536.1:2008 GB14536.10:2008 IEC 60730-1:1999+A1:2003 IEC 60730:2000+A1+A2	CQC 10002046295
Alternative	Foshan Tianpeng Thermostat Co., Ltd.	T series	AC250V, 10A or 16A, Tf170 or Tf180, T250, 3E4	GB14536.1:2008 GB14536.10:2008 IEC 60730-1:1999+A1:2003 IEC 60730:2000+A1+A2	CQC 03002007756
Thermal cut-out for models not more than 3250W	Foshan Shunde Xingtang Zhongbao Thermostat Co., Ltd.	KSD301- Cy	AC250V, 15A or 16A, T270, Tf170 or Tf180, Cycle 35000	EN 60730-1:2011 EN 60730-2-9:2010 IEC 60730-1:2010 IEC 60730-2-9:2008	TUV R 50114187
Alternative	Foshan Tianpeng Thermostat Co., Ltd.	T1/33	AC250V, 16A, Tf170 or Tf180, T210, 1E4	EN 60730-1:2011 EN 60730-2-9:2010 IEC 60730-1:2010 IEC 60730-2-9:2008	TUV Rh R50091107
Alternative	Foshan Tianpeng Thermostat Co., Ltd.	T1/33 series	AC250V, 16A, T210, Tf170 or Tf180, 3E4	EN 60730-1:2011 EN 60730-2-9:2010 IEC 60730-1:2010 IEC 60730-2-9:2008	VDE 40019583
Alternative	Zhongshan Huilong Electrical Co., Ltd.	KSD301G	AC250V, 16A, Tf170 or Tf180, T300, 6E4	EN 60730-1:2011 EN 60730-2-9:2010 IEC 60730-1:2010 IEC 60730-2-9:2008	VDE 40034938
Thermal cut-out for models not more than 3250W, not for CE, GS	Zhongshan Huilong Electrical Co., Ltd.	KSD301G	AC250V, 16A, Tf170 or Tf180, T300, 6E4	GB14536.1:2008 GB14536.10:2008 IEC 60730-1:1999+A1:2003 IEC 60730:2000+A1+A2	CQC 10002046295

IEC 60335-2-15					
Clause	Requirement + Test			Result - Remark	Verdict
Alternative	Foshan Tianpeng Thermostat Co., Ltd.	T series	AC250V, 16A, Tf170 or Tf180, T250, 3E4	GB14536.1:2008 GB14536.10:2008 IEC 60730-1:1999+A1:2003 IEC 60730:2000+A1+A2	CQC 03002007756
Thermal cut-out for models not more than 3500W	Foshan Shunde Xingtian Zhongbao Thermostat Co., Ltd.	KSD301- cy	AC250V, 16A, T270, Tf170 or Tf180, 1E4	EN 60730-1:2011 EN 60730-2-9:2010 IEC 60730-1:2010 IEC 60730-2-9:2008	TUV R 50114187
Alternative	Foshan Tianpeng Thermostat Co., Ltd.	T1/33	AC250V, 16A, Tf170 or Tf180, T210, 1E4	EN 60730-1:2011 EN 60730-2-9:2010 IEC 60730-1:2010 IEC 60730-2-9:2008	TUV Rh R50091107
Alternative	Foshan Tianpeng Thermostat Co., Ltd.	T1/33 series	AC250V, 16A, T210, Tf170 or Tf180, 3E4	EN 60730-1:2011 EN 60730-2-9:2010 IEC 60730-1:2010 IEC 60730-2-9:2008	VDE 40019583
Alternative	Zhongshan Huilong Electrical Co., Ltd.	KSD301G	AC250V, 16A, Tf170 or Tf180, T300, 6E4	EN 60730-1:2011 EN 60730-2-9:2010 IEC 60730-1:2010 IEC 60730-2-9:2008	VDE 40034938
Thermal cut-out for models not more than 3500W, Not for CE, GS)	Zhongshan Huilong Electrical Co., Ltd.	KSD301G	AC250V, 10A/16A, Tf170 or Tf180, T300, 6E4	GB14536.1:2008 GB14536.10:2008 IEC 60730-1:1999+A1:2003 IEC 60730:2000+A1+A2	CQC 10002046295
Alternative	Foshan Tianpeng Thermostat Co., Ltd.	T series	AC250V, 16A, Tf170 or Tf180, T250, 3E4	GB14536.1:2008 GB14536.10:2008 IEC 60730-1:1999+A1:2003 IEC 60730:2000+A1+A2	CQC 03002007756
Micro-switch (Not for models more than 1000W in RC series)	Dong Nan Electronics Co., Ltd.	KW3AT-16	AC250V, 16A, T125, 1E4	EN 61058-1 :2002+A2 :2008 IEC 61058-1:2000+A1 :2001+A2 :2007	VDE 40011294
Alternative	Yueqing Tongda Wire Electric Factory.	HK-14	AC250V, 16A, T125, 5E4	EN 61058-1 :2002+A2 :2008 IEC 61058-1:2000+A1 :2001+A2 :2007	VDE 40027032
Alternative	Foshan Shunde Hushun Electric Appliance Co., Ltd	LXW-16-1-3, LXW-16-2-3, LXW-16-3-3	AC 250V, 16A, T125, 3E4	EN 61058-1 :2002+A2 :2008 IEC 61058-1:2000+A1 :2001+A2 :2007	TUV Rh R 50156816

IEC 60335-2-15					
Clause	Requirement + Test		Result - Remark		Verdict
Alternative	Guangzhou Taiheng Electric Appliance Co., Ltd.	THW-16	AC250V, 16A, T120, 5E4	EN 61058-1 :2002+A2 :2008 IEC 61058-1:2000+A1 :2001+A2 :2007	TUV Rh R 50200051
Alternative	Foshan Shunde Shunshen Electric Appliance Ltd	LXW-16	AC250V, 16A, T125, 3E4	EN 61058-1 :2002+A2 :2008 IEC 61058-1:2000+A1 :2001+A2 :2007	TUV Rh R 50214883
Alternative	Foshang Shunde Shuda Electric Appliance Co., Ltd	KW-16	AC250V, 16A, T125, 3E4	EN 61058-1 :2002+A2 :2008 IEC 61058-1:2000+A1 :2001+A2 :2007	TUV Rh R 50359264
Micro-switch (Not for models more than 1000W in RC series, Not for CE, GS)	Yueqing Tongda Wire Electric Factory.	HK-14	AC250V, 16A, T125, 5E4	GB15092.1-2010 IEC 61058-1:2000+A1+A2	CQC 09002029212
Alternative	Dong Nan Electronics Co., Ltd.	KW3AT-16	AC250V, 16A, T125, 1E4	GB15092.1-2010 IEC 61058-1:2000+A1+A2	CQC 04002011512
Alternative	Guangzhou Taiheng Electric Appliance Co., Ltd	THW-16	AC250V, 16A, T120, 1E4	GB15092.1-2010 IEC 61058-1:2000+A1+A2	CQC 03002004096
Alternative	Foshang Shunde Shuda Electric Appliance Co., Ltd	KW-16	AC250V, 16A, T125, 3E4	GB15092.1-2010 IEC 61058-1:2000+A1+A2	CQC 16002152789
Alternative	Foshan Shunde Shunshen Co., Ltd	LXW-16	AC250V, 16A, T125, 3E4	GB15092.1-2010 IEC 61058-1:2000+A1+A2	CQC 11002063640
Switch linked to magnetic temperature limiter (for models not more than 2200W)	Zhanjiang Gaobo Electrical Appliance Co., Ltd	--	AC250V, 10A	IEC/EN 60335-1 IEC/EN 60335-2-15	Tested with appliance
Switch linked to magnetic temperature limiter	Zhanjiang Gaobo Electrical Appliance Co., Ltd	--	AC250V, 16A	IEC/EN 60335-1 IEC/EN 60335-2-15	Tested with appliance
Power switch (for models not more than 2200W) (Only for CE, GS)	Guangzhou Taiheng Electric Appliance Co., Ltd	TH1, TH2, TH3	AC250V, 15A, 1E4, T85	EN 61058-1 :2002+A2 :2008 IEC 61058-1:2000+A1 :2001+A2 :2007	TUV Rh R50150473

IEC 60335-2-15					
Clause	Requirement + Test			Result - Remark	Verdict
Alternative	NINGBO YINXIAN LIHE SWITCH FACTORY	RL3 series	AC250V, 10A, 1E4, T85 or T125	EN 61058-1 :2002+ A2 :2008 IEC 61058-1: 2000+A1 :2001+A2 : 2007	ENEC SE/09127-14
Alternative	NINGBO YINXIAN LIHE SWITCH FACTORY	RL2, RL2F	AC250V, 16A, 1E4, T125	EN 61058-1 :2002+ A2 :2008 IEC 61058-1: 2000+A1 :2001+A2 : 2007	ENEC SE/09127-06
Alternative	NINGBO YINXIAN LIHE SWITCH FACTORY	RL2	AC250V, 16A, 1E4, T85	EN 61058-1 :2002+ A2 :2008 IEC 61058-1: 2000+A1 :2001+A2 : 2007	ENEC SE/09127-06
Alternative	Guangzhou Bevan Electric Appliance Co., Ltd	BR12, BR13	AC250V, 12A, 1E4, T120	EN 61058-1 :2002+ A2 :2008 IEC 61058-1: 2000+A1 :2001+A2 : 2007	TUV Rh R50355895
Alternative	Guangzhou Bevan Electric Appliance Co., Ltd	BR23	AC250V, 16A, 1E4, T120	EN 61058-1 :2002+ A2 :2008 IEC 61058-1: 2000+A1 :2001+A2 : 2007	TUV Rh R50355897
Alternative	YUEQING YANHUI ELECTRONIC CO.,LTD	PS8A, PS8C	AC250V, 16A/12A, 10E3, T105	EN 61058-1 :2002+ A2 :2008 IEC 61058-1: 2000+A1 :2001+A2 : 2007	VDE 40027141
Alternative	YUEQING QIYANG ELECTRONICS CO.,LTD	QY604-201N	AC250V, 15A, 1E4, T125	EN 61058-1 :2002+ A2 :2008 IEC 61058-1: 2000+A1 :2001+A2 : 2007	TUV B170298459
Alternative	Yueqing Tongda Wire Electric Factory.	GQ121	AC250V 10A 10E3 T85	EN 61058-1 :2002+ A2 :2008 IEC 61058-1: 2000+A1 :2001+A2 : 2007	VDE 40026153
Alternative	Jackson Electronics Ind. Corp.	JS-608-F, JS-608-R	AC250V, 16A, 10E3, T85	EN 61058-1 :2002+ A2 :2008 IEC 61058-1: 2000+A1 :2001+A2 : 2007	VDE 40003763
Power switch (for models not more than 3250W) (Only for CE, GS)	Guangzhou Taiheng Electric Appliance Co., Ltd	TH1, TH2, TH3	AC250V, 15A, 1E4, T85	EN 61058-1 :2002+ A2 :2008 IEC 61058-1: 2000+A1 :2001+A2 : 2007	TUV Rh R50150473

IEC 60335-2-15					
Clause	Requirement + Test			Result - Remark	Verdict
Alternative	NINGBO YINXIAN LIHE SWITCH FACTORY	RL2, RL2F	AC250V, 16A, 1E4, T125	EN 61058-1 :2002+A2 :2008 IEC 61058-1: 2000+A1 :2001+A2 : 2007	ENEC SE/09127-06
Alternative	NINGBO YINXIAN LIHE SWITCH FACTORY	RL2	AC250V, 16A, 1E4, T85	EN 61058-1 :2002+A2 :2008 IEC 61058-1: 2000+A1 :2001+A2 : 2007	ENEC SE/09127-06
Alternative	YUEQING QIYANG ELECTRONICS CO., LTD	QY604-201N	AC250V, 15A, 1E4, T125	EN 61058-1 :2002+A2 :2008 IEC 61058-1: 2000+A1 :2001+A2 : 2007	TUV B170298459
Alternative	Guangzhou Bevan Electric Appliance Co., Ltd	BR23	AC250V, 16A, 1E4, T120	EN 61058-1 :2002+A2 :2008 IEC 61058-1: 2000+A1 :2001+A2 : 2007	TUV Rh R50355897
Alternative	Jackson Electronics Ind. Corp.	JS-608-F, JS-608-R	AC250V, 16A, 10E3, T85	EN 61058-1 :2002+A2 :2008 IEC 61058-1: 2000+A1 :2001+A2 : 2007	VDE 40003763
Power switch (for models not more than 3500W) (Only for CE, GS)	NINGBO YINXIAN LIHE SWITCH FACTORY	RL2, RL2F	AC250V, 16A, 1E4, T125	EN 61058-1 :2002+A2 :2008 IEC 61058-1: 2000+A1 :2001+A2 : 2007	ENEC SE/09127-06
Alternative	NINGBO YINXIAN LIHE SWITCH FACTORY	RL2	AC250V, 16A, 1E4, T85	EN 61058-1 :2002+A2 :2008 IEC 61058-1: 2000+A1 :2001+A2 : 2007	ENEC SE/09127-06
Alternative	Guangzhou Bevan Electric Appliance Co., Ltd	BR23	AC250V, 16A, 1E4, T120	EN 61058-1 :2002+A2 :2008 IEC 61058-1: 2000+A1 :2001+A2 : 2007	TUV Rh R50355897
Alternative	YUEQING QIYANG ELECTRONICS CO.,LTD	QY604-201N	AC250V, 30A, 1E4, T125	EN 61058-1 :2002+A2 :2008 IEC 61058-1: 2000+A1 :2001+A2 : 2007	TUV B170298459
Alternative	Jackson Electronics Ind. Corp.	JS-608-F, JS-608-R	AC250V, 16A, 10E3, T85	EN 61058-1 :2002+A2 :2008 IEC 61058-1: 2000+A1 :2001+A2 : 2007	VDE 40003763

IEC 60335-2-15					
Clause	Requirement + Test			Result - Remark	Verdict
Magnetic temperature limiter (for model RC03-y)	Xinyi Jiandong Electronic Co., Ltd	--	Tf135°C	IEC/EN 60335-1 IEC/EN 60335-2-15	Tested with appliance
Alternative	Xinyi Fuer Electronic Co., Ltd	--	Tf135°C	IEC/EN 60335-1 IEC/EN 60335-2-15	Tested with appliance
Alternative	Xinyi Huayu Electronics Technology Co., Ltd	--	Tf135°C	IEC/EN 60335-1 IEC/EN 60335-2-15	Tested with appliance
Magnetic temperature limiter (for models 300W 550W)	Xinyi Jiandong Electronic Co., Ltd	--	Tf145°C or Tf155°C	IEC/EN 60335-1 IEC/EN 60335-2-15	Tested with appliance
Alternative	Xinyi Fuer Electronic Co., Ltd	--	Tf145°C or Tf155°C	IEC/EN 60335-1 IEC/EN 60335-2-15	Tested with appliance
Alternative	Xinyi Huayu Electronics Technology Co., Ltd	--	Tf145°C or Tf155°C	IEC/EN 60335-1 IEC/EN 60335-2-15	Tested with appliance
Magnetic temperature limiter (for models 600W to 1300W)	Xinyi Jiandong Electronic Co., Ltd	--	Tf155°C or Tf157°C or Tf160°C	IEC/EN 60335-1 IEC/EN 60335-2-15	Tested with appliance
Alternative	Xinyi Fuer Electronic Co., Ltd	--	Tf155°C or Tf157°C or Tf160°C	IEC/EN 60335-1 IEC/EN 60335-2-15	Tested with appliance
Alternative	Xinyi Huayu Electronics Technology Co., Ltd	--	Tf155°C or Tf157°C or Tf160°C	IEC/EN 60335-1 IEC/EN 60335-2-15	Tested with appliance
Magnetic temperature limiter (for models more than 1300W)	Xinyi Jiandong Electronic Co., Ltd	--	Tf157°C or Tf160°C	IEC/EN 60335-1 IEC/EN 60335-2-15	Tested with appliance
Alternative	Xinyi Fuer Electronic Co., Ltd	--	Tf157°C or Tf160°C	IEC/EN 60335-1 IEC/EN 60335-2-15	Tested with appliance
Alternative	Xinyi Huayu Electronics Technology Co., Ltd	--	Tf157°C or Tf160°C	IEC/EN 60335-1 IEC/EN 60335-2-15	Tested with appliance

IEC 60335-2-15					
Clause	Requirement + Test			Result - Remark	Verdict
Heating Element	Lianjiang Huafu Electrical Appliance Co., Ltd	--	AC 220-240V, 220W, 300W, 350W, 400W, 450W, 500W, 550W, 600W, 650W, 700W, 750W, 850W, 900W, 950W, 1000W, 1100W, 1200W, 1250W, 1300W, 1550W, 1600W, 1950W, 2000W, 2200W, 2250W, 2500W, 2650W, 2800W, 3000W, 3200W, 3250W, 3500W	IEC/EN 60335-1 IEC/EN 60335-2-15	Tested with appliance
Keep warm heater (not for RC03-y; not for models more than 1000W in RC series)	Lianjiang Mingfung Insulation Plate Factory	---	AC 220-240V, 50/60Hz, 40W or 45W	IEC/EN 60335-1 IEC/EN 60335-2-15	Tested with appliance
Internal Wire	Nizing Electric Co., Ltd.	3122	24AWG-16AWG, T200, 300V	IEC/EN 60335-1 IEC/EN 60335-2-15	Tested with appliance / UL E215834
Alternative	Shenzhen Woer Heat-shrinkable Material Co., Ltd.	3122	24AWG-16AWG, T200, 300V	IEC/EN 60335-1 IEC/EN 60335-2-15	Tested with appliance / UL E227566
Alternative	Qifurui Electronics Co., Ltd.	3122	24AWG-16AWG, T200, 300V	IEC/EN 60335-1 IEC/EN 60335-2-15	Tested with appliance / UL E211048
Alternative	ZHUHAI HENGWANG ELECTRONICS CO., LTD	3122	24AWG-16AWG, T200, 300V	IEC/EN 60335-1 IEC/EN 60335-2-15	Tested with appliance / UL E314186
Alternative	CIXI SHUANGHONG WIRE Co., Ltd.	3122	24AWG-16AWG, T200, 300V	IEC/EN 60335-1 IEC/EN 60335-2-15	Tested with appliance / UL E333296
Alternative	CIXI SHUANGHONG WIRE CO., LTD.	H05S-K , H05SJ-K	0,5-2,5mm ² , T180	IEC/EN 60335-1 IEC/EN 60335-2-15	Tested with appliance VDE 40017324

IEC 60335-2-15					
Clause	Requirement + Test			Result - Remark	Verdict
Alternative	Qifurui Electronics Co., Ltd.	N5GFAF	0,5-2,5mm ² , T180	IEC/EN 60335-1 IEC/EN 60335-2-15	Tested with appliance VDE 134824
Alternative	ZHUHAI HENGWANG ELECTRONICS CO., LTD	H05S-K; H05SJ-K	0,5-2,5mm ² , T180	IEC/EN 60335-1 IEC/EN 60335-2-15	Tested with appliance VDE 40025629
Alternative	Qifurui Electronics Co., Ltd.	60245 IEC 03	0,5-2,5mm ² , 300/500V 180°C	IEC/EN 60335-1 IEC/EN 60335-2-15	Tested with appliance / CCC 20020101040 00754
Alternative	Zhongshan Sanjin Electronics Co., Ltd.	60245 IEC 03	0,5-2,5mm ² , 300/500V 180°C	IEC/EN 60335-1 IEC/EN 60335-2-15	Tested with appliance / CCC 20130101046 33878
Alternative	ZHONGSHAN DINGXIN INSULATION MATERIALS FACTORY.	60245 IEC 03	0,5-2,5mm ² , 300/500V 180°C	IEC/EN 60335-1 IEC/EN 60335-2-15	Tested with appliance / CCC 20140101047 05971
Alternative	CIXI SHUANGHONG WIRE Co., Ltd.	60245 IEC 03	0,5-2,5mm ² , 300/500V 180°C	IEC/EN 60335-1 IEC/EN 60335-2-15	Tested with appliance / CCC 20090101043 61398
Silicone fibreglass Sleeving	Anji Hengtai Insulation Material Co., Ltd.	2753	T200, 600V	IEC/EN 60335-1 IEC/EN 60335-2-15	Tested with appliance / UL E220238
Alternative	Guangdong Shunde Beijiao Hongqiao Insulation Material Factory	CSEEUL001	T200, 600V	IEC/EN 60335-1 IEC/EN 60335-2-15	Tested with appliance / UL E154902
Heat-shrinkage tube	Guangzhou Kaiheng Enterprise Group	K-2(+)	T125, 600V, VW-1	IEC/EN 60335-1 IEC/EN 60335-2-15	Tested with appliance / UL E214175
Alternative	Dongguan Salipt Co., Ltd	SALIPT S-901-600	T125, 600V, VW-1	IEC/EN 60335-1 IEC/EN 60335-2-15	Tested with appliance / UL E209436
Alternative	Shenzhen Woer Heatshrinkable Material Co., Ltd.	RSFR-X	T125, 600V, VW-1	IEC/EN 60335-1 IEC/EN 60335-2-15	Tested with appliance / UL E203950
Alternative	EIB TRADING CO	IBTF2-600	T125, 600V, VW-1	IEC/EN 60335-1 IEC/EN 60335-2-15	Tested with appliance / UL E314381
Alternative	Qifurui Electronics Co., Ltd.	QFR-h	T125, 600V, VW-1	IEC/EN 60335-1 IEC/EN 60335-2-15	Tested with appliance / UL E225897
Plastic enclosure, Control panel	Guangdong Gaobo Electrical Appliance Co., Ltd.	---	ABS, HB	IEC/EN 60335-1 IEC/EN 60335-2-15	Tested with appliance

IEC 60335-2-15					
Clause	Requirement + Test			Result - Remark	Verdict
(Alternative)	LG Chemical (Guangzhou) Engineering Plastics Co., Ltd	HI121(#)	ABS, HB	IEC/EN 60335-1 IEC/EN 60335-2-15	Tested with appliance / UL E248280
(Alternative)	Guangdong Gaobo Electrical Appliance Co., Ltd.	---	PP, V-2	IEC/EN 60335-1 IEC/EN 60335-2-15	Tested with appliance
(Alternative)	LG Chemical (Guangzhou) Engineering Plastics Co., Ltd	LUPOL GP-1007F(#)	PP, V-2	IEC/EN 60335-1 IEC/EN 60335-2-15	Tested with appliance / UL E248280
Lamp cover	Teijin Polycarbonate China Ltd	L-1250	PC	IEC/EN 60335-1 IEC/EN 60335-2-15	Tested with appliance
(Alternative)	Guangdong Gaobo Electrical Appliance Co., Ltd.	---	PC	IEC/EN 60335-1 IEC/EN 60335-2-15	Tested with appliance
PCB	Nanmei Copper Clad Laminate Factory Ltd	NWFR-4	V-0, T130	IEC/EN 60335-1 IEC/EN 60335-2-15	Tested with appliance / UL E128450
(Alternative)	KINGBOARD LAMINATES LTD.	KB-6150	V-0, T130	IEC/EN 60335-1 IEC/EN 60335-2-15	Tested with appliance / UL E123995

IEC 60335-2-15			
Clause	Requirement + Test	Result - Remark	Verdict

28.1	TABLE: Threaded part torque test			P
Threaded part identification	Diameter of thread (mm)	Column number (I, II, or III)	Applied torque (Nm)	
Screws for earthing	3,8	II	1,2	
Screws for electric connection	3,8	II	1,2	
Supplementary information:				

29.1 - 29.2	TABLE: Clearance and creepage distance measurements						P
Clearance cl and creepage distance dcr at/of:	Up (V)	U r.m.s. (V)	Required cl (mm)	cl (mm)	Required dcr (mm)	dcr (mm)	
Live part and earthed metal	339,4	240 V	2,0	4,2	4,0	4,2	
Internal wire and accessible part	339,4	240 V	2,0	5,1	4,0	5,1	
L and N	339,4	240 V	2,0	3,3	3,2	3,3	
Live part and accessible plastic	339,4	240 V	3,5	12,3	8,0	15,6	
Supplementary information:							

29.3	TABLE: Distance through insulation measurements				P
Distance through insulation di at/of:	U r.m.s. (V)	Test voltage (V)	Required di (mm)	di (mm)	
Enclosure	240	240	1,0	1,4	
Control panel	240	240	1,0	1,4	
Supplementary information:					

30.1	TABLE: Ball pressure test of thermoplastics			P
Allowed impression diameter (mm)			2.0	—
Object/part No./material	Manufacturer/trademark	Test temperature (°C)	Impression diameter (mm)	
Plastic enclosure / control panel, model N/A, material: ABS	Guangdong Gaobo Electrical Appliance Co., Ltd.	102,2	1,2	
Plastic enclosure / control panel, model HI121(#), material: ABS	LG Chemical (Guangzhou) Engineering Plastics Co., Ltd	102,2	1,0	
Plastic enclosure / control panel, model N/A, material: PP	Guangdong Gaobo Electrical Appliance Co., Ltd.	102,2	1,1	
Plastic enclosure / control panel, model LUPOL GP-1007F(#), material: PP	LG Chemical (Guangzhou) Engineering Plastics Co., Ltd	102,2	0,8	

IEC 60335-2-15			
Clause	Requirement + Test	Result - Remark	Verdict
Lamp cover, model L-1250, material: PC	Teijin Polycarbonate China Ltd	94,8	0,6
Lamp cover, model N/A, material: PC	Guangdong Gaobo Electrical Appliance Co., Ltd.	94,8	0,8

Supplementary information:

30.2	TABLE: Resistance to heat and fire – Glow-wire tests							P
Object/part No./material	Manufacturer/trademark	Glow-wire test (GWT) (°C)						Verdict
		550	650		750		850	
			te	ti	te	ti		
Plastic enclosure / control panel, model N/A, material: ABS	Guangdong Gaobo Electrical Appliance Co., Ltd.	x	—	—	—	—	—	P
Plastic enclosure / control panel, model HI121(#), material: ABS	LG Chemical (Guangzhou) Engineering Plastics Co., Ltd	x	—	—	—	—	—	P
Plastic enclosure / control panel, model N/A, material: PP	Guangdong Gaobo Electrical Appliance Co., Ltd.	x	—	—	—	—	—	P
Plastic enclosure / control panel, model LUPOL GP-1007F(#), material: PP	LG Chemical (Guangzhou) Engineering Plastics Co., Ltd	x	—	—	—	—	—	P
Lamp cover, model L-1250, material: PC	Teijin Polycarbonate China Ltd		0 s	0 s	—	—	—	P
Lamp cover, model N/A, material: PC	Guangdong Gaobo Electrical Appliance Co., Ltd.		0 s	0 s	—	—	—	P
Inlet, model HF-301	Zhang Jia Gang Hua Feng Electronic Connector & Component Co., Ltd.	—	—	—	0 s	0 s	X	P
Inlet, model 2107	Steady Electronics Corporation	—	—	—	0 s	0 s	X	P
Inlet, model ST-A02	Zhe Jiang Bei Er Electronic Co., Ltd.	—	—	—	0 s	0 s	X	P
Inlet, model ST-A01	Zhe Jiang Bei Er Electronic Co., Ltd.	—	—	—	0 s	0 s	X	P
Inlet, model JR-101	Jackson Electronics Ind. Corp.	—	—	—	0 s	0 s	X	P
Inlet, model DB-14	YUEQING YANHUI ELECTRONIC CO.,LTD	—	—	—	0 s	0 s	X	P
Inlet, model P-2	Guangdong Yincheng Electric Appliance Co., Ltd.	—	—	—	0 s	0 s	X	P
Inlet, model P-3A	Zhanjiang Yexing Electrical Appliance Co., Ltd	—	—	—	0 s	0 s	X	P

IEC 60335-2-15								
Clause	Requirement + Test	Result - Remark					Verdict	
Inlet, model P-3B	Zhanjiang Yexing Electrical Appliance Co., Ltd	—	—	—	0 s	0 s	X	P
Inlet, model YZ-01	LIANJIANG CITY YANGZHOU ELECTRICAL APPLIANCE FACTORY	—	—	—	0 s	0 s	X	P
Inlet, model HX	Lianjiang HUAXI Electrical Appliance Factory	—	—	—	0 s	0 s	X	P
Micro Switch, model KW3AT-16	Yueqing Dong Nan Electronic Co.	—	—	—	0 s	0 s	X	P
Micro Switch, model HK-14	Yueqing Tongda Wire Electric Factory.	—	—	—	0 s	0 s	X	P
Micro Switch, model LXW-16-1-3	Foshan Shunde Hushun Electric Appliance Co., Ltd	—	—	—	0 s	0 s	X	P
Micro Switch, model LXW-16-2-3	Foshan Shunde Hushun Electric Appliance Co., Ltd	—	—	—	0 s	0 s	X	P
Micro Switch, model LXW-16-3-3	Foshan Shunde Hushun Electric Appliance Co., Ltd	—	—	—	0 s	0 s	X	P
Micro Switch, model THW-16	Guangzhou Taiheng Electric Appliance Co., Ltd.	—	—	—	0 s	0 s	X	P
Micro Switch, model LXW-16	Foshan Shunde Shunshen Electric Appliance Ltd	—	—	—	0 s	0 s	X	P
Power switch, model TH1	Guangzhou Taiheng Electric Appliance Co., Ltd	—	—	—	0 s	0 s	X	P
Power switch, model TH2	Guangzhou Taiheng Electric Appliance Co., Ltd	—	—	—	0 s	0 s	X	P
Power switch, model TH3	Guangzhou Taiheng Electric Appliance Co., Ltd	—	—	—	0 s	0 s	X	P
Power switch, model RL3	NINGBO YINXIAN LIHE SWITCH FACTORY	—	—	—	0 s	0 s	X	P
Power switch, model RL2	NINGBO YINXIAN LIHE SWITCH FACTORY	—	—	—	0 s	0 s	X	P
Power switch, model RL2F	NINGBO YINXIAN LIHE SWITCH FACTORY	—	—	—	0 s	0 s	X	P
Power switch, model BR12	Guangzhou Bevan Electric Appliance Co., Ltd	—	—	—	0 s	0 s	X	P
Power switch, model BR13	Guangzhou Bevan Electric Appliance Co., Ltd	—	—	—	0 s	0 s	X	P
Power switch, model BR23	Guangzhou Bevan Electric Appliance Co., Ltd	—	—	—	0 s	0 s	X	P

IEC 60335-2-15									
Clause	Requirement + Test	Result - Remark						Verdict	
Power switch, model PS8A	YUEQING YANHUI ELECTRONIC CO.,LTD	—	—	—	0 s	0 s	X	P	
Power switch, model PS8C	YUEQING YANHUI ELECTRONIC CO.,LTD	—	—	—	0 s	0 s	X	P	
Power switch, model QY604-201N	YUEQING QIYANG ELECTRONICS CO.,LTD	—	—	—	0 s	0 s	X	P	
Power switch, model GQ121	Yueqing Tongda Wire Electric Factory.	—	—	—	0 s	0 s	X	P	
Power switch, model JS-608-F	Jackson Electronics Ind. Corp.	—	—	—	0 s	0 s	X	P	
Power switch, model JS-608-R	Jackson Electronics Ind. Corp.	—	—	—	0 s	0 s	X	P	
Silicone fibreglass Sleeving, model 2753	Anji Hengtai Insulation Material Co., Ltd.	—	—	—	0 s	0 s	X	P	
Silicone fibreglass Sleeving, model CSEEUL001	Guangdong Shunde Beijiao Hongqiao Insulation Material Factory	—	—	—	0 s	0 s	X	P	
Heat-shrinkage tube, model K-2(+)	Guangzhou Kaiheng Enterprise Group	—	—	—	0 s	0 s	X	P	
Heat-shrinkage tube, model SALIPT S-901-600	Dongguan Salipt Co., Ltd	—	—	—	0 s	0 s	X	P	
Heat-shrinkage tube, model RSFR-X	Shenzhen Woer Heatshrinkable Material Co., Ltd.	—	—	—	0 s	0 s	X	P	
Heat-shrinkage tube, model IBTF2-600	EIB TRADING CO	—	—	—	0 s	0 s	X	P	
Heat-shrinkage tube, model QFR-h	Qifurui Electronics Co., Ltd.	—	—	—	0 s	0 s	X	P	
Object/part No./material	Manufacturer/trademark	Glow-wire flammability index (GWFI) (°C)				GW ignition temp. (GWIT) (°C)		Verdict	
		550	650	750	850	675	775		
The test specimen passed the glow-wire test (GWT) with no ignition [(te – ti) ≤ 2 s] (Yes/No)... :								Yes	
If no, then surrounding parts passed the needle-flame test of Annex E (Yes/No)								N/A	
The test specimen passed the test by virtue of most of the flaming material being withdrawn with the glow-wire (Yes/No)?.....								Yes	
Ignition of the specified layer placed underneath the test specimen (Yes/No).....								No	
Supplementary information:									
550 °C GWT not relevant (or applicable) to parts of material classified at least HB40 or if relevant HBF. The GWIT pre-selection option, the 850 °C GWFI pre-selection option, and the 850 °C GWT are not relevant (or applicable) for attended appliances.									

IEC 60335-2-15			
Clause	Requirement + Test	Result - Remark	Verdict

30.2/30.2.4 TABLE: Needle-flame test (NFT)					P
Object/part No./material	Manufacturer/trademark	Duration of application of test flame (ta) (s)	Ignition of specified layer Yes/No	Duration of burning (tb) (s)	Verdict
PCB	Nanmei Copper Clad Laminate Factory Ltd	30 s	Yes	0	P
PCB	KINGBOARD LAMINATES LTD.	30 s	Yes	0	P
Supplementary information: NFT not relevant (or applicable) for parts of material classified as V-0 or V-1. NFT not relevant (or applicable) for base material of PCBs classified as V-0 or if relevant VTM-0.					

--End of report --



Attachment 1

IEC60335_2_150 ATTACHMENT			
Clause	Requirement + Test	Result - Remark	Verdict

ATTACHMENT TO TEST REPORT IEC 60335-2-15 EUROPEAN GROUP DIFFERENCES AND NATIONAL DIFFERENCES Household and similar electrical appliances – Safety – Part 2: Particular requirements for appliances for heating liquids	
Differences according to.....:	EN 60335-2-15:2016 used in conjunction with EN 60335-1:2012 + AC:2014 + A11:2014 + A12:2017 EN 62233:2008
Attachment Form No.....:	EU_GD_IEC60335_2_150
Attachment Originator.....:	IMQ S.p.A.
Master Attachment.....:	2017-09
Copyright © 2017 IEC System of Conformity Assessment Schemes for Electrotechnical Equipment and Components (IECEE System). All rights reserved.	

	CENELEC COMMON MODIFICATIONS		--
6.1	Delete "class 0" and "class 0I"		P
7.1	Single-phase appliances to be connected to the supply mains: 230 V covered		P
	Multi-phase appliances to be connected to the supply mains: 400 V covered		N/A
	When the provisions of footnote ^b to Table Z101 apply, the appliance shall be marked with: (EN 60335-2-15)		--
	- the substance of "CAUTION: Hot surface", or		N/A
	- symbol IEC 60417-5041		N/A
	The warning shall be put on the surface of the appliance having the highest temperature (EN 60335-2-15)		N/A
	and shall be visible during normal use (EN 60335-2-15)		N/A
7.6	[symbol IEC 60417-5041] Caution, hot surface (EN 60335-2-15)		N/A
7.10	The accessible switch required by 22.40 shall be distinguished from other manual devices by means of shape, or size, or surface texture, or position, etc. (EN 60335-2-15)		P
	An indication that the device has been operated shall be given by: (EN 60335-2-15)		--
	<ul style="list-style-type: none"> a tactile feedback, or 		P
	<ul style="list-style-type: none"> an audible and visual feedback. 		N/A
	A selector switch with an off-position clearly identifiable is allowed (EN 60335-2-15)		N/A
	An ON/OFF switch, if any, is considered a suitable device to stop operational functions. A plug is not considered a suitable device to stop operational functions, as it can be difficult to be reached by vulnerable persons (EN 60335-2-15)		P
7.12	The instructions for pressure cookers, glue pots with a water jacket, livestock feed boilers, sterilizers, soy milk makers, wash boilers shall include the substance of the following: (EN 60335-2-15)		--
	- This appliance shall not be used by children. Keep the appliance and its cord out of reach of children		N/A
	The instructions for cooking pans, slow cookers, steam cookers, rice cookers, coffee-makers, kettles, egg boilers, milk heaters, tea makers shall include the substance of the following: (EN 60335-2-15)		--
	- This appliance can be used by children aged from 8 years and above if they have been given supervision or instruction concerning use of the appliance in a safe way and if they understand the hazards involved. Cleaning and user maintenance shall not be made by children unless they are older than 8 and supervised. Keep the appliance and its cord out of reach of children aged less than 8 years		P

	The instructions for feeding bottle heaters, yoghurt makers shall include the substance of the following: (EN 60335-2-15)		--
	- This appliance can be used by children aged from 3 years and above if they have been given supervision or instruction concerning use of the appliance in a safe way and understand the hazards involved. Cleaning and user maintenance shall not be made by children unless they are aged from 8 years and above and supervised. Keep the appliance and its cord out of reach of children aged less than 3 years		N/A
	The instructions shall also include the substance of the following: (EN 60335-2-15)		--
	- Appliances can be used by persons with reduced physical, sensory or mental capabilities or lack of experience and knowledge if they have been given supervision or instruction concerning use of the appliance in a safe way and understand the hazards involved		P
	- Children shall not play with the appliance		P
	If symbol IEC 60417-5041 is marked on the appliance, the instructions shall state that surfaces are liable to get hot during use (EN 60335-2-15)		N/A
7.12.Z1	The specific instructions related to the safe operation of this appliance is collated together in the front section of the user instructions		P
	The height of the characters, measured on the capital letters, is at least 3 mm		P
	These instructions are also available in an alternative format, e.g. on a website.....:		P
7.14	The height of symbol IEC 60417-5041 shall be at least 8 mm (EN 60335-2-15)		N/A
	The height of the warning "CAUTION. Hot surface" shall be at least 4 mm (measured on the capital letters) (EN 60335-2-15)		N/A
8.1.1	Also test probe 18 of EN 61032 is applied		--
	The appliance being in every possible position during the test, except that		P
	appliances normally used on the floor and having a mass exceeding 40 kg are not tilted		P
	The force on the probe in the straight position is increased to 10 N when probe 18 is used		P
	When using test probe 18 the appliance is fully assembled as in normal use without any parts removed, and		P
	parts intended to be removed for user maintenance are also not removed		P
8.2	Compliance is checked by applying the test probes of EN 61032		P

	For built-in appliances and fixed appliances, the test probe B and probe 18 of EN 61032 are applied only after installation		N/A
11.Z101	For coffee makers, milk heaters, egg boilers, cooking pans, slow cookers, steam cookers, pressure cookers, wash boilers, rice cookers, glue pots with a water jacket, livestock feed boilers, sterilizers, soy milk makers, tea makers, kettles and other appliances for boiling water, having a rated capacity not exceeding 10 l, the temperature rise limits in Table Z101 apply: (EN 60335-2-15)	(see appended table)	P
	The appliance is supplied at rated voltage and operated under normal operation (EN 60335-2-15)		P
	Temperature rises are not measured on: (60335-2-15)		--
	– the lids,		P
	– surfaces within 25 mm from <ul style="list-style-type: none"> • the edge of the lid, • the ventilation openings, • the edge of the hot functional surface 		P
	– enclosure at a distance within 25 mm from the heating element		P
	– underside surfaces that are not accessible with probe 41 of EN 61032. The probe is applied without appreciable force		P
11.Z102	For feeding-bottle heaters and yoghurt makers the temperature rise limits in Table Z101 apply: (EN 60335-2-15)		N/A
	The appliance is supplied at rated voltage and operated under normal operation (EN 60335-2-15)		N/A
15.1.2	Appliances with an automatic cord reel tested with the cord in the most unfavourable position so that the reeling of the wet cord may affect electrical insulation during operation, the cord not being dried before reeling		N/A
20.2	When using the test probe similar to test probe B with a circular stop face, the accessories and detachable covers are removed		N/A
	Test probe 18 applied with a force of 2,5 N on the appliance fully assembled		N/A
22.40	Appliances except eggs boilers, feeding bottle heaters, yogurt makers and slow cookers shall be fitted with an accessible switch or other means to stop operational functions of the appliance (EN 60335-2-15)		P
24.1	Components comply with the safety requirements specified in the relevant standards as far as they reasonably apply		P

	The requirements of Clause 29 of this standard apply between live parts of components and accessible parts of the appliance		P
	The requirements of 30.2 of this standard apply to parts of non-metallic material in components including parts of non-metallic material supporting current-carrying connections inside components		P
	Components that have not been previously tested or do not comply with the standard for the relevant component are tested according to the requirements of 30.2		P
	Components that have been previously tested and shown to comply with the resistance to fire requirements in the standard for the relevant component need not be retested provided that:		--
	- the severity specified in the component standard is not less than the severity specified in 30.2, and		P
	- the test report for the component states whether it complied with the standard for the relevant component with or without flame, flames not exceeding 2 s during the test are ignored		N/A
	Unless components have been previously tested and found to comply with the relevant standard for the number of cycles specified, they are tested in accordance with 24.1.1 to 24.1.9		P
	For components mentioned in 24.1.1 to 24.1.9, no additional tests specified in the relevant standard for the component are necessary other than those specified in 24.1.1 to 24.1.9		P
	Components that have not been separately tested and found to comply with the relevant standard, and		P
	components that are not marked or not used in accordance with their marking,		P
	are tested in accordance with the conditions occurring in the appliance, the number of samples being that required by the relevant standard		P
	Lamp holders and starter holders that have not been previously tested and found to comply with the relevant standard are tested as a part of the appliance and additionally comply with the gauging and interchangeability requirements of the relevant standard under the conditions occurring in the appliance		N/A
	Where the relevant standard specifies these gauging and interchangeability requirements at elevated temperatures, the temperatures measured during the tests of Clause 11 are used		N/A
	Plugs and socket-outlets and other connecting devices of interconnection cords are not interchangeable with plugs and socket-outlets listed in IEC/TR 60083 or IEC 60906-1, or		N/A

	with connectors and appliance inlets complying with the standard sheets of IEC 60320-1,		N/A
	if direct supply to these parts from the supply mains gives rise to a hazard		N/A
24.1.7	If the remote operation of the appliance is via a telecommunication network, the relevant standard for the telecommunication interface circuitry in the appliance is EN 41003		N/A
	Compliance with clause 8 of this standard is not impaired by connecting the appliance to a device covered by EN 41003		N/A
24.Z1	For motor running capacitors (IEC 60252-1 type S2 or S3) with a metallic enclosure having an overpressure fuse the flame testing of internal plastic parts supporting current carrying connections as required in 30.2.2 and 30.2.3.1 is not necessary		N/A
25.6	Supply cords of single-phase portable appliances having a rated current not exceeding 16 A, fitted with a plug complying with the following standard sheets of IEC/TR 60083:		--
	- for class I appliances: standard sheet C2b, C3b or C4	C4	P
	- for class II appliances: standard sheet C5 or C6		N/A
25.7	Rubber sheathed cords (60245 IEC 53) are not suitable for appliances intended to be used outdoors or when they are liable to be exposed to significant amount of ultraviolet radiation		N/A
	Halogen-free thermoplastic compound sheathed supply cords have properties at least those of:		--
	<ul style="list-style-type: none"> halogen-free thermoplastic compound sheathed cords (H03Z1Z1H2-F or H03Z1Z1-F), for appliances having a mass not exceeding 3 kg 		N/A
	<ul style="list-style-type: none"> halogen-free thermoplastic compound sheathed cords (H05Z1Z1H2-F or H05Z1Z1-F), for other appliances 		N/A
	Cross-linked halogen-free compound sheathed supply cords have properties at least those of cross-linked halogen-free compound sheathed cords (H07ZZ-F)		N/A
26.11	Conductors connected by soldering are not considered to be positioned or fixed so that reliance is not placed upon the soldering alone to maintain them in position unless they are held in place near the terminals independently of the solder		P
29.3.Z1	Appliance constructed so that if there is a possibility of damaging the insulation during installation, the insulation withstands the scratch and penetration test of 21.2		N/A

32	Compliance regarding electromagnetic fields is checked according to EN 62233		N/A
Annex I, 19.1.101	The appliance is supplied at rated voltage and operated under normal operation with each of the fault conditions specified		N/A
	The duration of the test is as specified in 19.7		N/A

ZA	ANNEX ZA (NORMATIVE) SPECIAL NATIONAL CONDITIONS		--
	Norway		--
19.5	The test is also applicable to appliances intended to be permanently connected to fixed wiring		Not check
	Norway		--
22.2	The second paragraph of this sub-clause, dealing with single-phase, permanently connected class I appliances having heating elements, is not applicable due to the supply system		Not check
	All CENELEC countries		--
25.6 and 25.25	Information concerning National plug and socket-outlets is available from the CENELEC website. Normative national requirements concerning plug and socket-outlets are shown in the relevant National standard		P
	Ireland and United Kingdom		--
25.8	In the table, the lines for >10 A and ≤16 A are replaced by:		--
	> 10 and ≤ 13 1,25 (1,0) ^b		Not check
	> 13 and ≤ 16 1,5 (1,0) ^b		Not check
ZB	ANNEX ZB (INFORMATIVE) A-DEVIATIONS		--
	Ireland		--
25.6	These regulations apply to all plugs for domestic use at a voltage of not less than 200 V and in general allow only plugs complying with I.S. 401:1997, or equivalent, to be fitted to domestic appliances		Not check

	United Kingdom		--
25.6	These regulations apply to all plugs for domestic use at a voltage of not less than 200 V and in general allow only plugs to BS 1363 to be fitted to domestic appliances. It also allows plugs to BS 4573 and EN 50075 to be fitted to shavers and toothbrushes		Not check
ZC	ANNEX ZC (NORMATIVE) NORMATIVE REFERENCES TO INTERNATIONAL PUBLICATIONS WITH THEIR CORRESPONDING EUROPEAN PUBLICATIONS		--
	A list of referenced documents in this standard		P
ZD	ANNEX ZD (INFORMATIVE) IEC and CENELEC CODE DESIGNATIONS FOR FLEXIBLE CORDS		--
	A table with IEC and CENELEC code designations for flexible cords		P
ZE	ANNEX ZE (INFORMATIVE) SPECIFIC ADDITIONAL REQUIREMENTS FOR APPLIANCES AND MACHINES INTENDED FOR COMMERCIAL USE		--
7.1	Business name and full address of the manufacturer and, where applicable, his authorized representative..... :		N/A
	Model or type reference		N/A
	Serial number, if any		N/A
	Production year		N/A
	Designation of the appliance		N/A
7.12	Instructions provided with the appliance so that the appliance can be used safely		N/A
	The instructions contain at least the following information:		--
	- the business name and full address of the manufacturer and, where applicable, his authorized representative		N/A
	- model or type reference of the appliance as marked on the appliance itself, except for the serial number		N/A
	- the designation of the appliance together with its explanation in case it is given by a combination of letters and/or numbers		N/A
	- the general description of the appliance, when needed due to the complexity of the appliance		N/A
	- specific precautions if required during installation, operation, adjusting, user maintenance, cleaning, repairing or moving		N/A

	- when needed drawings, diagrams, descriptions and explanations necessary for the safe use and user maintenance of the appliance		N/A
	- the possible reasonably foreseeable misuse and, whenever relevant, a warning against the effects it may have on the safe use of the appliance		N/A
	The words "Original instructions" appear on the language version(s) verified by the manufacturer or by the authorized representative		N/A
	When a translation of the original instructions has been provided by a person introducing the appliance on the market; the meaning of the sentence "Translation of the original instructions" appear in the relevant instructions delivered with the appliance		N/A
	The instructions for maintenance/service to be done by specialized personnel, mandated by the manufacturer or the authorized representative may be supplied in only one Community language which the specialized personnel understand		N/A
	The instructions indicate the type and frequency of inspections and maintenance required for safe operation including the preventive maintenance measures		N/A
7.12.ZE1	If needed for specific appliances, the following information to be given:		--
	<ul style="list-style-type: none"> on use, transportation, assembly, dismantling when out of service, testing or foreseeable breakdowns, if these operations have consequences on stability of the appliance in order to avoid overturning, falling or uncontrolled movements of the appliance or of its component parts 		N/A
	<ul style="list-style-type: none"> on how to maintain adequate mechanical stability when in use, during transportation, assembly, dismantling, scrapping and any other action involving the appliance 		N/A
	<ul style="list-style-type: none"> on the protective measures to be taken by the user, including, where appropriate, the personal protective equipment to be provided 		N/A
	<ul style="list-style-type: none"> on the operating method to be followed in the event of accident or breakdown; if a blockage is likely to occur the operating method to safely unblock the appliance 		N/A
	<ul style="list-style-type: none"> on the specifications on the spare parts to be used, when these affect the health and safety of the operator 		N/A
	<ul style="list-style-type: none"> on airborne noise emissions, determined and declared in accordance with the relevant Part 2, which includes: 		--

	- the A-weighted emission sound pressure level at workstations, where this exceeds 70 dB(A)		N/A
	- where this level does not exceed 70 dB(A), this fact is indicated		N/A
	- the peak C-weighted instantaneous sound pressure value at workstations, where this exceeds 63 Pa (130 dB in relation to 20 µPa)		N/A
	- the A-weighted sound power level emitted by the machinery, where the A-weighted emission sound pressure level at workstations exceeds 80 dB(A).....		N/A
7.12.ZE2	The instructions includes a warning to disconnect the appliance from its power source during service and when replacing parts		N/A
	If the removal of the plug is foreseen, it is clearly indicated that the removal of the plug has to be such that an operator can check from any of the points to which he has access that the plug remains removed		N/A
	If this is not possible, due to the construction of the appliance or its installation, a disconnection with a locking system in the isolated position is provided		N/A
19.11.4.8	The appliance continues to operate, without causing any hazard to the user, from the same point in its operating cycle at which the voltage fluctuation occurred, or		N/A
	a manual operation is required to restart it		N/A
20.1	Appliances and their components and fittings have adequate mechanical stability during transportation, assembly, dismantling and any other action involving the appliance		N/A
20.2	Dangerous moving transmission parts safeguarded either by design or guards		N/A
	When guards are used, they are fixed guards, interlocking movable guards or protective devices		N/A
	Moving parts directly involved in the function of the appliance which cannot be made completely inaccessible fitted with:		--
	- fixed guards or interlocking movable guards preventing access to those sections of the parts that are not used in the work, and		N/A
	- adjustable guards restricting access to those sections of the moving parts where access is necessary		N/A
	Interlocking movable guards used where frequent access is required		N/A

21.1	Appliances and their components and fittings have adequate mechanical strength and is constructed to withstand such rough handling that may be expected in normal use, during transportation, assembly, dismantling, scrapping and any other action involving the appliance		N/A
22.ZE.1	For appliances provided with a seat, the seat gives adequate stability		N/A
	The distance between the seat and the control devices capable of being adapted to the operator		N/A
22.ZE.2	For appliances provided with separate devices for the start and the stop functions, the stop function is unambiguously identifiable and does always override the start function		N/A
	For appliances provided with one device performing the start and the stop function, the stop function is unambiguously identifiable and does always override the start function		N/A
22.ZE.3	Appliances designed in such a way that incorrect mounting is avoided, if this can lead to an unsafe situation		N/A
	If this is not possible, information on the correct mounting is given directly on the part and/or the enclosure		N/A
22.ZE.4	Where the weight, size or shape prevents appliances from being moved manually, they are fitted with attachments for lifting gear, or		N/A
	so designed that they can be fitted with such attachments, or		N/A
	be shaped in such a way that standard lifting gear can easily be used		N/A
	Appliances to be moved manually are constructed or equipped so that they can be moved easily and safely		N/A
22.ZE.5	The fixing systems of fixed guards which prevent access to dangerous moving transmission parts only removable with the use of tools		N/A
	If such guards have to be removed by the user for routine cleaning or maintenance their fixing systems remain attached to the fixed guards or to the machine after removal		N/A
	Where possible, guards are incapable of remaining in place without their fixings		N/A
	This does not apply if, after removal of the screws, or if the component is incorrectly repositioned, the appliance becomes inoperative		N/A
	Movable guards are interlocked		N/A

	The interlocking devices prevent the start of hazardous appliance functions until the guards are fixed in their position, and give a stop command whenever they are no longer closed		N/A
	Where it is possible for an operator to reach the danger zone before the risk due to hazardous appliance functions has ceased, movable guards associated with a guard locking device in addition to an interlocking device that:		--
	- prevents the start of hazardous appliance functions until the guard is closed and locked, and		N/A
	- keeps the guard closed and locked until the risk of injury from the hazardous appliance functions has ceased		N/A
	Interlocking movable guards remain attached to the appliance when open, and		N/A
	they are designed and constructed in such a way that they can be adjusted only by means of an intentional action		N/A
22.ZE.6	Interlocking movable guards designed in such a way that the absence or failure of one of their components prevents starting or stops the hazardous appliance functions		N/A
	The guard is opened to the extent needed to cause the interlocking to operate and is then closed, the number of operations being defined in the specific part 2 :		N/A
	After this test any defect that may be expected in normal use is applied to the interlock system, including interruption of the supply, only one defect being simulated at a time		N/A
	After these tests the interlock system is fit for further use		N/A
22.ZE.7	Adjustable guards restricting access to areas of the moving parts strictly necessary for the work are:		--
	- adjustable manually or automatically, depending on the type of work involved, and		N/A
	- readily adjustable without the use of tools		N/A
22.ZE.8	In case of interruption, re-establishment after an interruption or fluctuation in whatever manner of the power supply, the appliance does not restart		N/A
	However, automatic restarting of the operation is allowed if the appliance may continue to operate, without causing any hazard to the user, from the same point in its operating cycle at which the voltage interruption or fluctuation occurred		N/A
22.ZE.9	Appliances fitted with means to isolate them from all energy sources		N/A
	Such isolators are clearly identified, and		N/A

	they are capable of being locked if reconnection endanger persons		N/A
	After the energy source is disconnected, it is possible to dissipate any energy remaining or stored in the circuits of the appliance without risk to persons		N/A
ZF	ANNEX ZF (INFORMATIVE) CRITERIA APPLIED FOR THE ALLOCATION OF PRODUCTS COVERED BY STANDARDS IN THE EN 60335 SERIES UNDER LVD OR MD		--
	List of standards under CENELEC/TC61 with the allocation under the LVD (Low Voltage Directive) or the MD (Machinery Directive)..... :		P
ZG	ANNEX ZG (NORMATIVE) UV APPLIANCES		--
	The following modifications to this standard apply to appliances having UV emitters		N/A
	This annex is not applicable to appliances covered by the scopes of IEC 60335-2-27, IEC 60335-2-59 or IEC 60335-2-109		N/A
7.12.ZG	The instructions for appliances incorporating UVC emitters include the substance of the following: WARNING — This appliance contains a UV emitter. Do not stare at the light source		N/A
32	For appliances incorporating UV emitters the manufacturer delivers a declaration providing evidence that the plastic material exposed to the radiation is UV resistant		N/A
ZZA	ANNEX ZZA (INFORMATIVE) RELATIONSHIP BETWEEN THIS EUROPEAN STANDARD AND THE SAFETY OBJECTIVES OF DIRECTIVE 2014/35/EU [2014 OJ L96] AIMED TO BE COVERED		--
	Description relating to harmonized standards in the field of the Low Voltage Directive, M/511, to provide one voluntary means of conforming to safety objectives of Directive 2014/35/EU of the European Parliament and of the Council of 26 February 2014 on the harmonization of the laws of the Member States relating to the making available on the market of electrical equipment designed for use within certain voltage limits [2014 OJ L96]		P
	A table with correspondence between this European standard and Annex I of Directive 2014/35/EU [2014 OJ L96]		P

ZZB	ANNEX ZZB (INFORMATIVE) REALATIONSHIP BETWEEN THIS EUROPEAN STANDARD AND THE ESSENTIAL REQUIREMENTS OF DIRECTIVE 2006/42/EC AIMED TO BE COVERED		--
	Description relating to Mandate for standardisation in the field of machinery "M/396" to provide one voluntary means of conforming to essential requirements of EU Directive 2006/42/EC		N/A
	A table with correspondence between this European standard and Annex I of Directive 2006/42/E [OJ No L 157]		N/A
EMF	ANNEX EN 60233 ELECTROMAGNETICS FIELDS		--
	The tested product also complies with the requirements of EN 62233:2008		--
	Limit100 %	Measured max. : ...1,119...%	P

11.Z101	TABLE Z101: Heating test, maximum temperature rises of external enclosures		P
	Test voltage (V)	240 V	—
	Ambient (°C).....	1) 18,0 / 17,0 2) 24,4 / 24,6	—
Surface ^d	Max. temperature rise measured, ΔT (K)		Max. temperature rise limit, ΔT ^{a,b} (K)
	1) RC03-Y	2) RC06B-AY3	
Coated metal	40,7	29,8	55
Plastic	16,8	22,6	65

Supplementary information:

^a In addition to surfaces described under 11.Z101 the following surfaces or elements shall not be taken into consideration:

- hot functional surface: surface which is intentionally heated by an internal heat source and which has to be hot to carry out the function for which the equipment is intended to be used;
- vessels that contain hot liquids and that become hot through conduction by a heated part of the appliance (e.g. coffee pots in percolator type coffee makers and kettles);
- handles or control knobs including keypads, keyboards and the like;
- surfaces of heated cavities or surfaces adjacent to the functional areas inside the compartment.

^b When, due to the construction or dimensional limitations of the appliance, the required values cannot be met, the maximum temperature rise shall not be higher than twice the values indicated. In such cases, a warning shall be marked on the appliance.

^c The temperature rise limit of plastic also applies for plastic material having a metal finish of thickness less than 0,1 mm.

^d When the thickness of the plastic coating does not exceed 0,3 mm, the temperature rise limits of the coated metal or of glass and ceramic material apply.

^e Metal is considered coated when a coating having a minimum thickness of 80 μm made by enamel or non substantially plastic coating is used.

11.Z101	TABLE Z101: Heating test, maximum temperature rises of external enclosures		P
	Test voltage (V) :	240 V	—
	Ambient (°C)..... :	3) 24,0 / 22,1 4) 18,7 / 15,3	—
Surface ^d	Max. temperature rise measured, ΔT (K)		Max. temperature rise limit, ΔT ^{a,b} (K)
	3) RC28A-GY1	4) RC120A-AY2	
Coated metal	44,2	45,5	55
Plastic	14,7	29,1	65

Supplementary information:

- ^a In addition to surfaces described under 11.Z101 the following surfaces or elements shall not be taken into consideration:
- hot functional surface: surface which is intentionally heated by an internal heat source and which has to be hot to carry out the function for which the equipment is intended to be used;
 - vessels that contain hot liquids and that become hot through conduction by a heated part of the appliance (e.g. coffee pots in percolator type coffee makers and kettles);
 - handles or control knobs including keypads, keyboards and the like;
 - surfaces of heated cavities or surfaces adjacent to the functional areas inside the compartment.
- ^b When, due to the construction or dimensional limitations of the appliance, the required values cannot be met, the maximum temperature rise shall not be higher than twice the values indicated. In such cases, a warning shall be marked on the appliance.
- ^c The temperature rise limit of plastic also applies for plastic material having a metal finish of thickness less than 0,1 mm.
- ^d When the thickness of the plastic coating does not exceed 0,3 mm, the temperature rise limits of the coated metal or of glass and ceramic material apply.
- ^e Metal is considered coated when a coating having a minimum thickness of 80 μm made by enamel or non substantially plastic coating is used.

11.Z101	TABLE Z101: Heating test, maximum temperature rises of external enclosures		P
	Test voltage (V) :	240 V	—
	Ambient (°C)..... :	5) 23,0 / 22,7 6) 21,4 / 20,7	—
Surface ^d	Max. temperature rise measured, ΔT (K)		Max. temperature rise limit, ΔT ^{a,b} (K)
	5) DRC10S1-GWA3	6) DRC36S-GPA3	
Plastic	37,9	32,7	65
Coated metal	42,5	42,0	55
<p>Supplementary information:</p> <p>^a In addition to surfaces described under 11.Z101 the following surfaces or elements shall not be taken into consideration:</p> <ul style="list-style-type: none"> • hot functional surface: surface which is intentionally heated by an internal heat source and which has to be hot to carry out the function for which the equipment is intended to be used; • vessels that contain hot liquids and that become hot through conduction by a heated part of the appliance (e.g. coffee pots in percolator type coffee makers and kettles); • handles or control knobs including keypads, keyboards and the like; • surfaces of heated cavities or surfaces adjacent to the functional areas inside the compartment. <p>^b When, due to the construction or dimensional limitations of the appliance, the required values cannot be met, the maximum temperature rise shall not be higher than twice the values indicated. In such cases, a warning shall be marked on the appliance.</p> <p>^c The temperature rise limit of plastic also applies for plastic material having a metal finish of thickness less than 0,1 mm.</p> <p>^d When the thickness of the plastic coating does not exceed 0,3 mm, the temperature rise limits of the coated metal or of glass and ceramic material apply.</p> <p>^e Metal is considered coated when a coating having a minimum thickness of 80 μm made by enamel or non substantially plastic coating is used.</p>			

11.Z101	TABLE Z101: Heating test, maximum temperature rises of external enclosures		P
	Test voltage (V) :	240 V	—
	Ambient (°C)..... :	7) 21,6 / 21,4 8) 23,1 / 22,1	—
Surface ^d	Max. temperature rise measured, ΔT (K)		Max. temperature rise limit, ΔT ^{a,b} (K)
	7) SRC06S1-WPY3	8) SRC28S-WPY3	
Coated metal	45,2	51,7	55
Plastic	30,7	26,2	65
<p>Supplementary information:</p> <p>^a In addition to surfaces described under 11.Z101 the following surfaces or elements shall not be taken into consideration:</p> <ul style="list-style-type: none"> • hot functional surface: surface which is intentionally heated by an internal heat source and which has to be hot to carry out the function for which the equipment is intended to be used; • vessels that contain hot liquids and that become hot through conduction by a heated part of the appliance (e.g. coffee pots in percolator type coffee makers and kettles); • handles or control knobs including keypads, keyboards and the like; • surfaces of heated cavities or surfaces adjacent to the functional areas inside the compartment. <p>^b When, due to the construction or dimensional limitations of the appliance, the required values cannot be met, the maximum temperature rise shall not be higher than twice the values indicated. In such cases, a warning shall be marked on the appliance.</p> <p>^c The temperature rise limit of plastic also applies for plastic material having a metal finish of thickness less than 0,1 mm.</p> <p>^d When the thickness of the plastic coating does not exceed 0,3 mm, the temperature rise limits of the coated metal or of glass and ceramic material apply.</p> <p>^e Metal is considered coated when a coating having a minimum thickness of 80 μm made by enamel or non substantially plastic coating is used.</p>			

---End of this attachment ---

Attachment 2

EN 60335-1: 2012 /A13: 2017			
Clause	Requirement - Test	Result - Remark	Verdict

<p>ATTACHMENT TO TEST REPORT EN 60335-1 Household and similar electrical appliances – Safety – Part 1: General requirements</p>	
Differences according to	EN 60335-1: 2012 /A13: 2017
Attachment Form No.	EN 60335_1
Attachment Originator	SGS-CSTC
Master Attachment	Date 2018-01

Annex ZC	Replace Annex ZC of EN 60335-1:2012	P
Replace Annex ZZ of EN 60335-1:2012 with Annex ZZA& ZZB		P
Annex ZZA	(informative) Relationship between this European standard and the safety objectives of Directive 2014/35/EU [2014 OJ L96] aimed to be covered	P
Annex ZZB	(informative) Relationship between this European standard and the essential requirements of Directive 2006/42/EC aimed to be covered	N/A

--- End of this Attachment --

Attachment 3

Circuit diagram

Details of: Model RC03-y (Not for CE and GS)

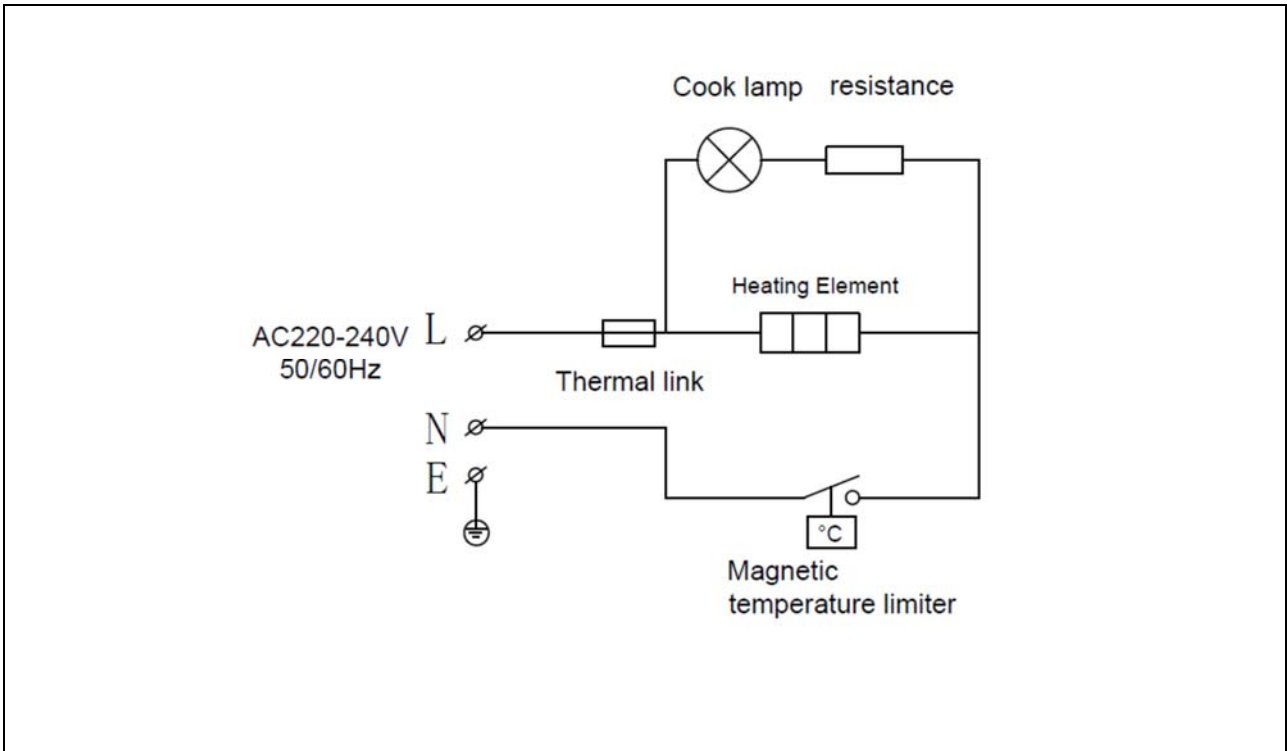

Details of: Model RC03-y (for CE and GS)

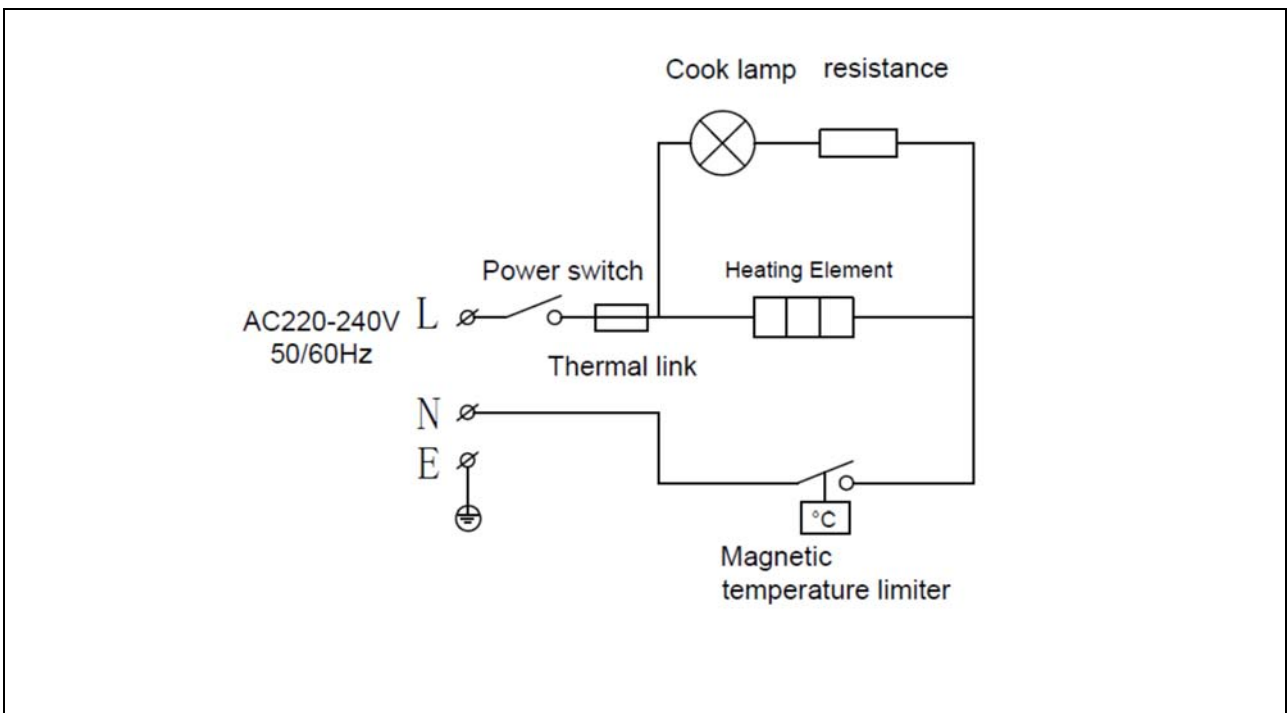

Attachment 3

Details of: For the models z = 1 (Not for CE and GS)

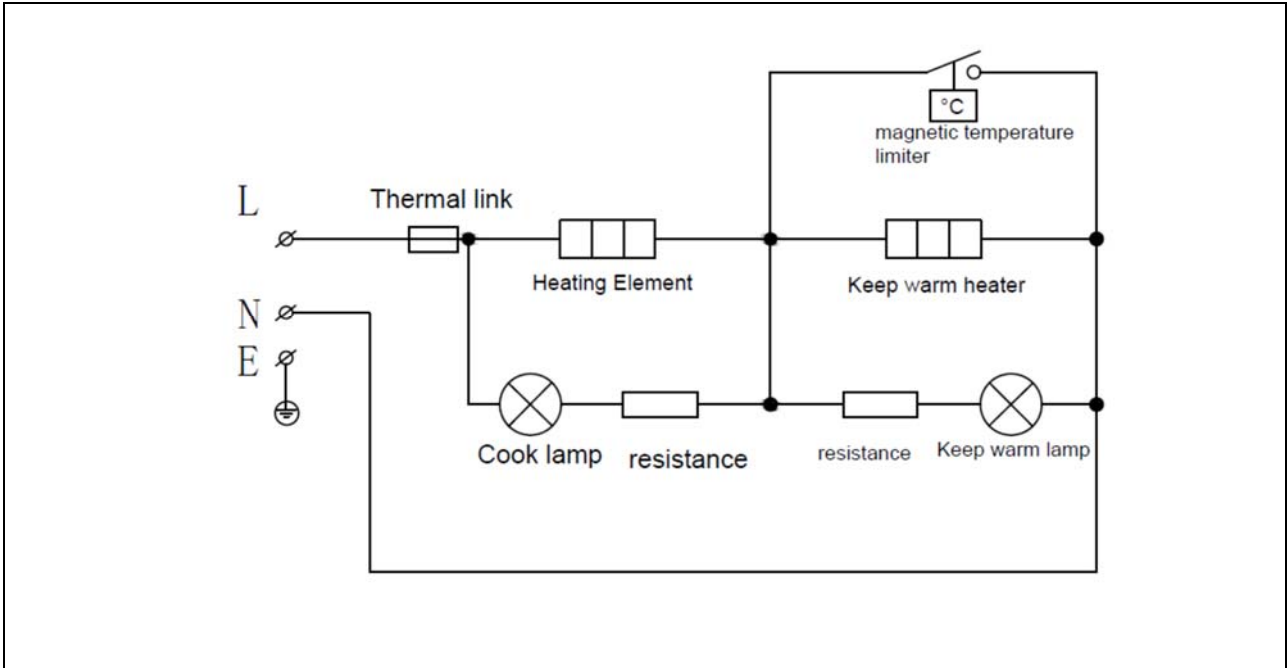

Details of: For the models z = 1 (for CE and GS)

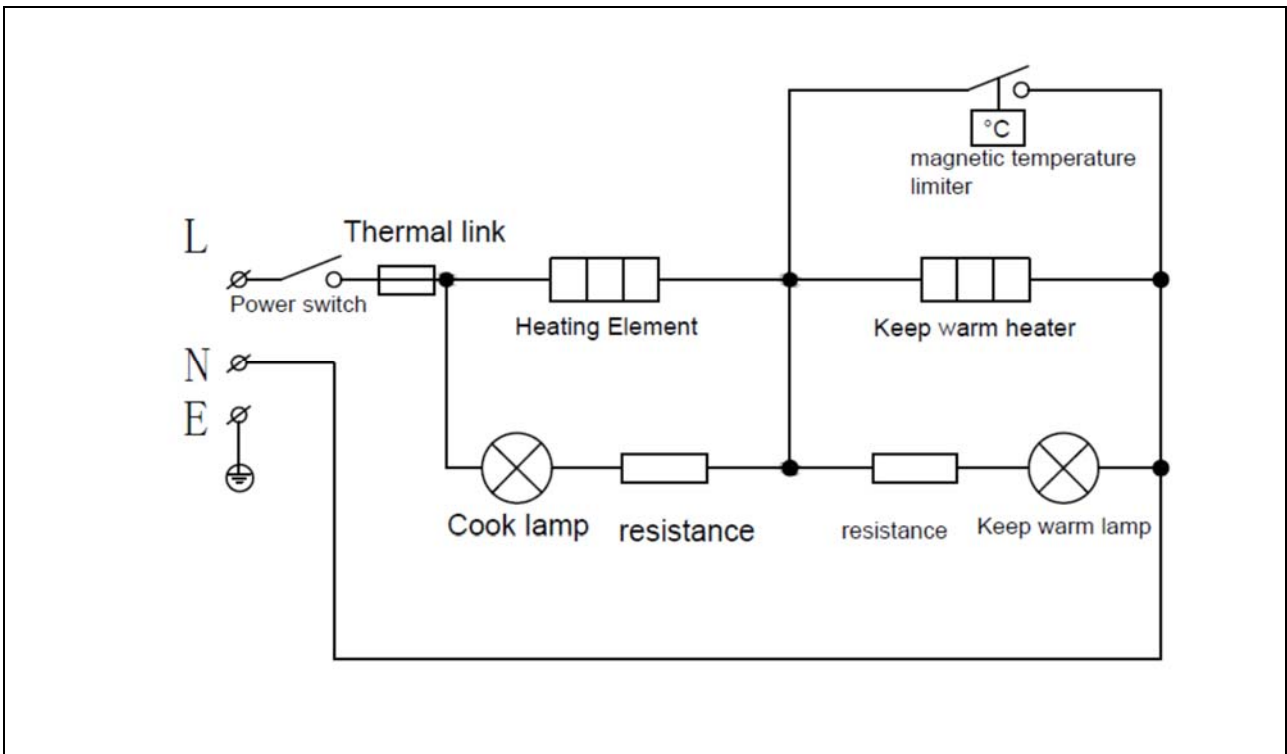

Attachment 3

Details of: For the models z = 2 (Not for CE and GS)

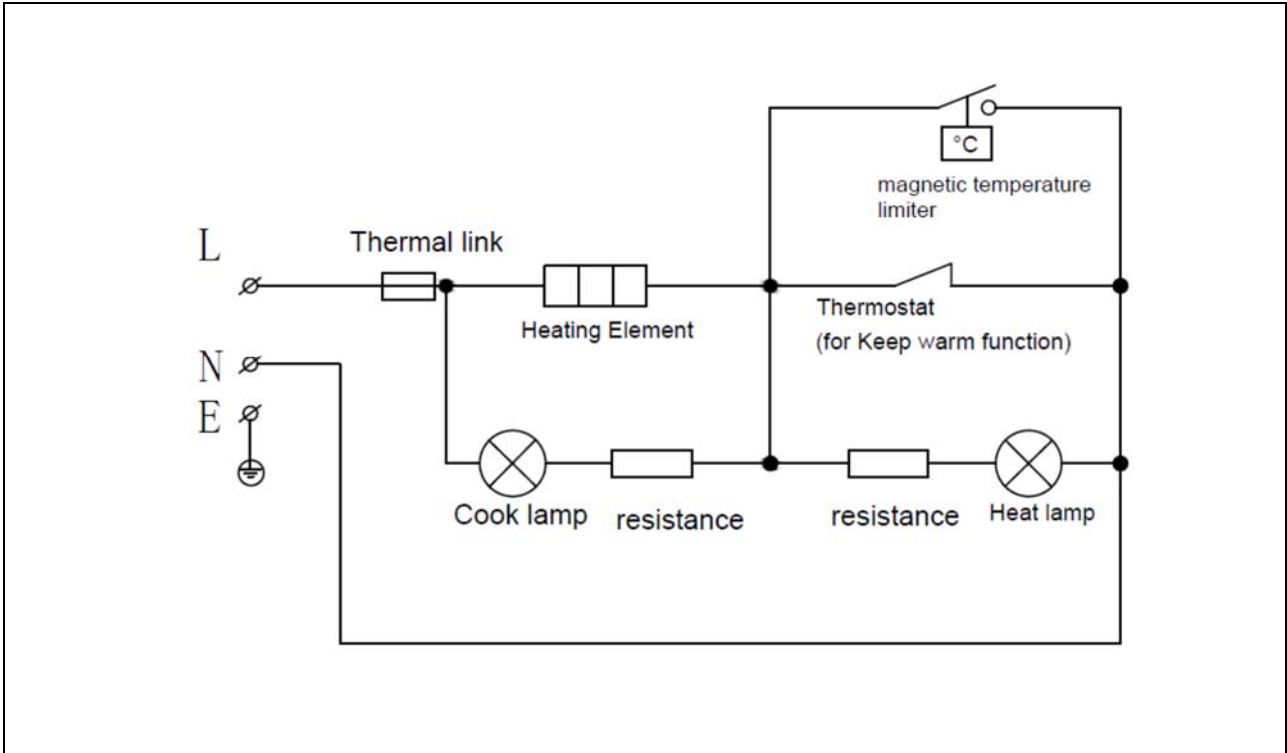

Details of: For the models z = 2 (for CE and GS)

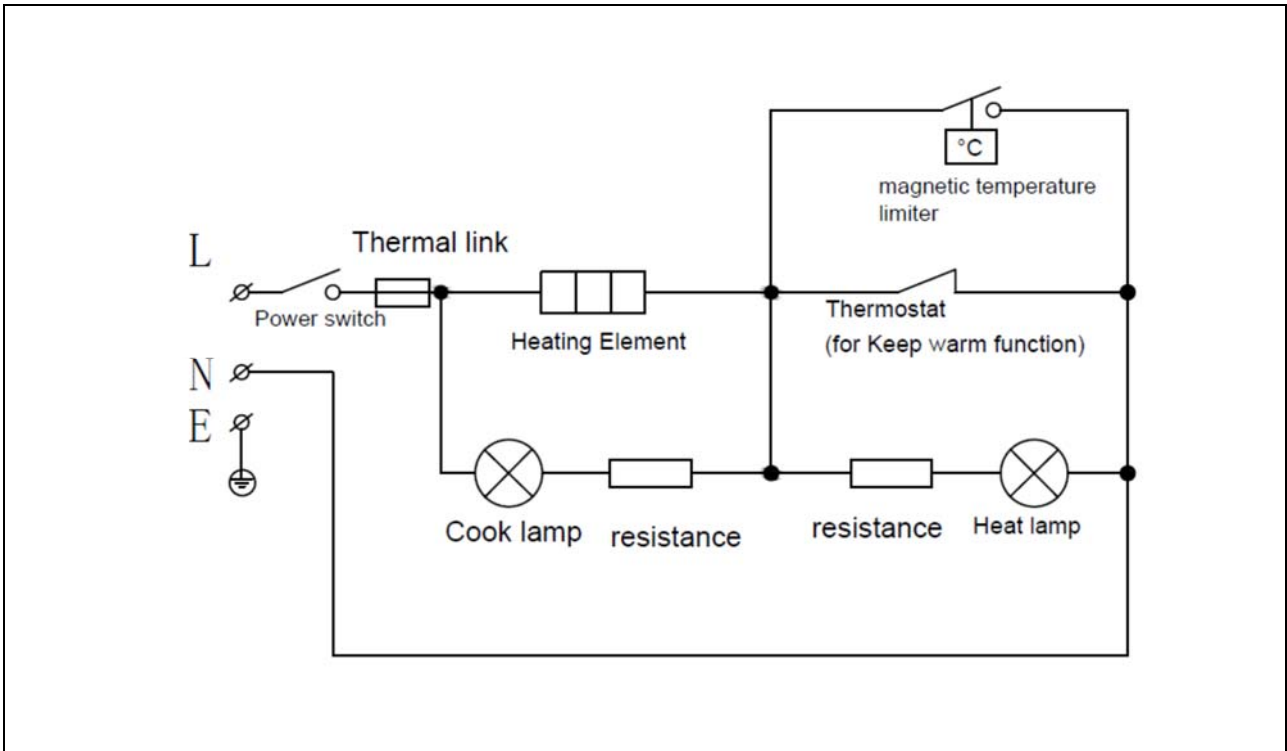

Attachment 3

Details of: For the models z = 3 (Not for CE and GS)

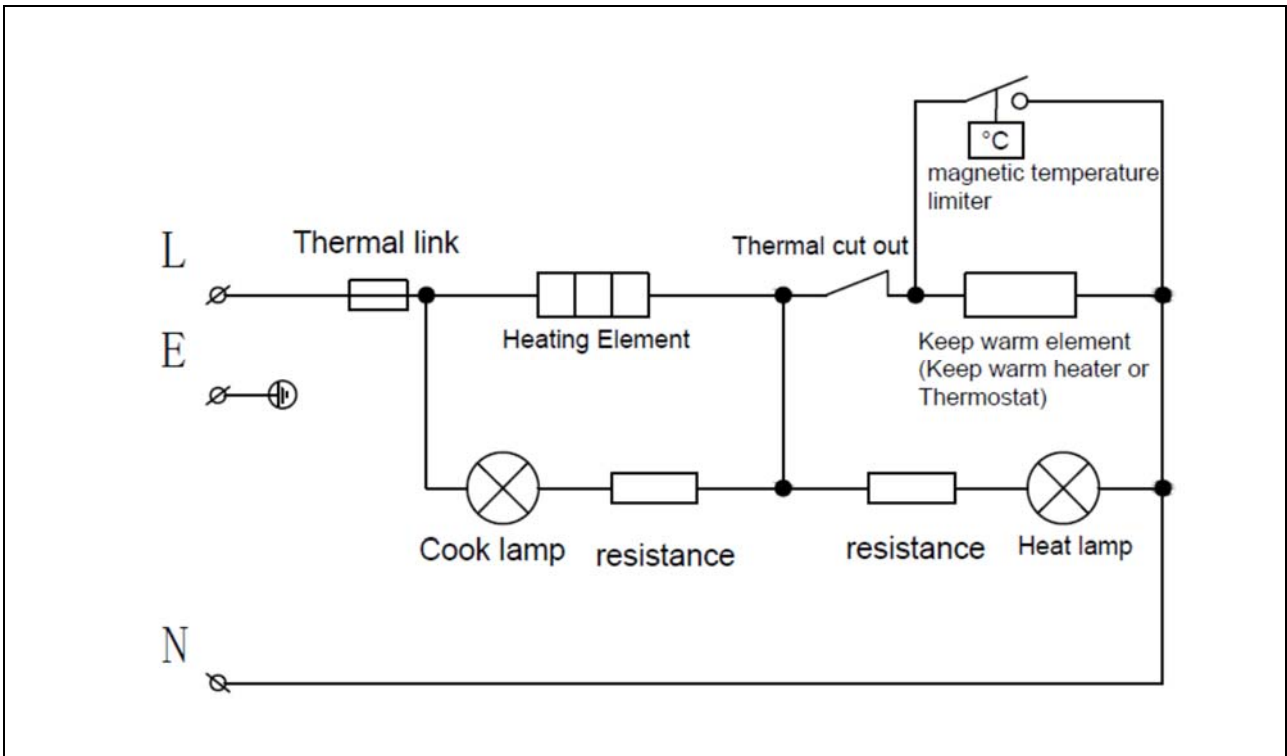

Details of: For the models z = 3 (for CE and GS)

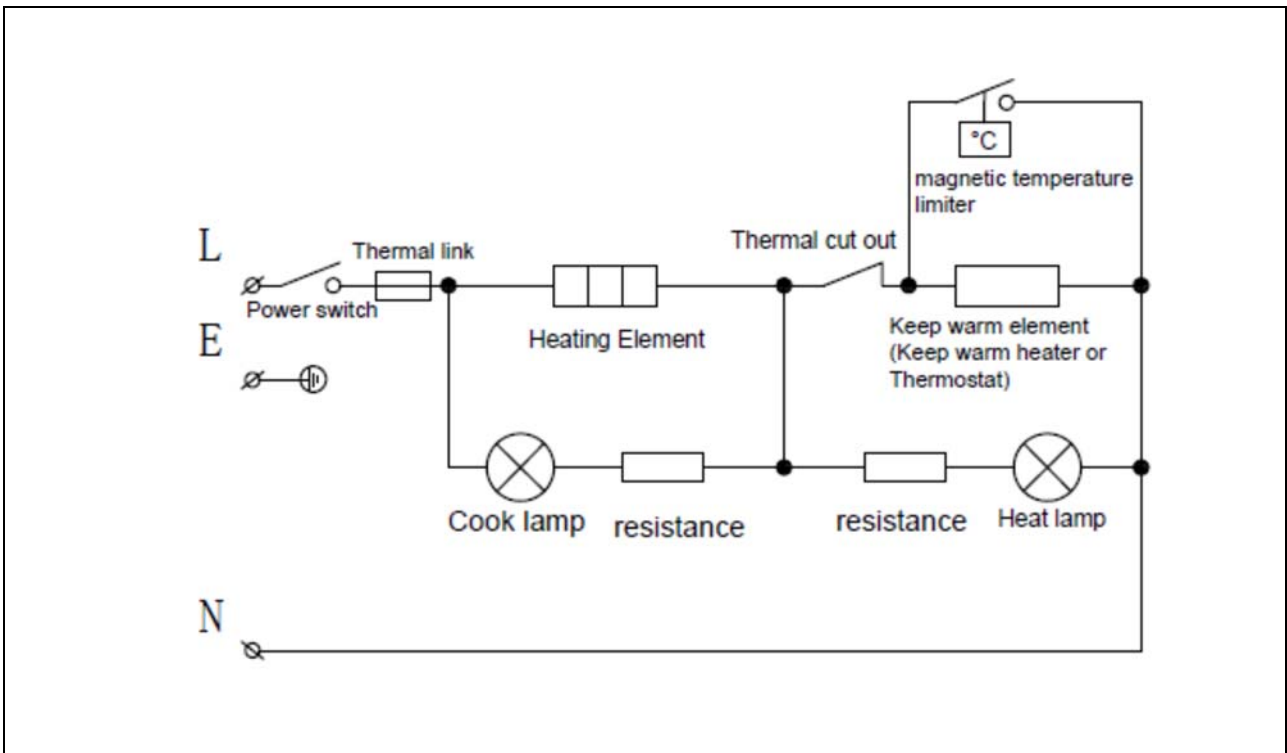

Attachment 4**Photo document**

Type of equipment / model: Rice cooker

Details of: RC03-Y

View:

- general
- front
- rear
- right
- left
- top
- bottom



Details of: RC03-Y

View:

- general
- front
- rear
- right
- left
- top
- bottom



Attachment 4

Details of: RC03-Y

View:

- general
- front
- rear
- right
- left
- top
- bottom



Details of: RC03-Y

View:

- general
- front
- rear
- right
- left
- top
- bottom



Attachment 4Details of: RC03-X

View:

- general
- front
- rear
- right
- left
- top
- bottom

Details of: RC28A-GY1

View:

- general
- front
- rear
- right
- left
- top
- bottom



Attachment 4Details of: RC28A-GY1

View:

- general
- front
- rear
- right
- left
- top
- bottom

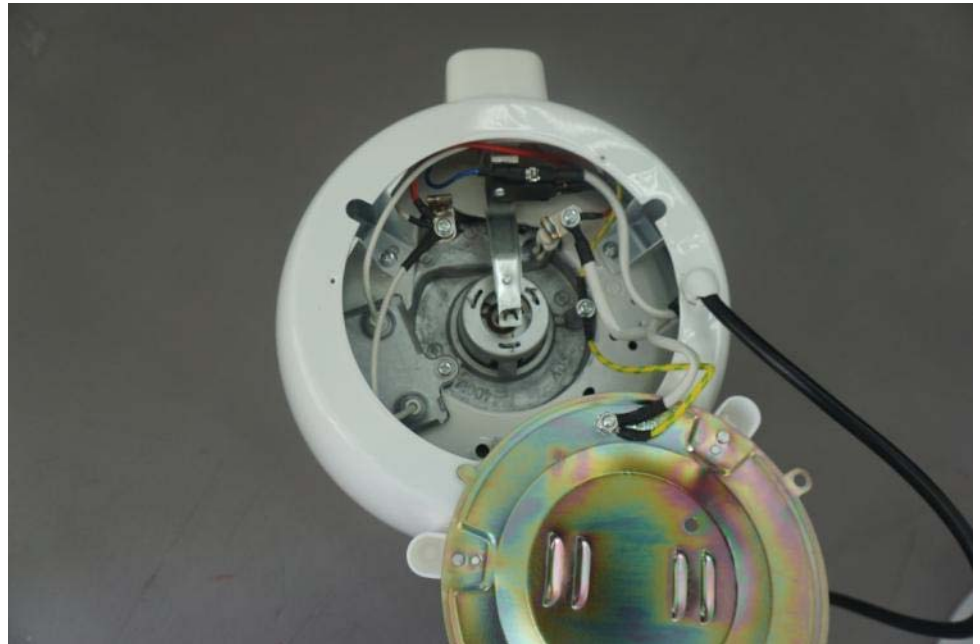
Details of: RC28A-NX3

View:

- general
- front
- rear
- right
- left
- top
- bottom



Attachment 4Details of: RC28A-NX1

View:

- general
- front
- rear
- right
- left
- top
- bottom

Details of: RC120A-AY3

View:

- general
- front
- rear
- right
- left
- top
- bottom



Attachment 4

Details of: RC120A-AY3

View:

- general
- front
- rear
- right
- left
- top
- bottom



Details of: RC10-OY1

View:

- general
- front
- rear
- right
- left
- top
- bottom



Attachment 4

Details of: RC10-OY1

View:

- general
- front
- rear
- right
- left
- top
- bottom

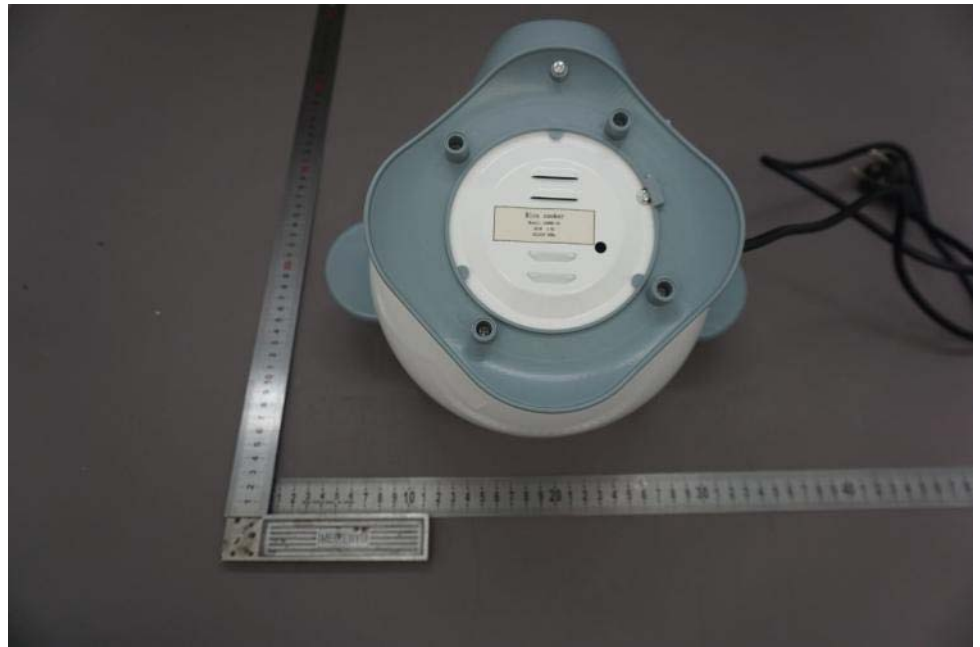

Details of: RC10-OY1

View:

- general
- front
- rear
- right
- left
- top
- bottom

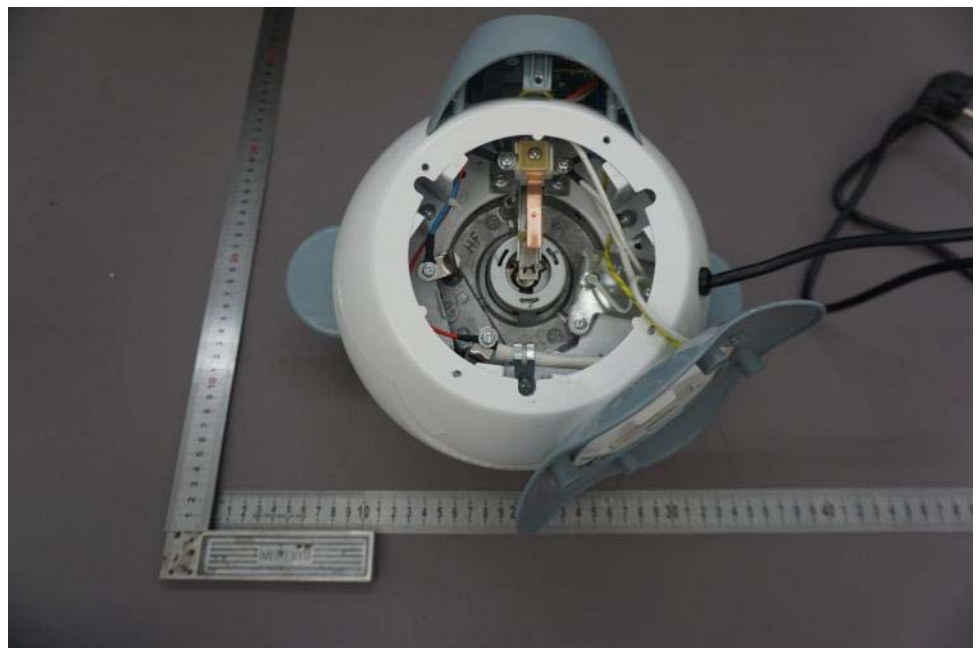

Attachment 4

Details of: RC10A-GY3

View:

- general
- front
- rear
- right
- left
- top
- bottom

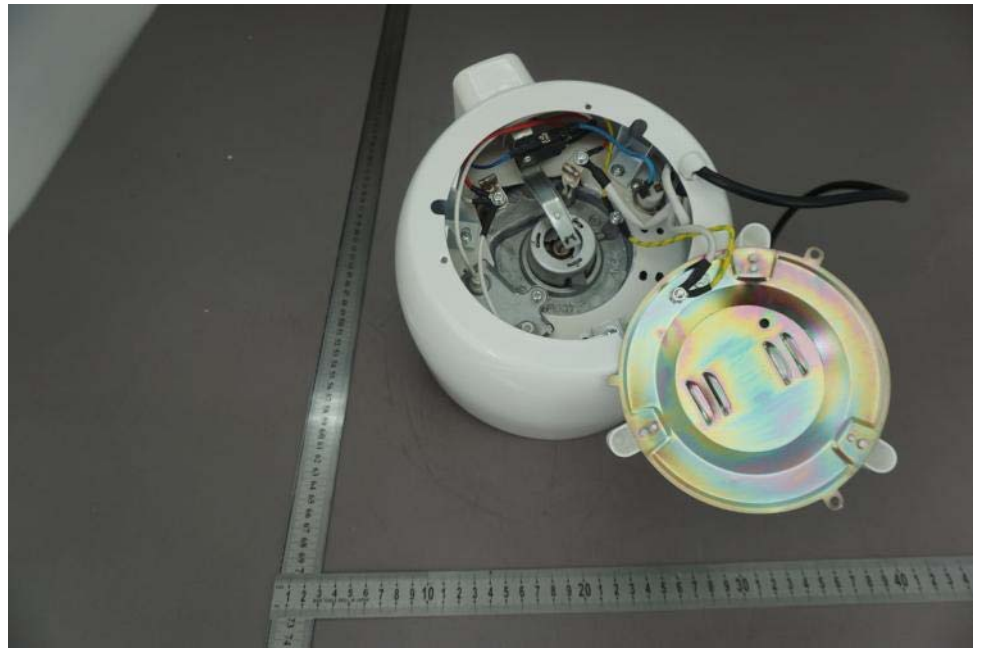

Details of: RC15A-MX2

View:

- general
- front
- rear
- right
- left
- top
- bottom



Attachment 4

Details of: RC18A-LX1

View:

- general
- front
- rear
- right
- left
- top
- bottom



Details of: RC36A-AY2

View:

- general
- front
- rear
- right
- left
- top
- bottom



Attachment 4Details of: RC36A-AY2

View:

- general
- front
- rear
- right
- left
- top
- bottom

Details of: DRC10S-IPE1

View:

- general
- front
- rear
- right
- left
- top
- bottom



Attachment 4

Details of: DRC10S-IPE1

View:

- general
- front
- rear
- right
- left
- top
- bottom



Details of: DRC10S-IPE1

View:

- general
- front
- rear
- right
- left
- top
- bottom



Attachment 4Details of: DRC10S-IPE1

View:

- general
- front
- rear
- right
- left
- top
- bottom

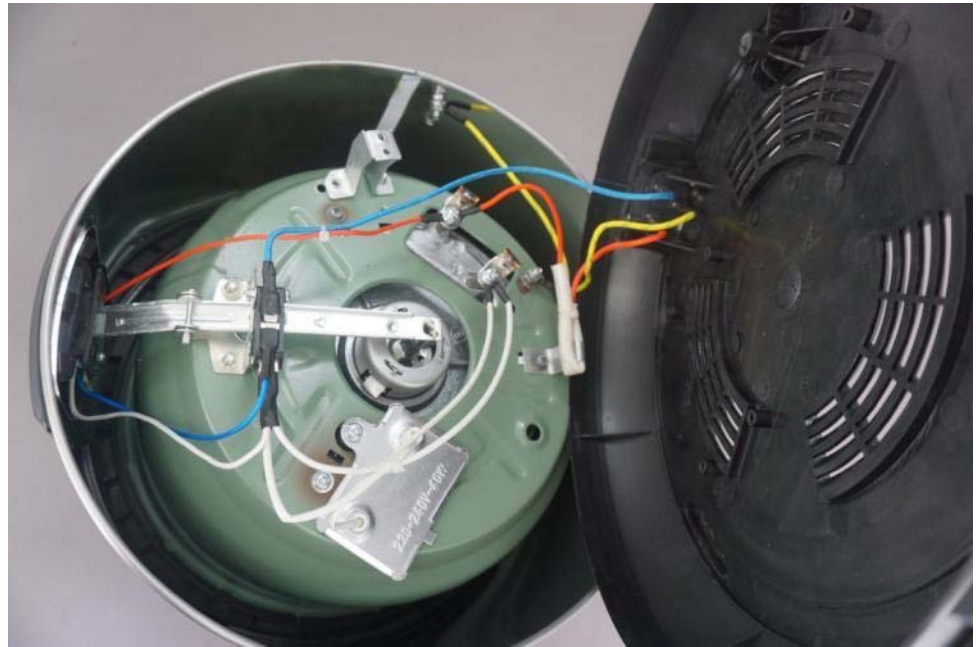
Details of: DRC36C1-xWB2

View:

- general
- front
- rear
- right
- left
- top
- bottom



Attachment 4

Details of: DRC36S1-xPB3

View:

- general
- front
- rear
- right
- left
- top
- bottom



Details of: DRC15C-xWB1

View:

- general
- front
- rear
- right
- left
- top
- bottom

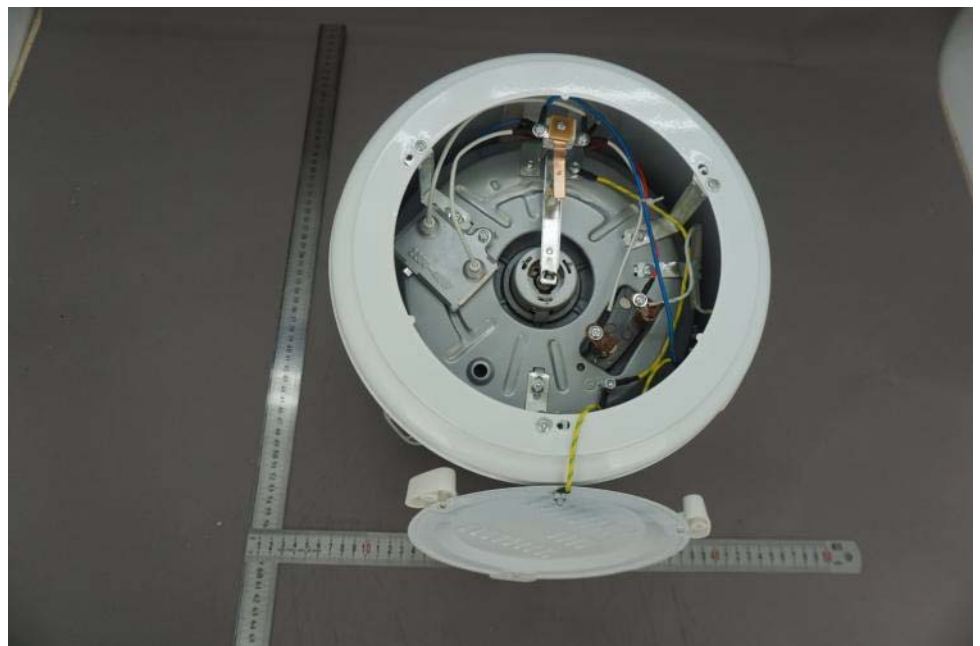

Attachment 4

Details of: DRC18S-aVA1

View:

- general
- front
- rear
- right
- left
- top
- bottom



Details of: DRC22C-iPO1

View:

- general
- front
- rear
- right
- left
- top
- bottom

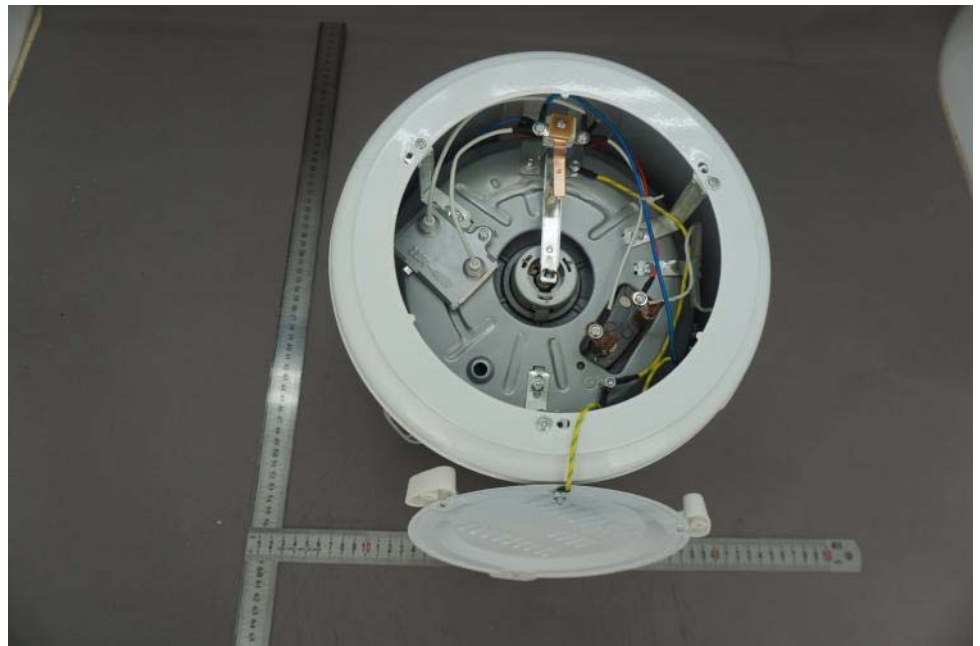

Attachment 4Details of: SRC06C-qPY1

View:

- general
- front
- rear
- right
- left
- top
- bottom

Details of: SRC06C-qPY1

View:

- general
- front
- rear
- right
- left
- top
- bottom



Attachment 4

Details of: SRC06C-mPX1

View:

- general
- front
- rear
- right
- left
- top
- bottom

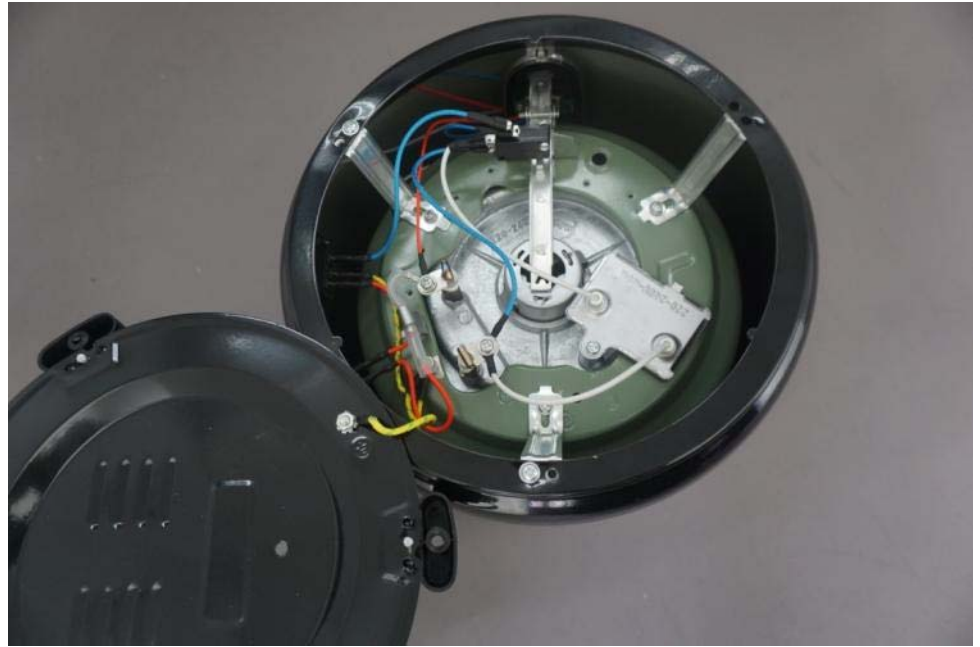

Details of: SRC28C-rWX3

View:

- general
- front
- rear
- right
- left
- top
- bottom



Attachment 4Details of: SRC28C-rWX3

View:

- general
- front
- rear
- right
- left
- top
- bottom

Details of: SRC15C-rWX1

View:

- general
- front
- rear
- right
- left
- top
- bottom

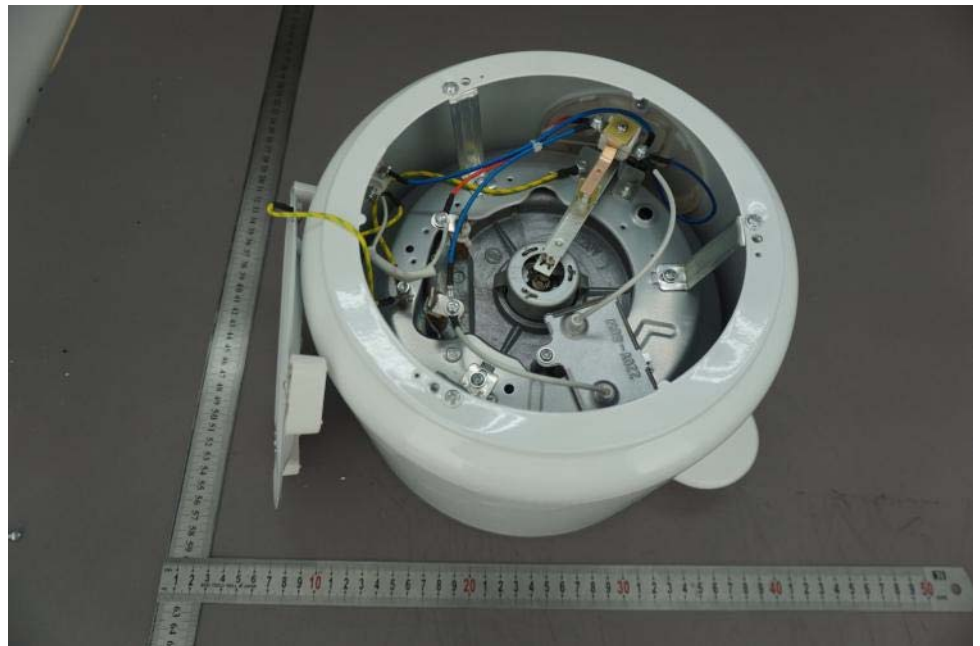

Attachment 4

Details of: SRC18C1-wVX3

View:

- general
- front
- rear
- right
- left
- top
- bottom



Details of: SRC18C1-wVY3

View:

- general
- front
- rear
- right
- left
- top
- bottom

